

7leaders®
The Art of Cutting



SOLID CARBIDE

End Mills | Drills | Reamers

COMPANY PROFILE



7-Leaders Corp. specializes in production and marketing of tungsten carbide cutting tools such as End mills, Drills, Reamers, and etc.

Established in 1990 by Mr. Jack Lee, the company manufactures high quality products and provides best services along with the trade mark "7leaders" all over the world. 7Leaders manufactures solid carbide cutting tools for Mold& Die, Machine Tools, Automotive, Aerospace, 3C, Watches, Optical and Medical solutions.



Our products have been distributed in the Europe, Asia, Central America, Brazil and other nations.

We keep integrating marketing in all kinds of cutting tools and providing the best quality products to our customers. We aim to become a leading brand name in the cutting tools industry.

PRODUCTION PROCESS

24 Hours a Day. 365 Days
a Year Automated
Production Capabilities

Tungsten
Carbide Rods



7-Leaders cooperates with a world-renowned tungsten carbide rod manufacturer, producing high quality tungsten carbide rods in ETM brand.

Tools
Manufacturing



7-Leaders has Walter and Rollomatic CNC grinding machines and manufactures end mills, drills and reamers.

Coating Service

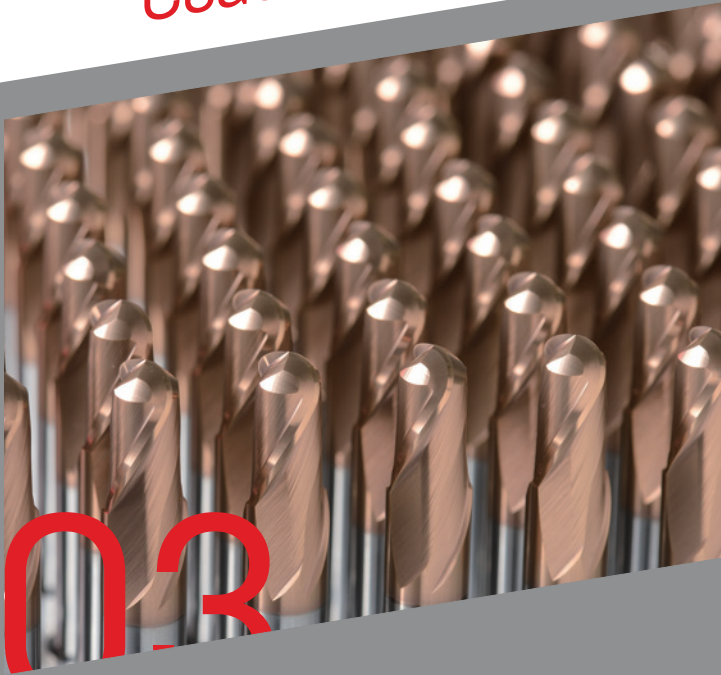

03

Our Nano thin film coating center uses cathodic arc evaporation splitting coating machines from "PVD" in Switzerland. 7-Leaders is the first company applying "splitting arc" technology in Taiwan. We provide variable coating service.

Application

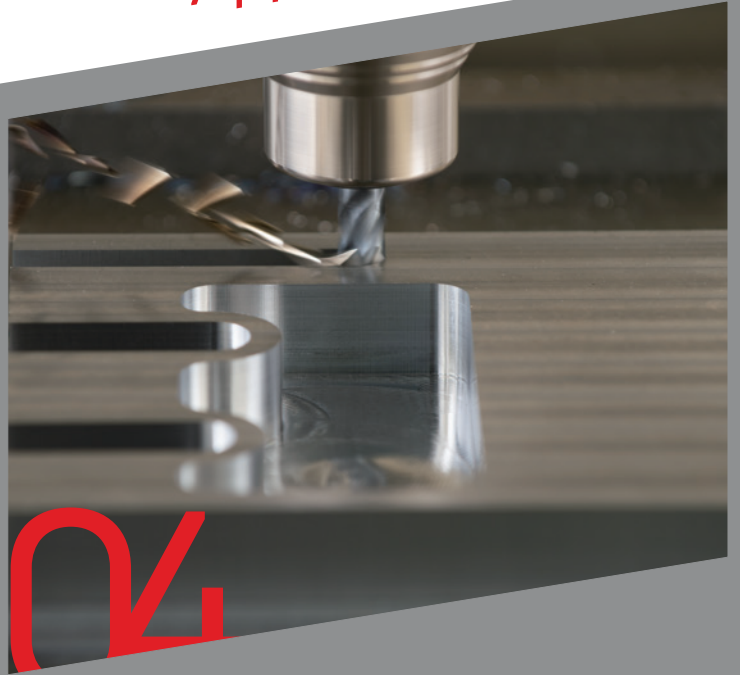

04

7-Leaders manufactures cutting tools through strict cutting test and fulfill customers' requirements on application.

Outstanding Anti-Vibration

Under High Speed Machining

Unequal Flutes, Variable Helix Geometry



Big Capacity Slot

Achieve high efficiency of chip removal

High Rigidity

Secure working stability

Sharp Cutting Flute

Efficiently reduce cutting force

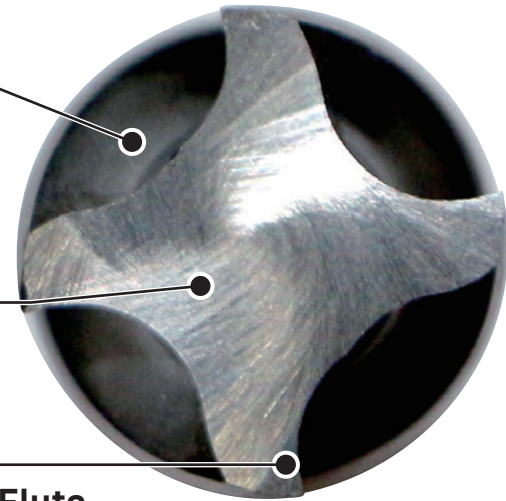

HIGH Performance

Efficient Chip Removal

Tool	E140HX ϕ 12
Work Piece	S50C (about 20HRC)
Milling Method	Slotting
RPM	3180 rev/min
Cutting Speed	120 m/min
Feed	900 mm/min
Feed	0.07 mm/tooth
Milling Depth	Ap: 24 mm Ae: 12 mm
Coolant	air cooling

Cutting Chips



2XD Slotting



Unequal flutes and variable helix can greatly suppress vibration.

Additionally, special design of chip slot perfectly increases the capacity for chip removal and achieve stable slotting machining.

HIGH Wear Resistance

Longer Cutting Life Time

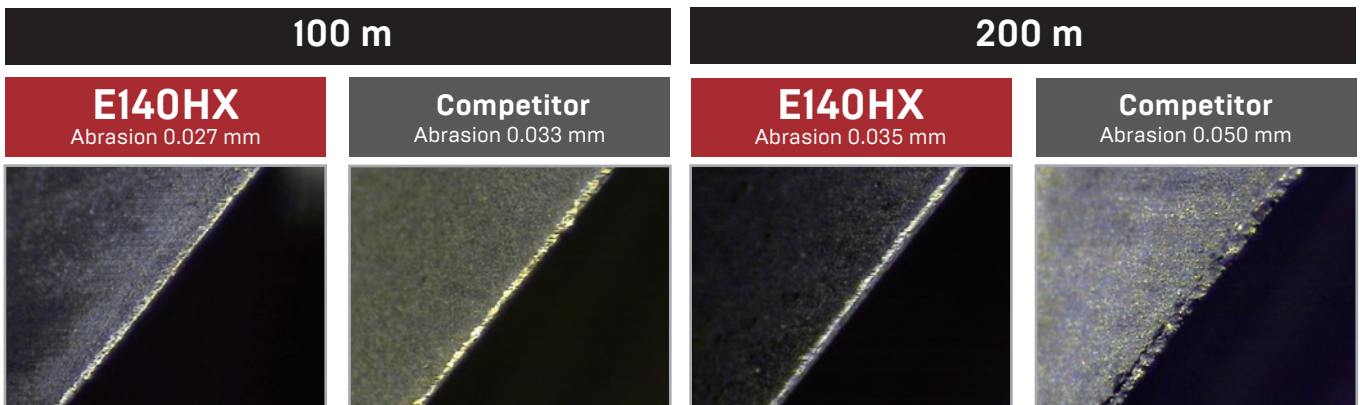
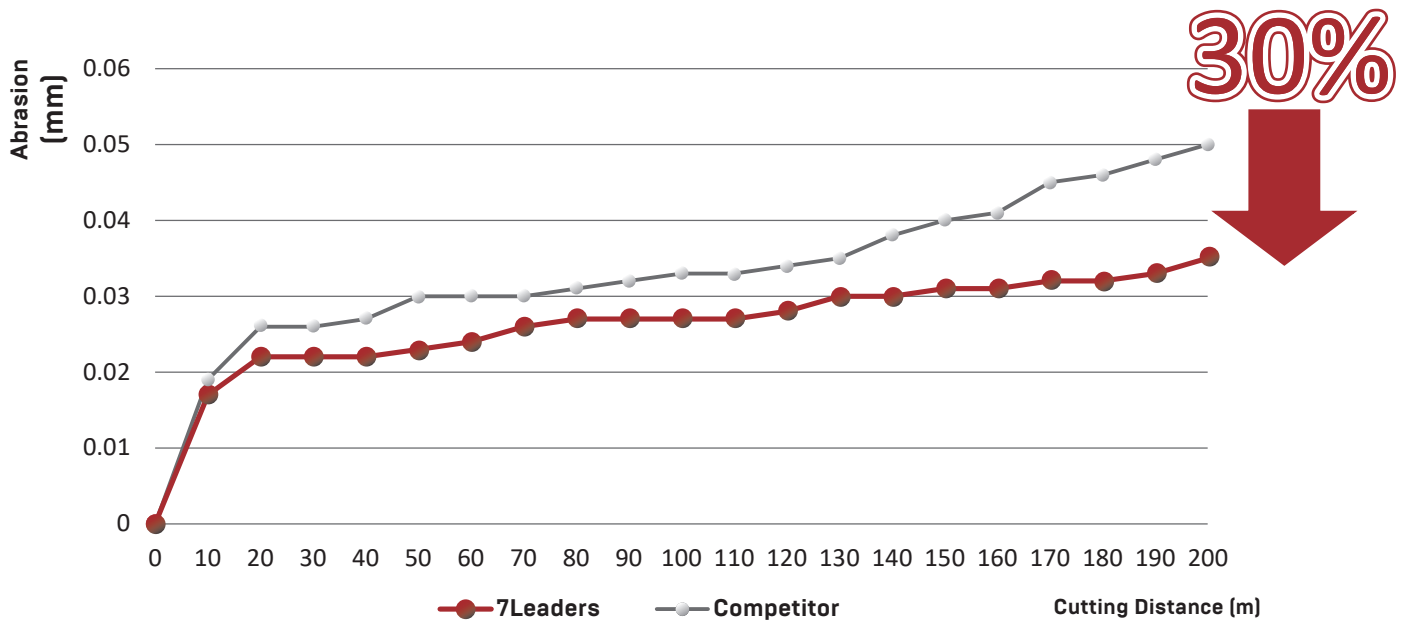

Tool	E140HX ϕ 10
Work Piece	S50C (about 20HRC)
Milling Method	Side Milling
RPM	3650 rev/min
Cutting Speed	114 m/min
Feed	770 mm/min
Feed	0.052 mm/tooth
Milling Depth	Ap: 20 mm Ae: 1 mm
Coolant	air cooling

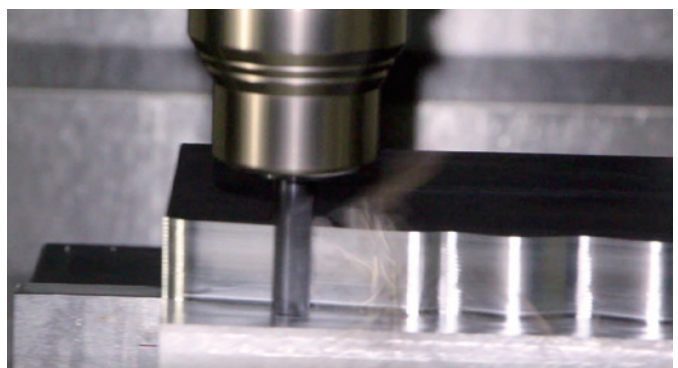

With the same test condition, the abrasion rate of E140HX from 7Leaders is 30% lower than the competitor brand.

By comparing the pictures of the cutting edge, E140HX reliably shows excellent wear resistance.

Superior Ball R Precision Within 5 μm

Excellent Heat & Wear Resistance

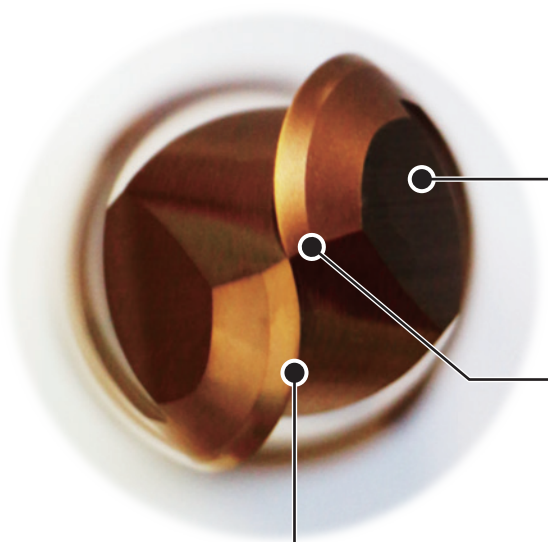

Bigger Corner Radius

Lower cutting resistance

Corner Radius With High Thickness

Stronger edge rigidity

Small Edge Cutting Land

Stronger cutting edge, higher surface smoothness

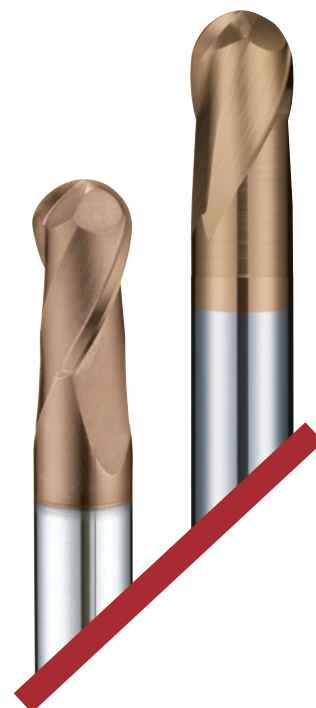

Tool	B272ATX $\phi 6$
Work Piece	SKD11 (about 62HRC)
Milling Method	Profile Copying
RPM	9000 rev/min
Cutting Speed	170 m/min
Feed	2500 mm/min
Feed	0.138 mm/tooth
Milling Depth	Ap: 0.05 mm Ae: 0.1 mm
Coolant	air cooling

3D Surface Finishing

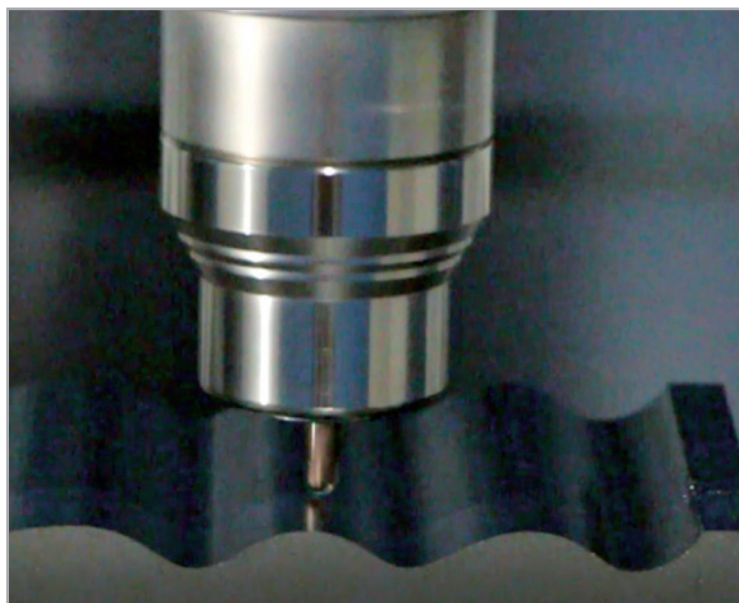

HIGH Wear Resistance

Longer Cutting Life Time

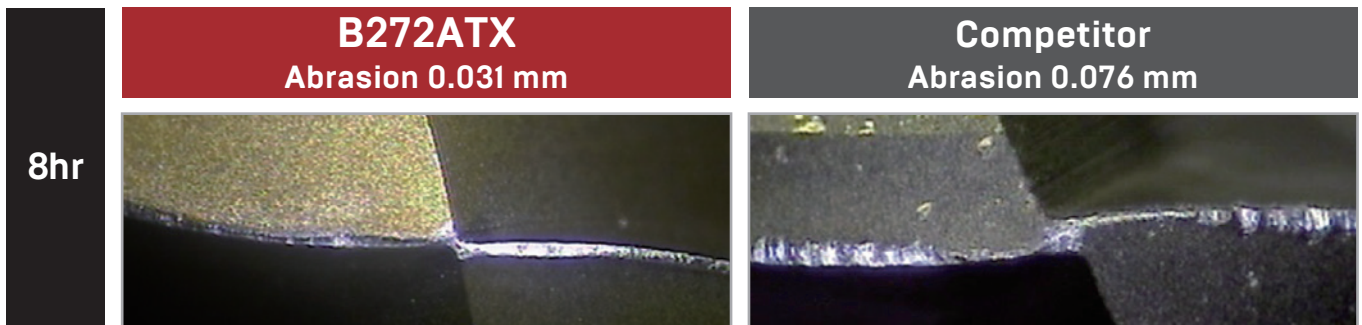
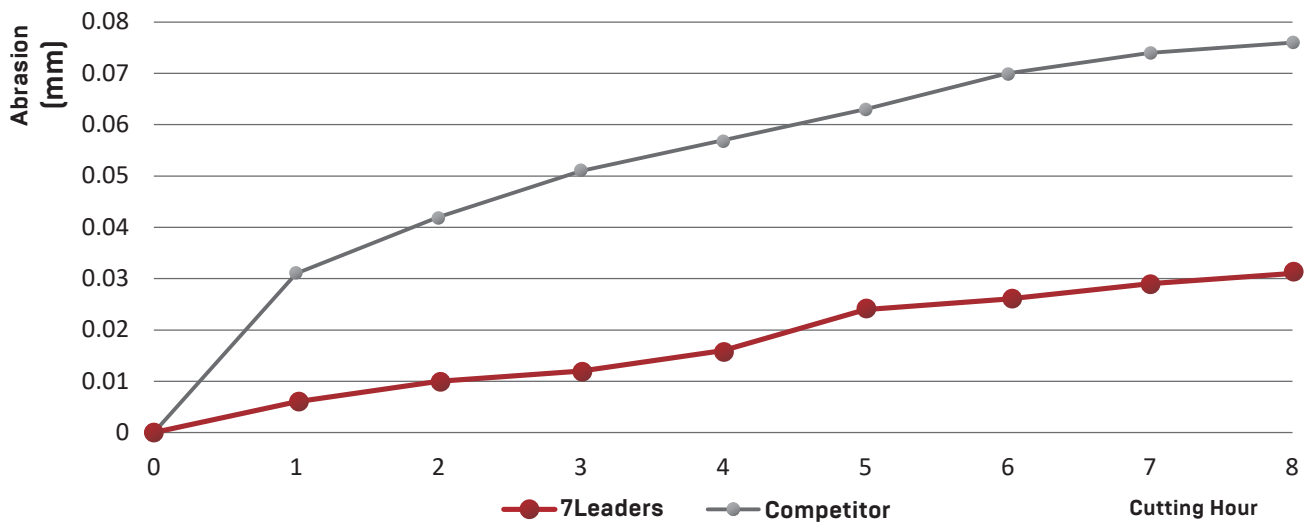

EXCELLENT Surface Smoothness

Finishing Surface Smoothness

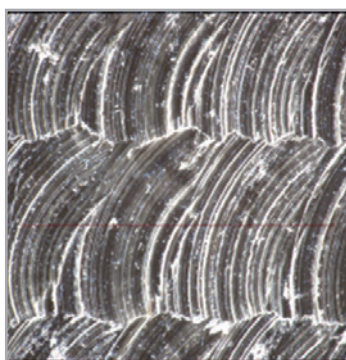

Surface Roughness Curve (Ra 0.36 μm)

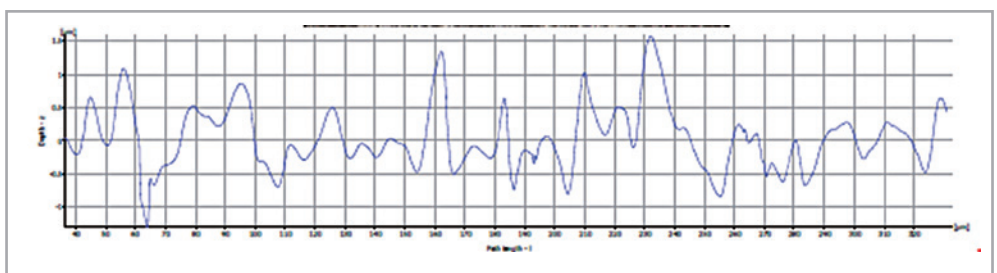

Under the same test condition, the tool life of B272ATX is nearly 50% longer than competitor brand and remain keeps excellent wear resistance in HSC performance.

Meanwhile, the cost of tools for machining high hardness materials are efficiently lower.



Guide Lines

Tool Material

- MG Carbide** Micro Grain
- UMG Carbide** Ultra Micro Grain
- SMG Carbide** Super Micro Grain

Number of Flute



Helix Angle

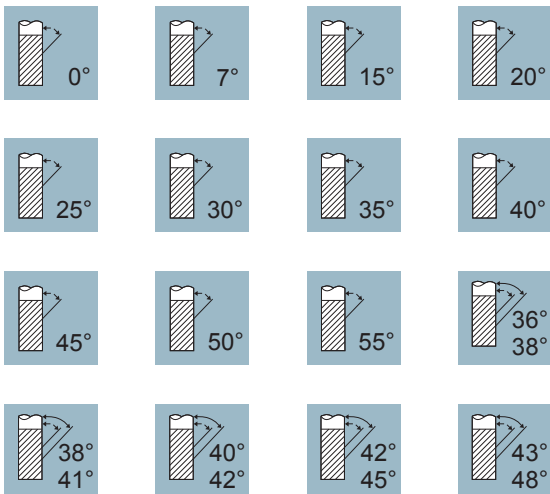

Coating Type

- TiAlN F-NaNo** High heat resistance, high oxidation resistance, nanocomposite coating with lubrication property. Suitable for any material and steels < 48HRC.
- AlTiN X-NaNo** Very high heat resistance and oxidation resistance. Suitable for steels < 52HRC.
- AlTiCrN HX** Multilayer, higher hardness, high oxidation resistance. Suitable for steels < 48 HRC.
- AlTiXN X1** Multilayer, higher nanohardness, extremely high heat resistance, very good thermal insulation. Suitable for high performance machining condition and also for midhardness alloy steels to 62HRC.
- AlTiSiN TX** Multilayer, higher nanohardness, extremely high heat resistance, very good thermal insulation. Suitable for high performance machining condition and also for midhardness alloy steels to 70HRC.
- AlTiXN+ZrN SX** The cutting tools that are coated with multilayer nano film have some advantages as follow: AlTiZrN with extremely high heat and oxidation resistance, as well as good toughness and a smooth surface qualify. These benefits substantially enhance the tool life.
- ZrN ZX** Coating features: High surface finish with strong wear resistance, anti-oxidation, low friction, anti-adhesion. Application: Suitable for machining difficult material like aluminum, copper, stainless steels, titanium.
- DLC DX** The cutting tools that are coated with multilayer nanorainbow film have some advantages as follow: Abrasion resistance, low-coefficient of friction, Anti-adhesion. These benefits substantially enhance the tool life.
- Diamond Dc** Extremely high hardness, good chemical stability. Suitable for machining graphite.

Relief

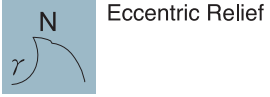

Corner of Edges

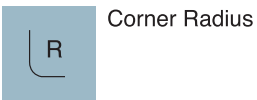
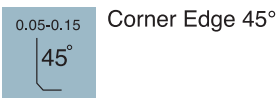
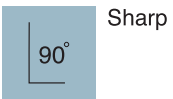







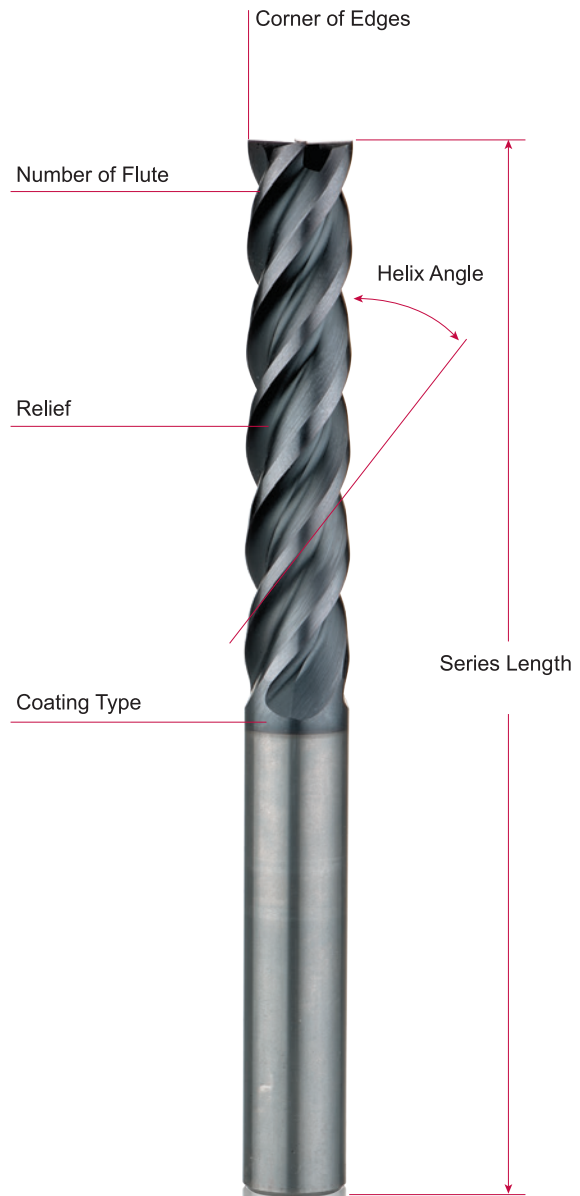
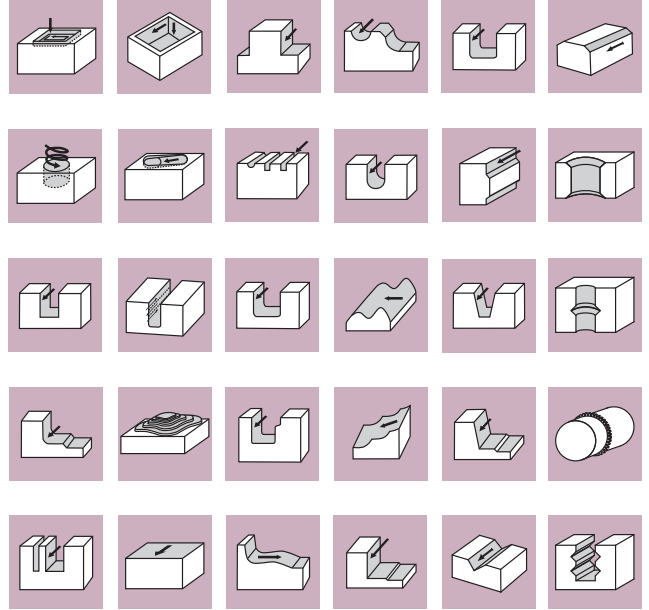















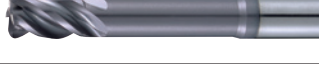





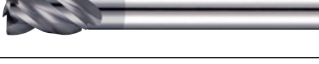





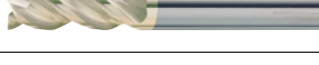







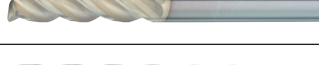





































Series Length













































































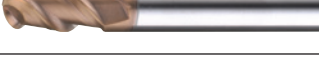





Type of Operation







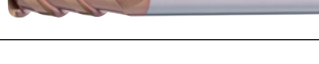































































Series	Code No.	Appearance	Flute	Product Name	Page
Multipurpose End Mills	E130HX			Multipurpose End Mills	3
	E140HX			Multipurpose End Mills	5
	E141-1.5HX E141-2.0HX E141-3.0HX			Multipurpose End Mills	7
	E141-4.0HX E141-5.0HX			Multipurpose End Mills	9
	E144X			Multipurpose End Mills	11
	E144-4.0X E144-5.0X E144-6.0X			Multipurpose End Mills	13
	B252-2.5HX			Multipurpose End Mills With Corner Radius	15
	B274HX			Multipurpose End Mills With Corner Radius	19
	F612HX F617HX			Multipurpose End Mills	21
	E148HX			Multipurpose End Mills · Slim Shank · Short Type	23
	E149HX			Multipurpose End Mills · Slim Shank · Long Type	25
	B270TX			Multipurpose End Mills With Corner Radius	27
End Mills For Stainless, Titanium	E129SX			End Mills for Stainless	31
	E233SX			End Mills for Stainless	33
	E234SX			End Mills for Stainless	35
	E234-2.5SX			End Mills for Stainless	35
	E234-5.0SX			End Mills for Stainless	35
	E235-2.5SX			End Mills With Corner Radius for Stainless	37
	E235-5.0SX			End Mills With Corner Radius for Stainless	37
	E236TX			End Mills With Corner Radius for Titanium	39































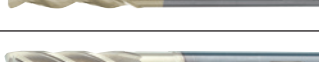

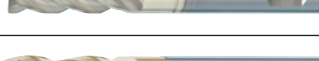

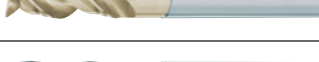

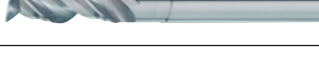

Series	Code No.	Appearance	Flute	Product Name	Page
End Mills For Aluminium	E132			End Mills For Aluminium	43
	E134			End Mills For Aluminium	43
	E142			End Mills For Aluminium	45
	E143DX			End Mills For Aluminium	47
	E143			End Mills For Aluminium	49
	E143-3.0			End Mills For Aluminium	51
	E143-4.0			End Mills For Aluminium	51
	E143-5.0			End Mills For Aluminium	51
	E145			End Mills For Aluminium	53
	E194			Utmost Finishing End Mills For Aluminium	55
	E195R			End Mills For Aluminium	57
	E195L			End Mills For Aluminium	57
	Routers For Composite Materials	E190			Routers For Composite Materials
E191				Routers For Composite Materials	61
E197				Routers For Composite Materials	63
E198				Routers For Composite Materials	63
E199				Routers For Composite Materials	63
E298				Routers For Composite Materials	65
E299				Routers For Composite Materials	65
E291				Routers For Composite Materials	67

































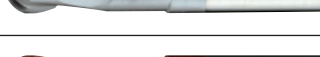

Series	Code No.	Appearance	Flute	Product Name	Page
Routers For Composite Materials	E294			Routers For Composite Materials	67
	E189R			End Mills For Plastics	69
	E189L			End Mills For Plastics	69
Short End Mills For Lathe Machine	E113X			Short End Mills For Lathe	73
	E114X			Short End Mills For Lathe	73
	E115HX			Short End Mills For Lathe	75
	E116HX			Short End Mills For Lathe	75
End Mills for Chamfering	E106X			End Mills For Chamfering 60°	79
	E107X			End Mills For Chamfering 90° / 120°	79
	E108X			End Mills For Chamfering 60°	81
	E109X			End Mills For Chamfering 90°	81
	E109X			End Mills For Chamfering 120°	81
	E121HX			End Mills for Chamfering 90°	83
	E123HX			End Mills for Chamfering 90°	83
	E110HX			End Mills For Back and Front Chamfering 30° / 60° / 90° / 120°	85
	E120HX			End Mills For Back and Front Chamfering 30° / 60° / 90° / 120°	87
Universal Finishing End Mills	E122X			Universal End Mills	91
	E125X E127X			Universal End Mills	93
	E162TX E163TX			Universal End Mills	95
	E124X			Finishing End Mills	97







































Series	Code No.	Appearance	Flute	Product Name	Page
Universal Finishing End Mills	E126X E128X			Finishing End Mills	99
	E164TX E165TX			Finishing End Mills	101
	E158TX E159TX			High Performance End Mills	103
	E168TX E169TX			High Performance End Mills	105
	E166TX E167TX			Finishing End Mills	107
Ball Nose End Mills	B222X			Ball Nose End Mills	111
	B232X B242X B246X			Ball Nose End Mills	113
	B262TX B263TX B264TX			Ball Nose End Mills	115
	B272ATX			Ball Nose End Mills	117
	B273ATX			Ball Nose End Mills	117
	B251TX			Ball Nose End Mills	119
	B261TX			Ball Nose End Mills	121
	B253TX			Ball Nose End Mills - 3 Flutes	123
	B254TX			Ball Nose End Mills - 4 Flutes	123
	B250TX			Ball Nose End Mills	125
End Mills With Corner Radius	B255X			End Mills With Corner Radius	129
	B257X			End Mills With Corner Radius	131
	B256X			End Mills With Corner Radius	133
	B258X			End Mills With Corner Radius	135
	B286TX			End Mills With Corner Radius	137







































Series	Code No.	Appearance	Flute	Product Name	Page
End Mills With Corner Radius	B275TX			High Performance End Mills With Corner Radius	139
	B277TX			High Performance End Mills With Corner Radius	141
	B259TX			Finishing End Mills With Corner Radius	143
	B269TX			Finishing End Mills With Corner Radius	143
	B271TX			High Performance End Mills With Corner Radius	145
	E105X			Taper End Mills	147
End Mills For Rib Processing	F692TX			End Mills For Rib Processing	151
	F694TX			End Mills For Rib Processing	153
	F690TX			Toric End Mills For Rib Processing With Corner Radius	155
	F693TX			Toric End Mills For Rib Processing With Corner Radius	159
	F695TX			Ball Nose End Mills For Rib Processing	161
	F691TX			End Mills For Rib Processing	163
End Mills For Graphite	G696DC			Ball Nose End Mills For Graphite	167
	G234DC			Ball Nose End Mills For Graphite	169
	G244DC			Ball Nose End Mills For Graphite	169
	G697DC			End Mills For Graphite	171
	G298DC			End Mills For Graphite	173
Drills	D921X D922X D932X			NC Spot Drills	177
	D923X D924X			NC Spot Drills	179
	D420HX-3			Micro Precision Drills	181





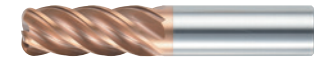



































Series	Code No.	Appearance	Flute	Product Name	Page
Drills	D420HX-5			Micro Precision Drills	185
	D420HX-8			Micro Precision Drills	189
	D421TX			High Performance Drills	193
	D422TX			High Performance Drills	192
	D423TX-3			Oil-Feed High Performance Drills	197
	D423TX-5			Oil-Feed High Performance Drills	199
	D423TX-8			Oil-Feed High Performance Drills	201
	D423TX-12 D423TX-16			Oil-Feed High Performance Drills	203
	D423TX-20 D423TX-25 D423TX-30			Oil-Feed High Performance Drills	205
	D425TX-2			Flat Bottom Drills	207
Interchangeable Cutter Heads	EMH/SM			Multipurpose End Mills	210
	EMH/SA			End Mills For Aluminium	210
	EMH/EF			Finishing End Mills	210
	EMH/BH			Ball Nose End Mills - 4 Flutes	210





































Series	Code No.	Appearance	Flute	Product Name	Page
DIN					
High Performance End Mills	F513SX			Multipurpose End Mills	215
	HF514SX			Multipurpose End Mills With Coolant Hole	217
	F514SX F515SX			Multipurpose End Mills	219
	F524SX F525SX			Premium Cut End Mills	221
	F517TX F518TX			Multipurpose End Mills	223
	F636TX			Multipurpose End Mills	223
	F608HX F609HX			Roughing End Mills	225
	F638TX F649TX			Roughing End Mills	227
	F651SX			End Mills For Difficult To Cut Materials	229
	F652SX			End Mills With Corner Radius For Difficult To Cut Materials	231
	F653SX			End Mills With Corner Radius For Difficult To Cut Materials	233
	F631ZX			End Mills For Aluminium	235
	F631 F632			End Mills For Aluminium	235
	F607ZX			Toric End Mills For Aluminium	237
	F642ZX F643ZX			Roughing End Mills For Aluminium	239
	F618ZX F620ZX			Ball Nose End Mills For Aluminium	241
Thread Mills	T740TX			Oil-Feed Thread Mills Drills	245
	T781HX			Micro Thread Mills / Oil-Feed Thread Mills	247
	T783			Micro Thread Mills / Oil-Feed Thread Mills	249

Series	Code No.	Appearance	Flute	Product Name	Page
End Mills	E102HX			Universal End Mills	253
	E104HX			Finishing End Mills	253
	F500HX F501HX			Universal End Mills	255
	F602TX			Universal End Mills	255
	F503HX F504HX			Universal End Mills	257
	F603TX			Universal End Mills	257
	F506HX F507HX			Finishing End Mills	259
	F604TX F606TX			Finishing End Mills	261
	F660TX F661TX			Finishing End Mills	263
	B202HX			Ball Nose End Mills	265
	F520HX F521HX			Ball Nose End Mills	267
	F623HX F624HX			Ball Nose End Mills	269
	F625TX F626TX			Ball Nose End Mills	271
	F615TX F619TX			Toric End Mills	273
	F613TX F614TX			Toric End Mills	275
	F676TX			High Feed End Mills	277
	Drills	D903 D904			NC Spot Drills 90° / 120°
D913 D914				NC Spot Drills 90° / 120°	281
D908				Combined Drills and Countersink 60°	283
D400				Micro Precision Drills	285

Series	Code No.	Appearance	Flute	Product Name	Page
Drills	D412			Twist Drills	287
	D430FN			High Performance Drills	287
	D413			Twist Drills	289
	D433FN			High Performance Drills	289
	D431FT			High performance Drills	291
	D435FT			Oil-Feed High Performance Drills	291
	D432FT			High performance Drills	293
	D436FT			Oil-Feed High Performance Drills	293
	D437FT			Oil-Feed High Performance Drills	295
	D415			High performance 3-Flute Drills	297
	D419FT			Combined Drill and Chamfer Tool	299
	Reamers	R300			Machine Reamers
R301				Machine Reamers	306
R302				Machine Reamers	307
R303				Machine Reamers	308
R308				Machine Reamers In Steps of 0.1mm	309
R309				NC Machine Reamers	311
R319				NC Machine Reamers In Steps of 0.01mm	313
R329				NC Machine Reamers Right Hand Helix (End Cutting)	315

Series	Code No.	Appearance	Flute	Product Name	Page
ANSI					
End Mills · Drills · Reamers	E172			Square End Mills	323
	E174			Square End Mills	323
	E182 E185 E187			Square End Mills	324
	E184 E186 E188			Square End Mills	324
	B212			Ball Nose End Mills	325
	B214			Ball Nose End Mills	325
	B280 B282			Ball Nose End Mills	326
	B281 B284			Ball Nose End Mills	326
	E133			End Mills For Aluminium	327
	E135 E136 E137			End Mills For Aluminium	328
	D453			Jobber Drills	329
	R391			NC Machine Reamers	331
	High Performance End Mills	S445HX			Easy Cut End Mills
E141-1HX				Multipurpose End Mills	336
E141-2HX E141-3HX				Multipurpose End Mills	337
F651SX				End Mills For Difficult To Cut Materials	338
F652SX				End Mills With Corner Radius For Difficult To Cut Materials	339
F653TX				End Mills With Corner Radius For Difficult To Cut Materials	340
E143-1			End Mills For Aluminium	341	

Series	Code No.	Appearance	Flute	Product Name	Page
End Mills For Aluminium	E143-2			End Mills For Aluminium	342
	E143-3			End Mills For Aluminium	342
	E133			End Mills For Aluminium	343
	E135			End Mills For Aluminium	344
	E136			End Mills For Aluminium	344
End Mills	E172			Square End Mills	347
	E174			Square End Mills	347
	E182 E185			Square End Mills	348
	E184 E186			Square End Mills	348
	E166TX			Finishing End Mills	349
	F608HX			Roughing End Mills	350
	B212			Ball Nose End Mills	351
	B214			Ball Nose End Mills	351
	B280			Ball Nose End Mills	352
	B282			Ball Nose End Mills	352
	B281			Ball Nose End Mills	352
	B284			Ball Nose End Mills	352
	E191			Routing End Mills	353
	E197			Routing End Mills	354
	E198			Routing End Mills	354

Series	Code No.	Appearance	Flute	Product Name	Page
	E199			Routing End Mills	354
End Mills For Chamfering	E106X			Chamfer Mills	355
	E107X			Chamfer Mills	355
	E108X			Chamfer Mills	356
	E109X			Chamfer Mills	356
	E100HX			Double Angle Cutter	357
	Drills - Reamers	D908			Combined Drills & Countersinks
D901				NC Spot Drills	362
D903				NC Spot Drills	362
D913				NC Spot Drills	362
D451				Straight Flute Drills	363
D452				Slow Spiral Screw Machine Drills	365
D453				Jobber Drills	367
R391				NC Machine Reamers	369
Interchangeable Cutter Heads	EMH/SM			Multipurpose End Mills	372
	EMH/SA			End Mills For Aluminium	372
	EMH/EF			Finishing End Mills	372
	EMH/BH			Ball Nose End Mills - 4 Flutes	372

POPULAR PRODUCT

Page. 5/7/9

E140HX / E141HX

Multipurpose End Mills

Special design for chip evacuation, uneven flutes distribution and variable helix design.

Suitable for drilling, milling, slotting, and processing with larger cutting width.

●1.5D ●2.0D ●2.5D
●3.0D ●4.0D ●5.0D



Page. 35/37

E234SX

End Mills For Stainless

Uneven flute distributions with five flutes which are effective in reducing vibration to allow deeper cutting and high speed cutting.

Widely applied to rough, high speed and finish processing on varied Metal working materials, Stainless steel and High Temp Alloys.

ASIA



Page. 49

E143

End Mills For Aluminium

Design with non-sticky cutting and shine surface appearance. Suitable for roughing and finishing process on aluminium.



Page. 85/87

E110HX/E120HX

End Mills For Back and Front Chamfering 30°/60°/90°/120°

With great heat resistance, applicable in high performance processing.
Suitable for hardened steel, stainless steel, carbon steel, non-ferrous metals and other difficult-to-cut materials.



Page. 207

D425TX-2

Flat Bottom Drills

With 0° point of drill tip, it can avoid shift or skewing on non-planar drilling suitable for countersinks, ramping, curved surface...etc.



Series

Page. 83

E121HX / E123HX

End Mills For Chamfering 90°

With Helix cutting edge design, reduce vibration during cutting process.
Sharp cutting edge could get better surface roughness and reduce burrs.



Multipurpose End Mills

Page	3	5	7	9	11	13
Apperance						
Code No	E130HX	E140HX	E141-1.5HX E141-2.0HX E141-3.0HX	E141-4.0HX E141-5.0HX	E144X	E144-4.0X E144-5.0X E144-6.0X
Carbide	MG Carbide	MG Carbide	MG Carbide	MG Carbide	UMG Carbide	UMG Carbide
Coating	AlTiCrN HX	AlTiCrN HX	AlTiCrN HX	AlTiCrN HX	AlTiXN X	AlTiXN X
Helix Angle	 38° 41°	 38° 41°	 38° 41°	 38° 41°	 43° 48°	 43° 48°
No.of Flutes	 3	 4	 4	 4	 4	 4

ASIA

15

19

21

23

25

27



B252-2.5HX

B274HX

F612HX
F617HX

E148HX

E149HX

B270TX

UMG
Carbide

UMG
Carbide

UMG
Carbide

MG
Carbide

MG
Carbide

UMG
Carbide

AlTiCrN
HX

AlTiCrN
HX

AlTiCrN
HX

AlTiCrN
HX

AlTiCrN
HX

AlTiSiN
TX



E130HX

Multipurpose End Mills

MG
Carbide

AlTiCrN
HX



Type of Operation



Work Material

P	H	M	K	N	S
●	●	●	●	○	○

P Steel

H <38HRC
Hardened Steel

H <48HRC
Hardened Steel

M Stainless Steel

K Cast Iron

N Aluminium

N Copper

S Titanium

S Nickel

S High Temp Alloys

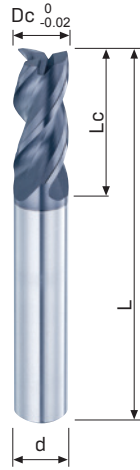

Code No. E130HX-Dc

Dc	Lc	L	d	AlTiCrN
$\begin{matrix} 0 \\ -0.02 \end{matrix}$	mm	mm	h6	E130HX
1	3	50	4	●
1.5	5	50	4	●
2	6	50	4	●
2.5	8	50	4	●
3A	8	50	4	●
4A	11	50	4	●
3	8	50	6	●
3.5	10	50	6	●
4	11	50	6	●
4.5	11	50	6	●
5	13	50	6	●
5.5	13	50	6	●
6	16	50	6	●
6.5	16	60	8	●
7	20	60	8	●
7.5	20	60	8	●
8	20	60	8	●
8.5	20	72	10	●
9	22	72	10	●
9.5	22	72	10	●
10	22	72	10	●
11	26	75	12	●
12	26	75	12	●
14	32	90	16	●
16	38	100	16	●
18	38	100	20	●
20	38	100	20	●

Feature of product:

Multipurpose End Mills- 3 Flutes
Effectively decrease the vibration by the designs of various helix geometry and unequal flutes.

Big chip breaker is designed to reach high removal rate for various work materials.

Obviously improving tool life with Nano multilayer coating AlTiCrN.

Suitable for different kinds of materials cutting.

Side Milling

Work Material		GR.1 Carbon Steel		GR.2 Low-alloyed Steel (~24HRC)		GR.3 Hi-alloyed Steel (~30HRC)		GR.4 Hardened Steel (30-38HRC)		GR.5 Hardened Steel (38-48HRC)		GR.8 Stainless Steel		GR.9 Cast Iron		GR.15 Titanium	
Vc m/min		100		100		80		65		60		65		100		30	
Code No.	Dc	RPM (min-1)	Feed (mm/min)	RPM (min-1)	Feed (mm/min)	RPM (min-1)	Feed (mm/min)	RPM (min-1)	Feed (mm/min)	RPM (min-1)	Feed (mm/min)	RPM (min-1)	Feed (mm/min)	RPM (min-1)	Feed (mm/min)	RPM (min-1)	Feed (mm/min)
E130HX-1	1	18,000	200	18,000	200	14,500	150	12,800	140	12,800	140	12,800	140	18,000	200	12,800	50
E130HX-1.5	1.5	15,000	220	15,000	220	12,500	180	11,000	160	11,000	160	11,000	160	15,000	220	11,200	52
E130HX-2	2	12,000	400	12,000	400	10,000	300	9,500	230	9,500	230	9,500	230	12,000	400	8,200	50
E130HX-2.5	2.5	10,000	450	10,000	450	8,000	400	7,600	250	7,600	250	7,600	250	10,000	450	5,000	52
E130HX-3	3	9,000	600	9,000	600	6,600	550	6,000	300	3,800	80	6,000	300	9,000	600	3,100	50
E130HX-4	4	6,600	650	6,600	650	5,000	630	4,500	350	2,800	90	4,500	350	6,600	650	2,300	60
E130HX-5	5	5,300	700	5,300	700	4,000	635	3,500	360	2,200	95	3,500	360	5,300	700	1,900	65
E130HX-6	6	5,300	720	5,300	720	4,000	645	3,500	300	2,200	130	3,500	300	5,300	720	1,900	80
E130HX-8	8	4,000	700	4,000	700	3,000	565	2,600	200	1,600	140	2,600	200	4,000	700	1,400	90
E130HX-10	10	3,200	620	3,200	620	2,400	550	2,100	230	1,300	140	2,100	230	3,200	620	1,100	95
E130HX-12	12	2,600	580	2,600	580	2,000	500	1,700	225	1,100	115	1,700	225	2,600	580	1,000	80
E130HX-14	14	2,300	550	2,300	550	1,800	450	1,400	200	900	100	1,400	200	230	550	900	70
E130HX-16	16	2,000	500	2,000	500	1,500	400	1,300	160	830	90	1,300	160	2,000	500	720	65
E130HX-18	18	1,800	450	1,800	450	1,400	350	1,200	140	700	80	1,200	140	1,800	450	650	65
E130HX-20	20	1,500	420	1,500	420	1,200	315	1,000	150	650	70	1,000	150	1,500	420	600	65
(mm) 		ap:1.5D		ap:1.5D		ap:1.5D		ap:1.5D		ap:1.5D		ap:1.5D		ap:1.5D		ap:1.5D	
		ae:0.2D		ae:0.2D		ae:0.2D		ae:0.2D		ae:0.1D		ae:0.2D		ae:0.2D		ae:0.1D	

Plunge milling

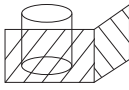
Work Material		GR.1 Carbon Steel		GR.2 Low-alloyed Steel (~24HRC)		GR.3 Hi-alloyed Steel (~30HRC)		GR.4 Hardened Steel (30-38HRC)		GR.5 Hardened Steel (38-48HRC)		GR.8 Stainless Steel		GR.9 Cast Iron		GR.15 Titanium	
Vc m/min		100		100		80		65		60		65		100		30	
Code No.	Dc	RPM (min-1)	Feed (mm/min)	RPM (min-1)	Feed (mm/min)	RPM (min-1)	Feed (mm/min)	RPM (min-1)	Feed (mm/min)	RPM (min-1)	Feed (mm/min)	RPM (min-1)	Feed (mm/min)	RPM (min-1)	Feed (mm/min)	RPM (min-1)	Feed (mm/min)
E130HX-3	3	8,500	320	8,500	320	6,300	200	5,800	110	5,800	110	5,800	105	8,500	320	4,800	80
E130HX-4	4	6,300	350	6,300	350	4,700	205	4,200	110	4,200	110	4,200	110	6,300	350	3,600	85
E130HX-5	5	5,000	350	5,000	350	3,800	210	3,500	120	3,500	120	3,500	125	5,000	350	2,800	90
E130HX-6	6	4,200	380	4,200	380	3,200	220	2,800	130	2,800	130	2,800	120	4,200	380	2,400	95
E130HX-8	8	3,200	350	3,200	350	2,400	210	2,200	120	2,200	120	2,200	120	3,200	350	1,800	85
E130HX-10	10	2,500	300	2,500	300	1,800	180	1,700	100	1,700	100	1,700	105	2,500	300	1,500	70
E130HX-12	12	2,000	300	2,000	300	1,600	190	1,400	100	1,400	100	1,400	100	2,000	300	1,200	70
E130HX-14	14	1,800	200	1,800	200	1,400	160	1,300	80	1,300	80	1,300	80	1,800	200	1,000	60
E130HX-16	16	1,500	180	1,500	180	1,200	140	1,200	80	1,200	80	1,200	80	1,500	180	800	60
E130HX-18	18	1,400	150	1,400	150	1,000	120	1,000	60	1,000	60	1,000	60	1,400	150	700	50
E130HX-20	20	1,300	100	1,300	100	800	80	800	60	800	60	800	60	1,300	100	600	50
(mm) 		ap:1.5D		ap:1.5D		ap:1.5D		ap:1.5D		ap:1.5D		ap:1.5D		ap:1.5D		ap:1.5D	
		ae:0.2D		ae:0.2D		ae:0.2D		ae:0.2D		ae:0.1D		ae:0.2D		ae:0.2D		ae:0.1D	

1. Please work with good rigidity / high precision facilities and collet chuck.
2. Please choose proper cutting fluid.
3. The cutting data is reference value only. Please adjust it according to your real working conditions.
4. If RPM is lower the reference value, the Feed rate (fz) and RPM should be reduced by the same proportion.
5. If vibration occurs during cutting, please reduce cutting parameter.

E140HX

Multipurpose End Mills

Code No. E140HX-Dc

MG
Carbide

AlTiCrN
HX

Type of Operation

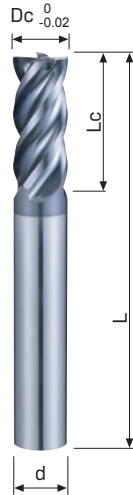

Dc	Lc	L	d	AlTiCrN	Dc	Lc	L	d	AlTiCrN
$\begin{matrix} 0 \\ -0.02 \end{matrix}$	mm	mm	h6	E140HX	$\begin{matrix} 0 \\ -0.02 \end{matrix}$	mm	mm	h6	E140HX
1	3	50	4	●	7.2	20	60	8	●
1.1	3	50	4	●	7.3	20	60	8	●
1.2	4	50	4	●	7.4	20	60	8	●
1.3	4	50	4	●	7.5	20	60	8	●
1.4	4	50	4	●	7.6	20	60	8	●
1.5	5	50	4	●	7.7	20	60	8	●
1.6	5	50	4	●	7.8	20	60	8	●
1.7	5	50	4	●	7.9	20	60	8	●
1.8	5	50	4	●	8	20	60	8	●
1.9	5	50	4	●	8.1	20	72	10	●
2	6	50	4	●	8.2	20	72	10	●
2.1	6	50	4	●	8.3	20	72	10	●
2.2	6	50	4	●	8.4	20	72	10	●
2.3	6	50	4	●	8.5	20	72	10	●
2.4	8	50	4	●	8.6	22	72	10	●
2.5	8	50	4	●	8.7	22	72	10	●
2.6	8	50	4	●	8.8	22	72	10	●
2.7	8	50	4	●	8.9	22	72	10	●
2.8	8	50	4	●	9	22	72	10	●
2.9	8	50	4	●	9.1	22	72	10	●
3A	8	50	4	●	9.2	22	72	10	●
4A	11	50	4	●	9.3	22	72	10	●
3	8	50	6	●	9.4	22	72	10	●
3.1	10	50	6	●	9.5	22	72	10	●
3.2	10	50	6	●	9.6	22	72	10	●
3.3	10	50	6	●	9.7	22	72	10	●
3.4	10	50	6	●	9.8	22	72	10	●
3.5	10	50	6	●	9.9	22	72	10	●
3.6	10	50	6	●	10	22	72	10	●
3.7	10	50	6	●	10-25	25	72	10	●
3.8	11	50	6	●	10.1	22	75	12	●
3.9	11	50	6	●	10.2	22	75	12	●
4	11	50	6	●	10.3	22	75	12	●
4.1	11	50	6	●	10.4	22	75	12	●
4.2	11	50	6	●	10.5	22	75	12	●
4.3	11	50	6	●	10.6	26	75	12	●
4.4	11	50	6	●	10.7	26	75	12	●
4.5	11	50	6	●	10.8	26	75	12	●
4.6	11	50	6	●	10.9	26	75	12	●
4.7	11	50	6	●	11	26	75	12	●
4.8	13	50	6	●	11.1	26	75	12	●
4.9	13	50	6	●	11.2	26	75	12	●
5	13	50	6	●	11.3	26	75	12	●
5.1	13	50	6	●	11.4	26	75	12	●
5.2	13	50	6	●	11.5	26	75	12	●
5.3	13	50	6	●	11.6	26	75	12	●
5.4	13	50	6	●	11.7	26	75	12	●
5.5	13	50	6	●	11.8	26	75	12	●
5.6	16	50	6	●	11.9	26	75	12	●
5.7	16	50	6	●	12	26	75	12	●
5.8	16	50	6	●	12-30	30	75	12	●
5.9	16	50	6	●	13	26	80	12	●
6	16	50	6	●	14	32	90	16	●
6.1	16	60	8	●	15	38	100	16	●
6.2	16	60	8	●	16	38	100	16	●
6.3	16	60	8	●	17	38	100	20	●
6.4	16	60	8	●	18	38	100	20	●
6.5	16	60	8	●	19	38	100	20	●
6.6	20	60	8	●	20	38	100	20	●
6.7	20	60	8	●	25	45	120	25	●
6.8	20	60	8	●					
6.9	20	60	8	●					
7	20	60	8	●					
7.1	20	60	8	●					

Work Material

P	H	M	K	N	S
●	●	●	●	○	○

P Steel

H <38HRC
Hardened Steel

H <48HRC
Hardened Steel

M Stainless Steel

K Cast Iron

N Aluminium

N Copper

S Titanium

S Nickel

S High Temp Alloys

Feature of product:

Multipurpose End Mills- 4 Flutes
Effectively decrease the vibration by various helix geometry and unequal flutes designs.

Big chip breaker is designed to reach high removal rate for various work materials.

Obviously improving tool life with Nano multilayer coating AlTiCrN.

Suitable for different kinds of materials cutting.

Side Milling

Work Material		GR.1 Carbon Steel		GR.2 Low-alloyed Steel (~24HRC)		GR.3 Hi-alloyed Steel (~30HRC)		GR.4 Hardened Steel (30~38HRC)		GR.5 Hardened Steel (38~48HRC)		GR.8 Stainless Steel		GR.9 Cast Iron		GR.15 Titanium		
Vc m/min		120		120		80		65		60		65		120		30		
Code No.	Dc	RPM (min-l)	Feed (mm/min)	RPM (min-l)	Feed (mm/min)	RPM (min-l)	Feed (mm/min)	RPM (min-l)	Feed (mm/min)	RPM (min-l)	Feed (mm/min)	RPM (min-l)	Feed (mm/min)	RPM (min-l)	Feed (mm/min)	RPM (min-l)	Feed (mm/min)	
E140HX-1	1	31,800	240	31,800	240	25,000	210	19,750	180	19,000	85	19,750	180	31,800	240	7,100	50	
E140HX-1.5	1.5	21,200	245	21,200	245	16,500	210	13,000	180	12,700	90	13,000	180	21,200	245	5,100	100	
E140HX-2	2	15,900	245	15,900	245	12,420	210	9,850	180	9,550	90	9,850	180	15,900	245	4,000	120	
E140HX-2.5	2.5	12,700	370	12,700	370	9,930	300	7,900	275	7,600	90	7,900	275	12,700	370	3,200	150	
E140HX-3	3	10,600	683	10,600	683	8,280	530	6,550	389	6,400	105	6,550	389	10,600	683	3,200	180	
E140HX-4	4	6,350	735	6,350	735	4,950	590	3,950	413	3,800	120	3,950	413	6,350	735	2,400	180	
E140HX-5	5	4,550	875	4,550	875	3,550	625	2,800	448	2,730	125	2,800	448	4,550	875	2,000	190	
E140HX-6	6	3,540	875	3,540	875	2,760	600	2,200	413	2,100	125	2,200	413	3,540	875	1,600	190	
E140HX-7	7	3,360	820	3,360	820	2,620	600	2,075	413	2,000	125	2,075	413	3,360	820	1,400	180	
E140HX-8	8	3,185	770	3,185	770	2,480	600	1,975	413	1,900	125	1,975	413	3,185	770	1,200	170	
E140HX-9	9	3,410	770	3,410	770	2,280	595	1,800	390	1,750	120	1,800	390	3,410	770	1,100	165	
E140HX-10	10	3,650	770	3,650	770	2,070	595	1,645	375	1,595	120	1,645	375	3,650	770	1,000	160	
E140HX-11	11	2,950	720	2,950	720	1,920	575	1,520	360	1,475	120	1,520	360	2,275	720	900	160	
E140HX-12	12	2,275	670	2,275	670	1,770	560	1,410	350	1,365	120	1,410	350	2,275	670	800	160	
E140HX-14	14	2,040	670	2,040	670	1,590	540	1,360	320	1,250	100	1,360	350	2,040	670	700	150	
E140HX-16	16	1,990	670	1,990	670	1,550	520	1,230	312	1,190	100	1,230	312	1,990	670	600	150	
E140HX-18	18	1,770	550	1,770	550	1,410	450	1,060	300	1,060	90	1,060	330	1,770	550	500	150	
E140HX-20	20	1,590	535	1,590	535	1,240	415	985	277	950	90	985	277	1,590	535	480	160	
E140HX-25	25	1,270	420	1,270	420	1,000	330	760	210	750	70	790	210	1,270	420	380	120	
		ap:1.5D		ap:1.5D		ap:1.5D		ap:1.5D		ap:1.5D		ap:1.5D		ap:1.5D		ap:1.5D		
		ae:0.2D		ae:0.2D		ae:0.2D		ae:0.2D		ae:0.1D		ae:0.2D		ae:0.2D		ae:0.1D		ae:0.1D

Slotting

Work Material		GR.1 Carbon Steel		GR.2 Low-alloyed Steel (~24HRC)		GR.3 Hi-alloyed Steel (~30HRC)		GR.4 Hardened Steel (30~38HRC)		GR.5 Hardened Steel (38~48HRC)		GR.8 Stainless Steel		GR.9 Cast Iron		GR.15 Titanium		
Vc m/min		120		120		80		65		60		65		120		30		
Code No.	Dc	RPM (min-l)	Feed (mm/min)	RPM (min-l)	Feed (mm/min)	RPM (min-l)	Feed (mm/min)	RPM (min-l)	Feed (mm/min)	RPM (min-l)	Feed (mm/min)	RPM (min-l)	Feed (mm/min)	RPM (min-l)	Feed (mm/min)	RPM (min-l)	Feed (mm/min)	
E140HX-1	1	31,800	200	31,800	200	25,000	180	19,750	150	19,000	85	19,750	150	31,800	200	7,100	50	
E140HX-1.5	1.5	21,200	200	21,200	200	16,500	180	13,000	150	12,700	90	13,000	150	21,200	200	5,100	80	
E140HX-2	2	15,900	220	15,900	220	12,420	180	9,850	150	9,550	90	9,850	150	15,900	220	4,000	100	
E140HX-2.5	2.5	12,700	330	12,700	330	9,930	220	7,900	175	7,600	90	7,900	175	12,700	330	3,200	100	
E140HX-3	3	10,600	600	10,600	600	8,280	430	6,550	290	6,400	105	6,550	290	10,600	600	3,200	130	
E140HX-4	4	6,350	635	6,350	635	4,950	500	3,950	325	3,800	120	3,950	325	6,350	635	2,400	150	
E140HX-5	5	4,550	775	4,550	775	3,550	525	2,800	348	2,730	125	2,800	348	4,550	775	2,000	160	
E140HX-6	6	3,540	775	3,540	775	2,760	500	2,200	313	2,100	125	2,200	313	3,540	775	1,600	145	
E140HX-7	7	3,360	710	3,360	710	2,620	500	2,075	313	2,000	125	2,075	313	3,360	710	1,400	130	
E140HX-8	8	3,185	650	3,185	650	2,480	500	1,975	313	1,900	125	1,975	313	3,185	650	1,200	120	
E140HX-9	9	3,410	660	3,410	660	2,280	495	1,800	300	1,750	120	1,800	300	3,410	660	1,100	130	
E140HX-10	10	3,650	670	3,650	670	2,070	490	1,645	288	1,595	120	1,645	288	3,650	670	1,000	145	
E140HX-11	11	2,950	615	2,950	615	1,920	475	1,520	280	1,475	120	1,520	280	2,275	615	900	150	
E140HX-12	12	2,275	560	2,275	560	1,770	460	1,410	275	1,365	120	1,410	275	2,275	560	800	150	
E140HX-14	14	2,040	500	2,040	500	1,590	440	1,360	250	1,250	100	2,040	250	2,040	660	700	150	
E140HX-16	16	1,990	660	1,990	660	1,550	420	1,230	240	1,190	100	1,230	240	1,990	660	600	150	
E140HX-18	18	1,770	550	1,770	550	1,410	400	1,060	230	970	90	1,770	220	1,770	500	500	140	
E140HX-20	20	1,590	500	1,590	500	1,240	360	985	200	950	90	985	200	1,590	500	480	130	
		ap:0.5D		ap:0.5D		ap:0.5D		ap:0.5D		ap:0.05D		ap:0.5D		ap:0.5D		ap:0.05D		
		ap:0.5D		ap:0.5D		ap:0.5D		ap:0.5D		ap:0.05D		ap:0.5D		ap:0.5D		ap:0.05D		ap:0.05D

E141-1.5HX / 2.0HX / 3.0HX

Multipurpose End Mills

MG Carbide **AlTiCrN HX**



Type of Operation

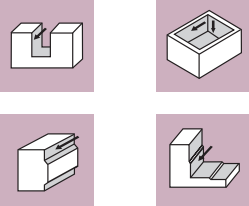

Work Material

P	H	M	K	N	S
●	●	●	●	○	○

- P** Steel
- H** <38HRC Hardened Steel
- H** <48HRC Hardened Steel
- M** Stainless Steel
- K** Cast Iron
- N** Aluminium
- N** Copper
- S** Titanium
- S** Nickel
- S** High Temp Alloys

Feature of product:

Multipurpose End Mills- 4 Flutes with various short and long length types
Effectively decrease the vibration by various helix geometry and unequal flutes designs.
Big chip breaker is designed to reach high removal rate for various work materials.
Obviously improving tool life with Nano multilayer coating AlTiCrN.
Suitable for different kinds of materials cutting.

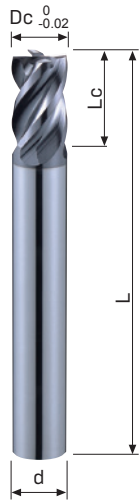

Code No. E141-1.5HX-Dc

Dc 0 -0.02	Lc mm	L mm	d h6	AlTiCrN E141-1.5HX
1	1.5	50	4	●
1.5	2.3	50	4	●
2	3	50	4	●
2.5	3.8	50	4	●
3	4.5	50	6	●
3.5	5.3	50	6	●
4	6	50	6	●
4.5	6.8	50	6	●
5	7.5	50	6	●
5.5	8.3	50	6	●
6	9	50	6	●
8	12	65	8	●
10	15	75	10	●
12	18	80	12	●
16	24	100	16	●
20	30	120	20	●

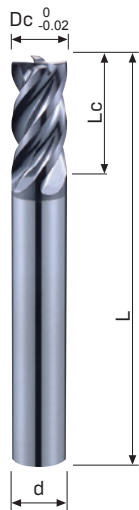

Code No. E141-2.0HX-Dc

Dc 0 -0.02	Lc mm	L mm	d h6	AlTiCrN E141-2.0HX
1	2	50	4	●
1.5	3	50	4	●
2	4	50	4	●
2.5	5	50	4	●
3	6	50	6	●
3.5	7	50	6	●
4	8	50	6	●
4.5	9	50	6	●
5	10	50	6	●
5.5	11	50	6	●
6	12	50	6	●
8	16	65	8	●
10	20	75	10	●
12	24	80	12	●
16	32	100	16	●
20	40	120	20	●

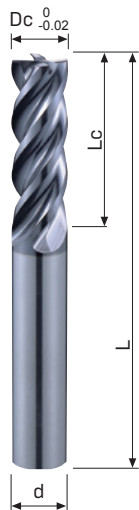

Code No. E141-3.0HX-Dc

Dc 0 -0.02	Lc mm	L mm	d h6	AlTiCrN E141-3.0HX	Dc 0 -0.02	Lc mm	L mm	d h6	AlTiCrN E141-3.0HX
1	3	50	4	●	10	30	75	10	●
1.5	4.5	50	4	●	11	33	80	12	●
2	6	50	4	●	12	36	80	12	●
2.5	7.5	50	4	●	13	39	100	16	●
3	9	50	6	●	14	42	100	16	●
3.5	10.5	50	6	●	15	45	100	16	●
4	12	50	6	●	16	48	100	16	●
4.5	13.5	50	6	●	17	51	120	20	●
5	15	50	6	●	18	54	120	20	●
5.5	16.5	50	6	●	20	60	120	20	●
6	18	50	6	●	25	75	150	25	●
7	21	65	8	●					
8	24	65	8	●					
9	27	75	10	●					

E141-1.5HX / 2.0HX / 3.0HX

Recommended Milling Conditions

E141-1.5HX / 2.0HX / Slotting

Work Material		GR.1 Carbon Steel		GR.2 Low-alloyed Steel (~24HRC)		GR.3 Hi-alloyed Steel (~30HRC)		GR.4 Hardened Steel (30-38HRC)		GR.5 Hardened Steel (38-48HRC)		GR.8 Stainless Steel		GR.9 Cast Iron		GR.15 Titanium	
Vc m/min		120		120		80		65		60		65		120		30	
Code No.	Dc	RPM (min-1)	Feed (mm/min)	RPM (min-1)	Feed (mm/min)	RPM (min-1)	Feed (mm/min)	RPM (min-1)	Feed (mm/min)	RPM (min-1)	Feed (mm/min)	RPM (min-1)	Feed (mm/min)	RPM (min-1)	Feed (mm/min)	RPM (min-1)	Feed (mm/min)
E141-1.5HX/2.0HX-1	1	31,800	200	31,800	200	25,000	180	19,750	150	19,000	85	19,750	150	31,800	200	7,100	50
E141-1.5HX/2.0HX-1.5	1.5	21,200	200	21,200	200	16,500	180	13,000	150	12,700	90	13,000	150	21,200	200	5,100	80
E141-1.5HX/2.0HX-2	2	15,900	220	15,900	220	12,420	180	9,850	150	9,550	90	9,850	150	15,900	220	4,000	100
E141-1.5HX/2.0HX-2.5	2.5	12,700	330	12,700	330	9,930	220	7,900	175	7,600	90	7,900	175	12,700	330	3,200	100
E141-1.5HX/2.0HX-3	3	10,600	600	10,600	600	8,280	430	6,550	290	6,400	105	6,550	290	10,600	600	3,200	130
E141-1.5HX/2.0HX-3.5	3.5	8,470	615	8,470	615	6,600	465	5,250	305	5,100	110	5,250	305	8,470	615	2,800	140
E141-1.5HX/2.0HX-4	4	6,350	635	6,350	635	4,950	500	3,950	325	3,800	120	3,950	325	6,350	635	2,400	150
E141-1.5HX/2.0HX-4.5	4.5	5,450	705	5,450	705	4,250	510	3,370	335	3,260	120	3,370	335	5,450	705	2,200	155
E141-1.5HX/2.0HX-5	5	4,550	775	4,550	775	3,550	525	2,800	348	2,730	125	2,800	348	4,550	775	2,000	160
E141-1.5HX/2.0HX-5.5	5.5	4,040	775	4,040	775	3,160	510	2,500	330	2,400	125	2,500	330	4,040	775	1,800	150
E141-1.5HX/2.0HX-6	6	3,540	775	3,540	775	2,760	500	2,200	313	2,100	125	2,200	313	3,540	775	1,600	145
E141-1.5HX/2.0HX-8	8	3,185	650	3,185	650	2,480	500	1,975	313	1,900	125	1,975	313	3,185	650	1,200	120
E141-1.5HX/2.0HX-10	10	3,650	670	3,650	670	2,070	490	1,645	288	1,595	120	1,645	288	3,650	670	1,000	145
E141-1.5HX/2.0HX-12	12	2,275	560	2,275	560	1,770	460	1,410	275	1,365	120	1,410	275	2,275	560	800	150
E141-1.5HX/2.0HX-16	16	1,990	660	1,990	660	1,550	420	1,230	240	1,190	100	1,230	240	1,990	660	600	150
E141-1.5HX/2.0HX-20	20	1,590	500	1,590	500	1,240	360	985	200	950	90	985	200	1,590	500	480	130
(mm)		ap:0.5D		ap:0.5D		ap:0.5D		ap:0.5D		ap:0.05D		ap:0.5D		ap:0.5D		ap:0.05D	

E141-3.0HX / Side Milling

Work Material		GR.1 Carbon Steel		GR.2 Low-alloyed Steel (~24HRC)		GR.3 Hi-alloyed Steel (~30HRC)		GR.4 Hardened Steel (30-38HRC)		GR.5 Hardened Steel (38-48HRC)		GR.8 Stainless Steel		GR.9 Cast Iron		GR.15 Titanium	
Vc m/min		120		120		80		65		60		65		120		30	
Code No.	Dc	RPM (min-1)	Feed (mm/min)	RPM (min-1)	Feed (mm/min)	RPM (min-1)	Feed (mm/min)	RPM (min-1)	Feed (mm/min)	RPM (min-1)	Feed (mm/min)	RPM (min-1)	Feed (mm/min)	RPM (min-1)	Feed (mm/min)	RPM (min-1)	Feed (mm/min)
E141-3.0HX-1	1	31,800	240	31,800	240	25,000	210	19,750	180	19,000	85	19,750	180	31,800	240	7,100	50
E141-3.0HX-1.5	1.5	21,200	245	21,200	245	16,500	210	13,000	180	12,700	90	13,000	180	21,200	245	5,100	100
E141-3.0HX-2	2	15,900	245	15,900	245	12,420	210	9,850	180	9,550	90	9,850	180	15,900	245	4,000	120
E141-3.0HX-2.5	2.5	12,700	370	12,700	370	9,930	300	7,900	275	7,600	90	7,900	275	12,700	370	3,200	150
E141-3.0HX-3	3	10,600	683	10,600	683	8,280	530	6,550	389	6,400	105	6,550	389	10,600	683	3,200	180
E141-3.0HX-3.5	3.5	8,470	710	8,470	710	6,600	560	5,250	400	5,100	110	5,250	400	8,470	710	2,800	180
E141-3.0HX-4	4	6,350	735	6,350	735	4,950	590	3,950	413	3,800	120	3,950	413	6,350	735	2,400	180
E141-3.0HX-4.5	4.5	5,450	805	5,450	805	4,250	605	3,370	428	3,260	120	3,370	428	5,450	805	2,200	185
E141-3.0HX-5	5	4,550	875	4,550	875	3,550	625	2,800	448	2,730	125	2,800	448	4,550	875	2,000	190
E141-3.0HX-5.5	5.5	4,040	875	4,040	875	3,160	610	2,500	428	2,400	125	2,500	428	4,040	875	1,800	190
E141-3.0HX-6	6	3,540	875	3,540	875	2,760	600	2,200	413	2,100	125	2,200	413	3,540	875	1,600	190
E141-3.0HX-8	8	3,185	770	3,185	770	2,480	600	1,975	413	1,900	125	1,975	413	3,185	770	1,200	170
E141-3.0HX-10	10	3,650	770	3,650	770	2,070	595	1,645	375	1,595	120	1,645	375	3,650	770	1,000	160
E141-3.0HX-12	12	2,275	670	2,275	670	1,770	560	1,410	350	1,365	120	1,410	350	2,275	670	800	160
E141-3.0HX-16	16	1,990	670	1,990	670	1,550	520	1,230	312	1,190	100	1,230	312	1,990	670	600	150
E141-3.0HX-20	20	1,590	535	1,590	535	1,240	415	985	277	950	90	985	277	1,590	535	480	160
E141-3.0HX-25	25	1,270	420	1,270	420	1,000	330	760	210	750	70	790	210	1,270	420	380	120
(mm)		ap:1.5D		ap:1.5D		ap:1.5D		ap:1.5D		ap:1.5D		ap:1.5D		ap:1.5D		ap:1.5D	
		ae:0.2D		ae:0.2D		ae:0.2D		ae:0.2D		ae:0.1D		ae:0.2D		ae:0.2D		ae:0.1D	

1. Please work with good rigidity / high precision facilities and collet chuck.
2. Please choose proper cutting fluid.
3. The cutting data is reference value only. Please adjust it according to your real working conditions.
4. If RPM is lower the reference value, the Feed rate (fz) and RPM should be reduced by the same proportion.
5. If vibration occurs during cutting, please reduce cutting parameter.

E141-4.OHX / 5.OHX

Multipurpose End Mills

MG
Carbide

AlTiCrN
HX



Type of Operation



Work Material

P	H	M	K	N	S
●	●	●	●	○	○

P Steel

H <38HRC
Hardened Steel

H <48HRC
Hardened Steel

M Stainless Steel

K Cast Iron

N Aluminium

N Copper

S Titanium

S Nickel

S High Temp Alloys

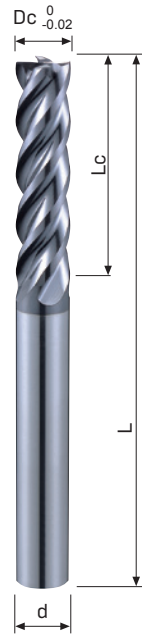

Code No. E141-4.OHX-Dc

Dc 0 -0.02	Lc mm	L mm	d h6	AlTiCrN E141-4.OHX
1	4	50	4	●
1.5	6	50	4	●
2	8	50	4	●
2.5	10	50	4	●
3	12	50	6	●
3.5	14	50	6	●
4	16	55	6	●
4.5	18	55	6	●
5	20	60	6	●
5.5	22	65	6	●
6	24	65	6	●
8	32	90	8	●
10	40	100	10	●
12	48	110	12	●
16	64	140	16	●
20	80	160	20	●



Code No. E141-5.OHX-Dc

Dc 0 -0.02	Lc mm	L mm	d h6	AlTiCrN E141-5.OHX
1	5	50	4	●
1.5	7.5	50	4	●
2	10	50	4	●
2.5	12.5	50	4	●
3	15	55	6	●
3.5	17.5	60	6	●
4	20	60	6	●
4.5	22.5	65	6	●
5	25	65	6	●
5.5	27.5	75	6	●
6	30	75	6	●
8	40	90	8	●
10	50	100	10	●
12	60	110	12	●
16	80	160	16	●
20	100	200	20	●

Feature of product:

Multipurpose End Mills- 4 Flutes with various short and long length types

Effectively decrease the vibration by various helix geometry and unequal flutes designs.

Big chip breaker is designed to reach high removal rate for various work materials.

Obviously improving tool life with Nano multilayer coating AlTiCrN.

Suitable for different kinds of materials cutting.

E141-4.0HX / 5.0HX

Recommended Milling Conditions

E141-4.0HX / Side Milling

Work Material		GR.1 Carbon Steel		GR.2 Low-alloyed Steel (~24HRC)		GR.3 Hi-alloyed Steel (~30HRC)		GR.4 Hardened Steel (30-38HRC)		GR.5 Hardened Steel (38-48HRC)		GR.8 Stainless Steel		GR.9 Cast Iron		GR.15 Titanium	
Vc m/min		90		90		60		50		45		50		90		23	
Code No.	Dc	RPM (min-1)	Feed (mm/min)	RPM (min-1)	Feed (mm/min)	RPM (min-1)	Feed (mm/min)	RPM (min-1)	Feed (mm/min)	RPM (min-1)	Feed (mm/min)	RPM (min-1)	Feed (mm/min)	RPM (min-1)	Feed (mm/min)	RPM (min-1)	Feed (mm/min)
E141-4.0HX-1	1	23,850	180	23,850	180	18,750	158	14,813	135	14,250	64	14,813	135	23,850	180	5,325	38
E141-4.0HX-1.5	1.5	15,900	184	15,900	184	12,375	158	9,750	135	9,525	68	9,750	135	15,900	184	3,825	75
E141-4.0HX-2	2	11,925	184	11,925	184	9,315	158	7,388	135	7,163	68	7,388	135	11,925	184	3,000	90
E141-4.0HX-2.5	2.5	9,525	278	9,525	278	7,448	225	5,925	206	5,700	68	5,925	206	9,525	278	2,400	113
E141-4.0HX-3	3	7,950	512	7,950	512	6,210	398	4,913	291	4,800	79	4,913	291	7,950	512	2,400	135
E141-4.0HX-3.5	3.5	6,350	532	6,350	532	4,960	420	3,930	300	3,850	85	3,930	300	6,350	532	2,100	135
E141-4.0HX-4	4	4,763	551	4,763	551	3,713	443	2,963	310	2,850	90	2,963	310	4,763	551	1,800	135
E141-4.0HX-4.5	4.5	4,080	604	4,080	604	3,180	450	2,530	323	2,447	92	2,530	323	4,080	604	1,650	139
E141-4.0HX-5	5	3,412	656	3,412	656	2,663	469	2,100	336	2,047	94	2,100	336	3,412	656	1,500	143
E141-4.0HX-5.5	5.5	3,030	656	3,030	656	2,360	460	1,875	323	1,800	94	1,875	323	3,030	656	1,350	143
E141-4.0HX-6	6	2,655	656	2,655	656	2,070	450	1,650	310	1,575	94	1,650	310	2,655	656	1,200	143
E141-4.0HX-8	8	2,389	578	2,389	578	1,860	450	1,481	310	1,425	94	1,481	310	2,389	578	900	128
E141-4.0HX-10	10	2,738	578	2,738	578	1,553	446	1,234	281	1,196	90	1,234	281	2,738	578	750	120
E141-4.0HX-12	12	1,706	503	1,706	503	1,328	420	1,058	263	1,024	90	1,058	263	1,706	503	600	120
E141-4.0HX-16	16	1,493	503	1,493	503	1,163	390	923	234	893	75	923	234	1,493	503	450	113
E141-4.0HX-20	20	1,193	401	1,193	401	930	311	739	207	713	68	739	207	1,193	401	360	120
(mm)		ap:2.5D		ap:2.5D		ap:2.5D		ap:2.5D		ap:2.5D		ap:2.5D		ap:2.5D		ap:2.5D	
		ae:0.1D		ae:0.1D		ae:0.1D		ae:0.1D		ae:0.1D		ae:0.1D		ae:0.1D		ae:0.1D	

E141-5.0HX / Side Milling

Work Material		GR.1 Carbon Steel		GR.2 Low-alloyed Steel (~24HRC)		GR.3 Hi-alloyed Steel (~30HRC)		GR.4 Hardened Steel (30-38HRC)		GR.5 Hardened Steel (38-48HRC)		GR.8 Stainless Steel		GR.9 Cast Iron		GR.15 Titanium	
Vc m/min		60		60		40		33		30		33		60		16	
Code No.	Dc	RPM (min-1)	Feed (mm/min)	RPM (min-1)	Feed (mm/min)	RPM (min-1)	Feed (mm/min)	RPM (min-1)	Feed (mm/min)	RPM (min-1)	Feed (mm/min)	RPM (min-1)	Feed (mm/min)	RPM (min-1)	Feed (mm/min)	RPM (min-1)	Feed (mm/min)
E141-5.0HX-1	1	15,900	120	15,900	120	12,500	105	9,875	90	9,500	43	9,875	90	15,900	120	3,550	25
E141-5.0HX-1.5	1.5	10,600	123	10,600	123	8,250	105	6,500	90	6,350	45	6,500	90	10,600	123	2,550	50
E141-5.0HX-2	2	7,950	123	7,950	123	6,210	105	4,925	90	4,775	45	4,925	90	7,950	123	2,000	60
E141-5.0HX-2.5	2.5	6,350	185	6,350	185	4,965	150	3,950	138	3,800	45	3,950	138	6,350	185	1,600	75
E141-5.0HX-3	3	5,300	341	5,300	341	4,140	265	3,275	194	3,200	53	3,275	194	5,300	341	1,600	90
E141-5.0HX-3.5	3.5	4,230	354	4,230	354	3,300	280	2,620	200	2,550	56	2,620	200	4,230	354	1,400	90
E141-5.0HX-4	4	3,175	368	3,175	368	2,475	295	1,975	207	1,900	60	1,975	207	3,175	368	1,200	90
E141-5.0HX-4.5	4.5	2,720	400	2,720	400	2,120	305	1,680	215	1,630	60	1,680	215	2,720	400	1,100	90
E141-5.0HX-5	5	2,275	438	2,275	438	1,775	313	1,400	224	1,365	63	1,400	224	2,275	438	1,000	95
E141-5.0HX-5.5	5.5	2,020	438	2,020	438	1,570	306	1,250	215	1,200	63	1,250	215	2,020	438	900	95
E141-5.0HX-6	6	1,770	438	1,770	438	1,380	300	1,100	207	1,050	63	1,100	207	1,770	438	800	95
E141-5.0HX-8	8	1,592	385	1,592	385	1,240	300	987	207	950	63	987	207	1,592	385	600	85
E141-5.0HX-10	10	1,825	385	1,825	385	1,035	298	823	187	798	60	823	187	1,825	385	500	80
E141-5.0HX-12	12	1,137	335	1,137	335	885	280	705	175	682	60	705	175	1,137	335	400	80
E141-5.0HX-16	16	995	335	995	335	775	260	615	156	595	50	615	156	995	335	300	75
E141-5.0HX-20	20	795	268	795	268	620	208	493	138	475	45	493	138	795	268	240	80
(mm)		ap:3.0D		ap:3.0D		ap:3.0D		ap:3.0D		ap:3.0D		ap:3.0D		ap:3.0D		ap:3.0D	
		ae:0.05D		ae:0.05D		ae:0.05D		ae:0.05D		ae:0.05D		ae:0.05D		ae:0.05D		ae:0.05D	

1. Please work with good rigidity / high precision facilities and collet chuck.
2. Please choose proper cutting fluid.
3. The cutting data is reference value only. Please adjust it according to your real working conditions.
4. If RPM is lower the reference value, the Feed rate (fz) and RPM should be reduced by the same proportion.
5. If vibration occurs during cutting, please reduce cutting parameter.

E144X

Multipurpose End Mills

UMG
CarbideAlTiXN
X

Type of Operation



Code No. E144X-Dc

Dc 0 -0.02	Lc mm	L mm	d h6	AlTiXN E144X
1	3	50	4	●
1.5	5	50	4	●
2	6	50	4	●
2.5	8	50	4	●
3A	8	50	4	●
4A	11	50	4	●
3	8	50	6	●
3.5	10	50	6	●
4	11	50	6	●
4.5	11	50	6	●
5	13	50	6	●
5.5	13	50	6	●
6	16	50	6	●
7	20	60	8	●
8	20	60	8	●
9	25	72	10	●
10	25	72	10	●
11	30	75	12	●
12	30	75	12	●
14	40	100	16	●
16	45	100	16	●
20	50	110	20	●

Work Material

P	H	M	K	N	S
●	●	●	●	○	○

P	Steel
---	-------

H	<38HRC Hardened Steel
---	--------------------------

H	<48HRC Hardened Steel
---	--------------------------

M	Stainless Steel
---	-----------------

K	Cast Iron
---	-----------

S	Titanium
---	----------

S	Nickel
---	--------

S	High Temp Alloys
---	------------------

Feature of product:

Multipurpose End Mills for
Finishing- 4 Flutes

Effectively decrease the vibration
by various helix geometry and
unequal flutes designs.

Big chip breaker is designed
to reach high removal rate for
various work materials.

Obviously improving tool life with
Nano multilayer coating AlTiCrN.

Bigger helix design is for better
finishing machining.

Suitable for different kinds of
materials in finishing.

Side Milling

Work Material		GR.1 Carbon Steel		GR.2 Low-alloyed Steel (~24HRC)		GR.3 Hi-alloyed Steel (~30HRC)		GR.4 Hardened Steel (30~38HRC)		GR.5 Hardened Steel (38~48HRC)		GR.8 Stainless Steel		GR.9 Cast Iron	
Vc m/min		120		120		80		65		60		65		120	
Code No.	Dc	RPM (min-1)	Feed (mm/min)	RPM (min-1)	Feed (mm/min)	RPM (min-1)	Feed (mm/min)	RPM (min-1)	Feed (mm/min)	RPM (min-1)	Feed (mm/min)	RPM (min-1)	Feed (mm/min)	RPM (min-1)	Feed (mm/min)
E144X-1	1	31,800	240	31,800	240	25,000	210	19,750	180	19,000	85	19,750	180	31,800	240
E144X-1.5	1.5	21,200	245	21,200	245	16,500	210	13,000	180	12,700	90	13,000	180	21,200	245
E144X-2	2	15,900	245	15,900	245	12,420	210	9,850	180	9,550	90	9,850	180	15,900	245
E144X-2.5	2.5	12,700	370	12,700	370	9,930	300	7,900	275	7,600	90	7,900	275	12,700	370
E144X-3	3	10,600	683	10,600	683	8,280	530	6,550	389	6,400	105	6,550	389	10,600	683
E144X-4	4	6,350	735	6,350	735	4,950	590	3,950	413	3,800	120	3,950	413	6,350	735
E144X-5	5	4,550	875	4,550	875	3,550	625	2,800	448	2,730	125	2,800	448	4,550	875
E144X-6	6	3,540	875	3,540	875	2,760	600	2,200	413	2,100	125	2,200	413	3,540	875
E144X-8	8	3,185	770	3,185	770	2,480	600	1,975	413	1,900	125	1,975	413	3,185	770
E144X-10	10	3,650	770	3,650	770	2,070	595	1,645	375	1,595	120	1,645	375	3,650	770
E144X-12	12	2,275	670	2,275	670	1,770	560	1,410	350	1,365	120	1,410	350	2,275	670
E144X-14	14	2,130	670	2,130	670	1,660	540	1,320	331	1,277	110	1,320	330	2,130	670
E144X-16	16	1,990	670	1,990	670	1,550	520	1,230	312	1,190	100	1,230	312	1,990	670
E144X-20	20	1,590	535	1,590	535	1,240	415	985	277	950	90	985	277	1,590	535
(mm)		ap:1.5D		ap:1.5D		ap:1.5D		ap:1.5D		ap:1.5D		ap:1.5D		ap:1.5D	
		ae:0.2D		ae:0.2D		ae:0.2D		ae:0.2D		ae:0.1D		ae:0.2D		ae:0.2D	

Slotting

Work Material		GR.1 Carbon Steel		GR.2 Low-alloyed Steel (~24HRC)		GR.3 Hi-alloyed Steel (~30HRC)		GR.4 Hardened Steel (30~38HRC)		GR.5 Hardened Steel (38~48HRC)		GR.8 Stainless Steel		GR.9 Cast Iron	
Vc m/min		120		120		80		65		60		65		120	
Code No.	Dc	RPM (min-1)	Feed (mm/min)	RPM (min-1)	Feed (mm/min)	RPM (min-1)	Feed (mm/min)	RPM (min-1)	Feed (mm/min)	RPM (min-1)	Feed (mm/min)	RPM (min-1)	Feed (mm/min)	RPM (min-1)	Feed (mm/min)
E144X-1	1	31,800	200	31,800	200	25,000	180	19,750	150	19,000	85	19,750	150	31,800	200
E144X-1.5	1.5	21,200	200	21,200	200	16,500	180	13,000	150	12,700	90	13,000	150	21,200	200
E144X-2	2	15,900	220	15,900	220	12,420	180	9,850	150	9,550	90	9,850	150	15,900	220
E144X-2.5	2.5	12,700	330	12,700	330	9,930	220	7,900	175	7,600	90	7,900	175	12,700	330
E144X-3	3	10,600	600	10,600	600	8,280	430	6,550	290	6,400	105	6,550	290	10,600	600
E144X-4	4	6,350	635	6,350	635	4,950	500	3,950	325	3,800	120	3,950	325	6,350	635
E144X-5	5	4,550	775	4,550	775	3,550	525	2,800	348	2,730	125	2,800	348	4,550	775
E144X-6	6	3,540	775	3,540	775	2,760	500	2,200	313	2,100	125	2,200	313	3,540	775
E144X-8	8	3,185	650	3,185	650	2,480	500	1,975	313	1,900	125	1,975	313	3,185	650
E144X-10	10	3,650	670	3,650	670	2,070	490	1,645	288	1,595	120	1,645	288	3,650	670
E144X-12	12	2,275	560	2,275	560	1,770	460	1,410	275	1,365	120	1,410	275	2,275	560
E144X-14	14	2,130	610	2,130	610	1,660	440	1,320	255	1,277	110	1,320	255	2,130	610
E144X-16	16	1,990	660	1,990	660	1,550	420	1,230	240	1,190	100	1,230	240	1,990	660
E144X-20	20	1,590	500	1,590	500	1,240	360	985	200	950	90	985	200	1,590	500
(mm)		ap:0.5D		ap:0.5D		ap:0.5D		ap:0.5D		ap:0.05D		ap:0.5D		ap:0.5D	

1. Please work with good rigidity / high precision facilities and collet chuck.
2. Please choose proper cutting fluid.
3. The cutting data is reference value only. Please adjust it according to your real working conditions.
4. If RPM is lower the reference value, the Feed rate (fz) and RPM should be reduced by the same proportion.
5. If vibration occurs during cutting, please reduce cutting parameter.

E144-4.0X / 5.0X / 6.0X

Multipurpose End Mills

UMG
CarbideAITiXN
X

Type of Operation



Work Material

P	H	M	K	N	S
●	●	●	●	○	○

P	Steel
---	-------

H	<38HRC Hardened Steel
---	--------------------------

H	<48HRC Hardened Steel
---	--------------------------

M	Stainless Steel
---	-----------------

K	Cast Iron
---	-----------

S	Titanium
---	----------

S	Nickel
---	--------

S	High Temp Alloys
---	------------------

Feature of product:

Multipurpose End Mills for Finishing- 4 Flutes · Long Type
Effectively decrease the vibration by various helix geometry and unequal flutes designs.

Big chip breaker is designed to reach high removal rate for various work materials.

Obviously improving tool life with Nano multilayer coating AITiCrN.

Bigger helix design is for better finishing machining.

Suitable for different kinds of materials in finishing.

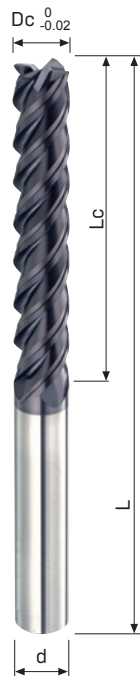

Code No. E144-4.0X-Dc

Dc	Lc	L	d	AITiXN
$\begin{matrix} 0 \\ -0.02 \end{matrix}$	mm	mm	h6	E144-4.0X
3	12	50	6	●
4	16	55	6	●
5	20	60	6	●
6	24	65	6	●
8	32	90	8	●
10	40	100	10	●
12	48	110	12	●
14	56	140	16	●
16	64	140	16	●
20	80	160	20	●

Code No. E144-5.0X-Dc

Dc	Lc	L	d	AITiXN
$\begin{matrix} 0 \\ -0.02 \end{matrix}$	mm	mm	h6	E144-5.0X
3	15	55	6	●
4	20	60	6	●
5	25	65	6	●
6	30	75	6	●
8	40	90	8	●
10	50	100	10	●
12	60	110	12	●
14	70	140	16	●
16	80	160	16	●
20	100	200	20	●

Code No. E144-6.0X-Dc

Dc	Lc	L	d	AITiXN
$\begin{matrix} 0 \\ -0.02 \end{matrix}$	mm	mm	h6	E144-6.0X
3	18	70	6	●
4	24	70	6	●
5	30	80	6	●
6	36	80	6	●
8	48	100	8	●
10	60	110	10	●
12	72	120	12	●
16	96	160	16	●
20	120	200	20	●

E141-4.OX / Side Milling

Work Material		GR.1 Carbon Steel		GR.2 Low-alloyed Steel (~24HRC)		GR.3 Hi-alloyed Steel (~30HRC)		GR.4 Hardened Steel (30~38HRC)		GR.5 Hardened Steel (38~48HRC)		GR.8 Stainless Steel	
Vc m/min		100~120		100~120		100~120		65~80		55~70		55~70	
Code No.	Dc	RPM (min-1)	Feed (mm/min)	RPM (min-1)	Feed (mm/min)	RPM (min-1)	Feed (mm/min)	RPM (min-1)	Feed (mm/min)	RPM (min-1)	Feed (mm/min)	RPM (min-1)	Feed (mm/min)
E144-4.OX-3	3	11,000	618	11,000	618	11,000	618	8,500	285	5,900	199	6,800	228
E144-4.OX-4	4	8,300	659	8,300	659	8,300	659	6,400	304	4,500	213	5,100	243
E144-4.OX-5	5	6,600	669	6,600	669	6,600	669	5,100	323	3,600	227	4,100	258
E144-4.OX-6	6	5,500	680	5,500	680	5,500	680	4,200	342	3,000	239	3,400	265
E144-4.OX-8	8	4,200	699	4,200	699	4,200	699	3,200	355	2,200	241	2,600	284
E144-4.OX-10	10	3,300	689	3,300	689	3,300	689	2,600	366	1,800	240	2,000	282
E144-4.OX-12	12	2,800	633	2,800	633	2,800	633	2,200	337	1,500	220	1,700	271
E144-4.OX-14	14	2,400	538	2,400	538	2,400	538	1,800	283	1,300	194	1,400	222
E144-4.OX-16	16	2,100	466	2,100	466	2,100	466	1,600	269	1,100	188	1,300	219
E144-4.OX-20	20	1,660	454	1,660	454	1,660	454	1,270	256	890	172	1,020	201
(mm) 		ap:3.0D		ap:3.0D		ap:3.0D		ap:3.0D		ap:3.0D		ap:3.0D	
		ae:0.05D		ae:0.05D		ae:0.05D		ae:0.05D		ae:0.05D		ae:0.05D	

E141-5.OX / Side Milling

Work Material		GR.1 Carbon Steel		GR.2 Low-alloyed Steel (~24HRC)		GR.3 Hi-alloyed Steel (~30HRC)		GR.4 Hardened Steel (30~38HRC)		GR.5 Hardened Steel (38~48HRC)		GR.8 Stainless Steel	
Vc m/min		100~120		100~120		100~120		65~80		55~70		55~70	
Code No.	Dc	RPM (min-1)	Feed (mm/min)	RPM (min-1)	Feed (mm/min)	RPM (min-1)	Feed (mm/min)	RPM (min-1)	Feed (mm/min)	RPM (min-1)	Feed (mm/min)	RPM (min-1)	Feed (mm/min)
E144-5.OX-3	3	9,700	464	9,700	464	9,700	464	7,400	214	5,200	149	6,000	171
E144-5.OX-4	4	7,300	494	7,300	494	7,300	494	5,600	228	3,900	160	4,500	183
E144-5.OX-5	5	5,800	502	5,800	502	5,800	502	4,500	243	3,200	171	3,600	193
E144-5.OX-6	6	4,800	510	4,800	510	4,800	510	3,700	256	2,600	179	2,900	199
E144-5.OX-8	8	3,600	524	3,600	524	3,600	524	2,800	266	2,000	181	2,200	213
E144-5.OX-10	10	2,900	217	2,900	217	2,900	217	2,200	274	1,500	180	1,800	212
E144-5.OX-12	12	2,500	475	2,500	475	2,500	475	1,900	253	1,300	165	1,500	203
E144-5.OX-16	16	1,800	349	1,800	349	1,800	349	1,400	202	1,000	141	1,100	165
E144-5.OX-20	20	1,450	341	1,450	341	1,450	341	1,110	192	780	129	890	151
(mm) 		ap:3.0D		ap:3.0D		ap:3.0D		ap:3.0D		ap:3.0D		ap:3.0D	
		ae:0.05D		ae:0.05D		ae:0.05D		ae:0.05D		ae:0.05D		ae:0.05D	

E141-6.OX / Side Milling

Work Material		GR.1 Carbon Steel		GR.2 Low-alloyed Steel (~24HRC)		GR.3 Hi-alloyed Steel (~30HRC)		GR.4 Hardened Steel (30~38HRC)		GR.5 Hardened Steel (38~48HRC)		GR.8 Stainless Steel	
Vc m/min		100~120		100~120		100~120		65~80		55~70		55~70	
Code No.	Dc	RPM (min-1)	Feed (mm/min)	RPM (min-1)	Feed (mm/min)	RPM (min-1)	Feed (mm/min)	RPM (min-1)	Feed (mm/min)	RPM (min-1)	Feed (mm/min)	RPM (min-1)	Feed (mm/min)
E144-6.OX-3	3	9,700	386	9,700	386	9,700	386	7,400	178	5,200	124	6,000	143
E144-6.OX-4	4	7,300	412	7,300	412	7,300	412	5,600	190	3,900	133	4,500	152
E144-6.OX-5	5	5,800	418	5,800	418	5,800	418	4,500	202	3,200	142	3,600	161
E144-6.OX-6	6	4,800	425	4,800	425	4,800	425	3,700	214	2,600	149	2,900	166
E144-6.OX-8	8	3,600	437	3,600	437	3,600	437	2,800	222	2,000	151	2,200	177
E144-6.OX-10	10	2,900	431	2,900	431	2,900	431	2,200	228	1,500	150	1,800	176
E144-6.OX-12	12	2,500	395	2,500	395	2,500	395	1,900	211	1,300	137	1,500	169
E144-6.OX-16	16	1,800	291	1,800	291	1,800	291	1,400	168	1,000	118	1,100	137
E144-6.OX-20	20	1,450	284	1,450	284	1,450	284	1,110	160	780	107	890	126
(mm) 		ap:3.0D		ap:3.0D		ap:3.0D		ap:3.0D		ap:3.0D		ap:3.0D	
		ae:0.03D		ae:0.03D		ae:0.03D		ae:0.03D		ae:0.03D		ae:0.03D	

B252-2.5HX

Multipurpose End Mills With Corner Radius

UMG
Carbide

AlTiCrN
HX



Type of Operation



Work Material

P	H	M	K	N	S
●	●	●	●	●	●

P Steel

H <38HRC
Hardened Steel

H <48HRC
Hardened Steel

H <56HRC
Hardened Steel

M Stainless Steel

K Cast Iron

S Titanium

S Nickel

S High Temp Alloys

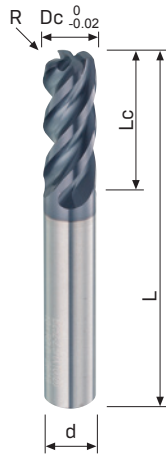

						Code No. B252-2.5HX-Dc×R					
Dc	R	Lc	L	d	AlTiCrN	Dc	R	Lc	L	d	AlTiCrN
$0_{-0.02}^0$	± 0.01	mm	mm	h6	B252-2.5HX	$0_{-0.02}^0$	± 0.01	mm	mm	h6	B252-2.5HX
1	R0.1	2.5	50	4	●	7	R0.5	17.5	60	8	●
1	R0.2	2.5	50	4	●	7	R1	17.5	60	8	●
1	R0.3	2.5	50	4	●	7	R1.2	17.5	60	8	●
1.5	R0.1	3.75	50	4	●	7	R1.5	17.5	60	8	●
1.5	R0.2	3.75	50	4	●	7	R1.6	17.5	60	8	●
1.5	R0.3	3.75	50	4	●	7	R1.8	17.5	60	8	●
2	R0.1	5	50	4	●	7	R2	17.5	60	8	●
2	R0.2	5	50	4	●	7	R3	17.5	60	8	●
2	R0.3	5	50	4	●	8	R0.2	20	60	8	●
2	R0.5	5	50	4	●	8	R0.3	20	60	8	●
2.5	R0.1	6.25	50	4	●	8	R0.4	20	60	8	●
2.5	R0.2	6.25	50	4	●	8	R0.5	20	60	8	●
2.5	R0.3	6.25	50	4	●	8	R0.8	20	60	8	●
2.5	R0.5	6.25	50	4	●	8	R1	20	60	8	●
3	R0.1	7.5	50	6	●	8	R1.2	20	60	8	●
3	R0.2	7.5	50	6	●	8	R1.5	20	60	8	●
3	R0.3	7.5	50	6	●	8	R1.6	20	60	8	●
3	R0.4	7.5	50	6	●	8	R1.8	20	60	8	●
3	R0.5	7.5	50	6	●	8	R2	20	60	8	●
4	R0.1	10	50	6	●	8	R3	20	60	8	●
4	R0.2	10	50	6	●	9	R0.2	22.5	72	10	●
4	R0.3	10	50	6	●	9	R0.3	22.5	72	10	●
4	R0.4	10	50	6	●	9	R0.4	22.5	72	10	●
4	R0.5	10	50	6	●	9	R0.5	22.5	72	10	●
4	R1	10	50	6	●	9	R1	22.5	72	10	●
5	R0.2	12.5	50	6	●	9	R1.2	22.5	72	10	●
5	R0.3	12.5	50	6	●	9	R1.5	22.5	72	10	●
5	R0.4	12.5	50	6	●	9	R1.6	22.5	72	10	●
5	R0.5	12.5	50	6	●	9	R1.8	22.5	72	10	●
5	R1	12.5	50	6	●	9	R2	22.5	72	10	●
6	R0.2	15	50	6	●	9	R3	22.5	72	10	●
6	R0.3	15	50	6	●	10	R0.2	25	72	10	●
6	R0.4	15	50	6	●	10	R0.3	25	72	10	●
6	R0.5	15	50	6	●	10	R0.4	25	72	10	●
6	R0.8	15	50	6	●	10	R0.5	25	72	10	●
6	R1	15	50	6	●	10	R0.8	25	72	10	●
6	R1.2	15	50	6	●	10	R1	25	72	10	●
6	R1.5	15	50	6	●	10	R1.2	25	72	10	●
6	R1.6	15	50	6	●	10	R1.5	25	72	10	●
6	R1.8	15	50	6	●	10	R1.6	25	72	10	●
6	R2	15	50	6	●	10	R1.8	25	72	10	●
7	R0.2	17.5	60	8	●	10	R2	25	72	10	●
7	R0.3	17.5	60	8	●	10	R3	25	72	10	●
7	R0.4	17.5	60	8	●						

Feature of product:

Multipurpose End Mills with
Corner Radius- 4 Flutes

Using UMG carbide material and
Nano multilayer coating AlTiCrN
enable to enhance lubrication and
wear resistance.

Effectively decrease the vibration
by various helix geometry and
unequal flutes designs.

Big chip breaker is designed
to reach high removal rate for
various work materials.

Cutting edge with corner radius
desgin to increase tool life.

Suitable for various kinds of
work materials from the end of
roughing to finishing.

Side Milling

Work Material		GR.1 Carbon Steel GR.2 Low-alloyed Steel (~24HRC)		GR.3 Hi-alloyed Steel (~30HRC)		GR.4 Hardened Steel (30~38HRC)		GR.5 Hardened Steel (38~48HRC)		GR.6 Hardened Steel (48~56HRC)		GR.8 Stainless Stell		GR.9 Cast Iron		GR.15 Titanium	
Vc m/min		Ø1.0~2.5 60~80 Ø3.0~20 80~85		Ø1.0~2.5 47~70 Ø3.0~20 70~75		Ø1.0~1.5 47~57 Ø1.5~20 57~70		Ø1.0~2.5 30~47 Ø3.0~20 50~60		Ø1.0~2.5 30~47 Ø3.0~20 50~60		Ø1.0~2.5 75~80 Ø3.0~20 80~85		Ø1.0~2.5 60~80 Ø3.0~20 80~85		Ø1.0~2.5 15~25 Ø3.0~20 25~35	
Code No.	Dc	RPM (min-1)	Feed (mm/min)	RPM (min-1)	Feed (mm/min)	RPM (min-1)	Feed (mm/min)	RPM (min-1)	Feed (mm/min)	RPM (min-1)	Feed (mm/min)	RPM (min-1)	Feed (mm/min)	RPM (min-1)	Feed (mm/min)	RPM (min-1)	Feed (mm/min)
B252-2.5HX-1	1	20,000	240	15,000	215	15,000	215	10,000	85	7,100	40	25,000	350	20,000	240	7,100	50
B252-2.5HX-1.5	1.5	13,500	245	12,000	215	12,000	215	8,000	90	5,100	50	16,500	375	13,500	245	5,100	100
B252-2.5HX-2	2	13,000	300	11,000	280	11,000	280	7,000	110	3,900	60	12,500	390	13,000	300	4,000	120
B252-2.5HX-2.5	2.5	10,000	320	9,000	300	9,000	300	6,000	120	3,000	60	10,000	400	10,000	320	3,200	150
B252-2.5HX-3	3	8,800	500	7,200	350	7,200	350	5,300	125	2,700	60	8,500	400	8,800	500	3,200	180
B252-2.5HX-4	4	6,600	530	5,500	360	5,500	360	4,200	130	2,200	70	6,500	440	6,600	530	2,400	180
B252-2.5HX-5	5	5,300	600	4,350	420	4,350	420	3,500	140	1,900	75	5,200	460	5,300	600	2,000	190
B252-2.5HX-6	6	4,500	610	3,700	425	3,700	425	2,900	145	1,500	70	4,300	460	4,500	610	1,600	190
B252-2.5HX-7	7	3,800	600	3,200	425	3,200	425	2,500	145	1,200	70	3,650	460	3,800	600	1,400	180
B252-2.5HX-8	8	3,300	590	2,700	425	2,700	425	2,200	145	1,100	65	3,200	460	3,300	590	1,200	170
B252-2.5HX-9	9	2,900	590	2,500	425	2,500	425	2,000	145	1,000	65	2,850	460	2,900	590	1,100	165
B252-2.5HX-10	10	2,600	580	2,200	420	2,200	420	1,700	145	950	65	2,600	460	2,600	580	1,000	160
(mm)		ap:1.5D		ap:1.5D		ap:1.5D		ap:1.5D		ap:1.5D		ap:1.0D		ap:1.5D		ap:1.0	
		ae: < 3 0.05D ≥ 3 0.1D		ae: < 3 0.05D ≥ 3 0.1D		ae: < 3 0.05D ≥ 3 0.1D		ae: < 3 0.05D ≥ 3 0.1D		ae:0.02D		ae:0.05D		ae: < 3 0.05D ≥ 3 0.1D		ae: < 3 0.05D ≥ 3 0.1D	

1. Please work with good rigidity / high precision facilities and collet chuck.
2. Please choose proper cutting fluid.
3. The cutting data is reference value only. Please adjust it according to your real working conditions.
4. If RPM is lower the reference value, the Feed rate (fz) and RPM should be reduced by the same proportion.
5. If vibration occurs during cutting, please reduce cutting parameter.

B252-2.5HX

Multipurpose End Mills With Corner Radius

UMG
Carbide



Type of Operation



Work Material

P	H	M	K	N	S
●	●	●	●	●	●

P Steel

H <38HRC
Hardened Steel

H <48HRC
Hardened Steel

H <56HRC
Hardened Steel

M Stainless Steel

K Cast Iron

S Titanium

S Nickel

S High Temp Alloys

Feature of product:

Multipurpose End Mills with
Corner Radius- 4 Flutes

Using UMG carbide material and
Nano multilayer coating AlTiCrN
enable to enhance lubrication and
wear resistance.

Effectively decrease the vibration
by various helix geometry and
unequal flutes designs.

Big chip breaker is designed
to reach high removal rate for
various work materials.

Cutting edge with corner radius
desgin to increase tool life.

Suitable for various kinds of
work materials from the end of
roughing to finishing.

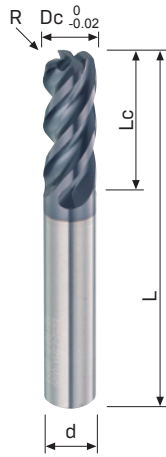

Code No. B252-2.5HX-Dc×R

Dc	R	Lc	L	d	AlTiCrN	Dc	R	Lc	L	d	AlTiCrN
$0_{-0.02}$	± 0.01	mm	mm	h6	B252-2.5HX	$0_{-0.02}$	± 0.01	mm	mm	h6	B252-2.5HX
11	R0.2	27.5	75	12	●	16	R4	40	100	16	●
11	R0.3	27.5	75	12	●	17	R0.5	42.5	100	20	●
11	R0.4	27.5	75	12	●	17	R1	42.5	100	20	●
11	R0.5	27.5	75	12	●	17	R1.5	42.5	100	20	●
11	R1	27.5	75	12	●	17	R2	42.5	100	20	●
11	R1.2	27.5	75	12	●	17	R3	42.5	100	20	●
11	R1.5	27.5	75	12	●	18	R0.5	45	100	20	●
11	R1.6	27.5	75	12	●	18	R1	45	100	20	●
11	R1.8	27.5	75	12	●	18	R1.5	45	100	20	●
11	R2	27.5	75	12	●	18	R2	45	100	20	●
11	R3	27.5	75	12	●	18	R3	45	100	20	●
12	R0.2	30	75	12	●	19	R0.5	47.5	100	20	●
12	R0.3	30	75	12	●	19	R1	47.5	100	20	●
12	R0.4	30	75	12	●	19	R1.5	47.5	100	20	●
12	R0.5	30	75	12	●	19	R2	47.5	100	20	●
12	R0.8	30	75	12	●	19	R3	47.5	100	20	●
12	R1	30	75	12	●	20	R0.5	50	100	20	●
12	R1.2	30	75	12	●	20	R1	50	100	20	●
12	R1.5	30	75	12	●	20	R1.5	50	100	20	●
12	R1.6	30	75	12	●	20	R2	50	100	20	●
12	R1.8	30	75	12	●	20	R3	50	100	20	●
12	R2	30	75	12	●	20	R4	50	100	20	●
12	R3	30	75	12	●	20	R5	50	100	20	●
12	R4	30	75	12	●						
13	R0.5	32.5	100	16	●						
13	R1	32.5	100	16	●						
13	R1.5	32.5	100	16	●						
13	R2	32.5	100	16	●						
13	R3	32.5	100	16	●						
14	R0.5	35	100	16	●						
14	R1	35	100	16	●						
14	R1.5	35	100	16	●						
14	R2	35	100	16	●						
14	R3	35	100	16	●						
15	R0.5	37.5	100	16	●						
15	R1	37.5	100	16	●						
15	R1.5	37.5	100	16	●						
15	R2	37.5	100	16	●						
15	R3	37.5	100	16	●						
16	R0.5	40	100	16	●						
16	R1	40	100	16	●						
16	R1.5	40	100	16	●						
16	R2	40	100	16	●						
16	R3	40	100	16	●						

Side Milling

Work Material		GR.1 Carbon Steel GR.2 Low-alloyed Steel (~24HRC)		GR.3 Hi-alloyed Steel (~30HRC)		GR.4 Hardened Steel (30~38HRC)		GR.5 Hardened Steel (38~48HRC)		GR.6 Hardened Steel (48~56HRC)		GR.8 Stainless Stell		GR.9 Cast Iron		GR.15 Titanium		
Vc m/min		Ø1.0~2.5 60~80 Ø3.0~20 80~85		Ø1.0~2.5 47~70 Ø3.0~20 70~75		Ø1.0~1.5 47~57 Ø1.5~20 57~70		Ø1.0~2.5 30~47 Ø3.0~20 50~60		Ø1.0~2.5 30~47 Ø3.0~20 50~60		Ø1.0~2.5 75~80 Ø3.0~20 80~85		Ø1.0~2.5 60~80 Ø3.0~20 80~85		Ø1.0~2.5 15~25 Ø3.0~20 25~35		
Code No.	Dc	RPM (min-1)	Feed (mm/min)	RPM (min-1)	Feed (mm/min)	RPM (min-1)	Feed (mm/min)	RPM (min-1)	Feed (mm/min)	RPM (min-1)	Feed (mm/min)	RPM (min-1)	Feed (mm/min)	RPM (min-1)	Feed (mm/min)	RPM (min-1)	Feed (mm/min)	
B252-2.5HX-11	11	2,400	580	2,000	420	2,000	420	1,600	140	850	60	2,350	440	2,400	580	900	160	
B252-2.5HX-12	12	2,200	580	1,800	420	1,800	420	1,400	140	800	60	2,150	410	2,200	580	800	160	
B252-2.5HX-13	13	2,000	560	1,700	410	1,700	410	1,350	140	700	55	2,000	400	2,000	570	750	160	
B252-2.5HX-14	14	1,900	550	1,600	410	1,600	410	1,250	130	650	55	1,820	400	1,850	560	700	160	
B252-2.5HX-15	15	1,700	540	1,500	400	1,500	400	1,250	130	600	50	1,700	400	1,700	540	650	150	
B252-2.5HX-16	16	1,600	530	1,300	400	1,300	400	1,200	130	600	45	1,600	390	1,600	530	600	150	
B252-2.5HX-17	17	1,500	520	1,250	390	1,250	390	1,100	120	550	45	1,500	390	1,500	530	550	150	
B252-2.5HX-18	18	1,450	520	1,200	390	1,200	390	1,000	120	520	40	1,450	380	1,450	520	500	150	
B252-2.5HX-19	19	1,350	520	1,150	380	1,150	380	950	115	500	40	1,350	380	1,400	510	530	150	
B252-2.5HX-20	20	1,300	510	1,100	370	1,100	370	890	110	470	35	1,300	370	1,300	510	480	140	
	ap:1.5D		ap:1.5D		ap:1.5D		ap:1.5D		ap:1.5D		ap:1.5D		ap:1.0D		ap:1.5D		ap:1.0	
	ae: < 3 0.05D ≥ 3 0.1D		ae: < 3 0.05D ≥ 3 0.1D		ae: < 3 0.05D ≥ 3 0.1D		ae: < 3 0.05D ≥ 3 0.1D		ae: < 3 0.05D ≥ 3 0.1D		ae:0.02D		ae:0.05D		ae: < 3 0.05D ≥ 3 0.1D		ae: < 3 0.05D ≥ 3 0.1D	

1. Please work with good rigidity / high precision facilities and collet chuck.
2. Please choose proper cutting fluid.
3. The cutting data is reference value only. Please adjust it according to your real working conditions.
4. If RPM is lower the reference value, the Feed rate [fz] and RPM should be reduced by the same proportion.
5. If vibration occurs during cutting, please reduce cutting parameter.

B274HX

Multipurpose End Mills With Corner Radius

UMG Carbide

AlTiCrN HX



Type of Operation



Work Material

P	H	M	K	N	S
●	●	●	●	●	●

P Steel

H <38HRC Hardened Steel

H <48HRC Hardened Steel

H <56HRC Hardened Steel

M Stainless Steel

K Cast Iron

S Titanium

S Nickel

S High Temp Alloys

Feature of product:

Multipurpose End Mills with Corner Radius- 4 Flutes · Short Type · Long Neck

Using UMG carbide material and Nano multilayer coating AlTiCrN enable to enhance lubrication and wear resistance.

Effectively decrease the vibration by various helix geometry and unequal flutes designs.

Big chip breaker is designed to reach high removal rate for various work materials.

Designed with step to increase the effective length.

Cutting edge with corner radius design to increase tool life.

Suitable for different kinds of materials cutting.

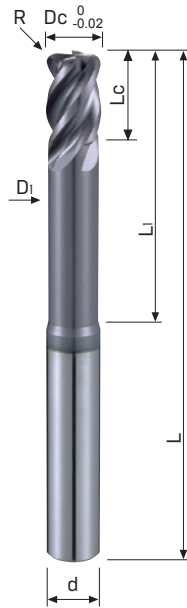

Code No. B274HX-Dc×R

Dc 0 -0.02	R ±0.01	Lc mm	L mm	d h6	L1 mm	D1 mm	AlTiCrN B274HX
1	0.1	1.5	60	6	5	0.95	●
1	0.2	1.5	60	6	5	0.95	●
1.5	0.1	2.3	60	6	7.5	1.45	●
1.5	0.2	2.3	60	6	7.5	1.45	●
2	0.1	3	60	6	10	1.95	●
2	0.2	3	60	6	10	1.95	●
2	0.5	3	60	6	10	1.95	●
2.5	0.1	3.8	60	6	12.5	2.4	●
2.5	0.2	3.8	60	6	12.5	2.4	●
2.5	0.5	3.8	60	6	12.5	2.4	●
3	0.1	4.5	70	6	15	2.8	●
3	0.2	4.5	70	6	15	2.8	●
3	0.5	4.5	70	6	15	2.8	●
4	0.1	6	70	6	20	3.7	●
4	0.2	6	70	6	20	3.7	●
4	0.5	6	70	6	20	3.7	●
4	1	6	70	6	20	3.7	●
5	0.2	7.5	70	6	25	4.6	●
5	0.5	7.5	70	6	25	4.6	●
5	1	7.5	70	6	25	4.6	●
6	0.2	9	70	6	30	5.5	●
6	0.3	9	70	6	30	5.5	●
6	0.5	9	70	6	30	5.5	●
6	1	9	70	6	30	5.5	●
6	1.5	9	70	6	30	5.5	●
6	2	9	70	6	30	5.5	●
8	0.2	12	80	8	40	7.4	●
8	0.3	12	80	8	40	7.4	●
8	0.5	12	80	8	40	7.4	●
8	1	12	80	8	40	7.4	●
8	1.5	12	80	8	40	7.4	●
8	2	12	80	8	40	7.4	●
8	3	12	80	8	40	7.4	●
10	0.2	15	95	10	50	9.2	●
10	0.3	15	95	10	50	9.2	●
10	0.5	15	95	10	50	9.2	●
10	1	15	95	10	50	9.2	●
10	1.5	15	95	10	50	9.2	●
10	2	15	95	10	50	9.2	●
10	3	15	95	10	50	9.2	●
12	0.2	18	110	12	60	11	●
12	0.3	18	110	12	60	11	●
12	0.5	18	110	12	60	11	●
12	1	18	110	12	60	11	●
12	1.5	18	110	12	60	11	●
12	2	18	110	12	60	11	●
12	3	18	110	12	60	11	●
16	0.5	24	140	16	80	14.5	●
16	1	24	140	16	80	14.5	●
16	1.5	24	140	16	80	14.5	●
16	2	24	140	16	80	14.5	●
16	3	24	140	16	80	14.5	●
20	0.5	30	160	20	100	18.2	●
20	1	30	160	20	100	18.2	●
20	1.5	30	160	20	100	18.2	●
20	2	30	160	20	100	18.2	●
20	3	30	160	20	100	18.2	●
20	5	30	160	20	100	18.2	●

Side Milling

Work Material		GR.1 Carbon Steel		GR.2 Low-alloyed Steel (~24HRC)		GR.3 Hi-alloyed Steel (~30HRC)		GR.4 Hardened Steel (30~38HRC)		GR.5 Hardened Steel (38~48HRC)		GR.6 Hardened Steel (48~56HRC)		GR.8 Stainless Steel		GR.9 Cast Iron		GR.15 Titanium	
Vc m/min		Ø1.0~2.5 60~80 Ø3.0~20 80~85		Ø1.0~2.5 60~80 Ø3.0~20 80~85		Ø1.0~2.5 47~70 Ø3.0~20 70~75		Ø1.0~1.5 47~57 Ø1.5~20 57~70		Ø1.0~2.5 30~47 Ø3.0~20 50~60		Ø1.0~20 22~30		Ø1.0~2.5 55~65 Ø3.0~20 60~70		Ø1.0~2.5 60~80 Ø3.0~20 80~85		Ø1.0~2.5 30~35 Ø3.0~0 35~40	
Code No.	Dc	RPM (min-1)	Feed (mm/min)	RPM (min-1)	Feed (mm/min)	RPM (min-1)	Feed (mm/min)	RPM (min-1)	Feed (mm/min)	RPM (min-1)	Feed (mm/min)	RPM (min-1)	Feed (mm/min)	RPM (min-1)	Feed (mm/min)	RPM (min-1)	Feed (mm/min)	RPM (min-1)	Feed (mm/min)
B274HX-1	1	20,000	240	20,000	240	15,000	215	15,000	215	10,000	85	7,100	40	17,500	250	20,000	240	9,550	136
B274HX-1.5	1.5	13,500	245	13,500	245	12,000	215	12,000	215	8,000	90	5,100	50	11,600	250	13,500	245	6,366	115
B274HX-2	2	13,000	300	13,000	300	11,000	280	11,000	280	7,000	110	3,900	60	8,750	263	13,000	300	4,775	122
B274HX-2.5	2.5	10,000	320	10,000	320	9,000	300	9,000	300	6,000	120	3,000	60	7,000	275	10,000	320	3,820	127
B274HX-3	3	8,800	500	8,800	500	7,200	350	7,200	350	5,300	125	2,700	60	6,370	361	8,800	500	3,714	181
B274HX-4	4	6,600	530	6,600	530	5,500	360	5,500	360	4,200	130	2,200	70	4,770	365	6,600	530	2,785	182
B274HX-5	5	5,300	600	5,300	600	4,350	420	4,350	420	3,500	140	1,900	75	3,800	430	5,300	600	2,228	215
B274HX-6	6	4,500	610	4,500	610	3,700	425	3,700	425	2,900	145	1,500	70	3,185	426	4,500	610	1,857	213
B274HX-8	8	3,300	590	3,300	590	2,700	425	2,700	425	2,200	145	1,100	65	2,390	438	3,300	590	1,392	219
B274HX-10	10	2,600	580	2,600	580	2,200	420	2,200	420	1,700	145	950	65	1,910	425	2,600	580	1,114	213
B274HX-12	12	2,200	580	2,200	580	1,800	420	1,800	420	1,400	140	800	60	1,590	433	2,200	580	928	216
B274HX-16	16	1,600	530	1,600	530	1,300	400	1,300	400	1,200	130	600	45	1,195	428	1,600	530	696	214
B274HX-20	20	1,300	510	1,300	510	1,100	370	1,100	370	890	110	470	35	955	374	1,300	510	557	187
		ap:1.0D		ap:1.0D		ap:1.0D		ap:1.0D		ap:1.0D		ap:1.0D		ap:1.0D		ap:1.0D		ap:1.0D	
		ae:0.05D		ae:0.05D		ae:0.05D		ae:0.05D		ae:0.05D		ae:0.02D		ae:0.05D		ae:0.05D		ae:0.05D	

High feed cutting

Work Material		GR.1 Carbon Steel		GR.2 Low-alloyed Steel (~24HRC)		GR.3 Hi-alloyed Steel (~30HRC)		GR.4 Hardened Steel (30~38HRC)		GR.5 Hardened Steel (38~48HRC)		GR.6 Hardened Steel (48~56HRC)		GR.8 Stainless Steel		GR.9 Cast Iron		GR.15 Titanium	
Vc m/min		Ø1.0~2.5 60~80 Ø3.0~20 80~85		Ø1.0~2.5 60~80 Ø3.0~20 80~85		Ø1.0~2.5 47~70 Ø3.0~20 70~75		Ø1.0~1.5 47~57 Ø1.5~20 57~70		Ø1.0~2.5 30~47 Ø3.0~20 50~60		Ø1.0~20 22~30		Ø1.0~2.5 80~100 Ø3.0~20 130~150		Ø1.0~2.5 60~80 Ø3.0~20 80~85		Ø1.0~2.5 60~80 Ø3~20 80~85	
Code No.	Dc	RPM (min-1)	Feed (mm/min)	RPM (min-1)	Feed (mm/min)	RPM (min-1)	Feed (mm/min)	RPM (min-1)	Feed (mm/min)	RPM (min-1)	Feed (mm/min)	RPM (min-1)	Feed (mm/min)	RPM (min-1)	Feed (mm/min)	RPM (min-1)	Feed (mm/min)	RPM (min-1)	Feed (mm/min)
B274HX-1	1	32,000	1,280	32,000	1,280	26,000	1,040	26,000	1,040	20,000	800	20,000	800	25,400	1,016	32,000	1,280	19,100	760
B274HX-1.5	1.5	22,000	1,760	22,000	1,760	17,000	1,360	17,000	1,360	13,000	1,040	13,000	1,040	16,800	1,344	22,000	1,760	12,732	1,018
B274HX-2	2	16,000	1,920	16,000	1,920	14,000	1,680	14,000	1,680	10,000	1,200	10,000	1,200	12,700	1,524	16,000	1,920	9,550	1,146
B274HX-2.5	2.5	14,000	2,240	14,000	2,240	12,000	1,920	12,000	1,920	9,000	1,440	9,000	1,440	10,185	1,629	14,000	2,240	7,640	1,222
B274HX-3	3	13,000	2,600	13,000	2,600	10,500	2,100	10,500	2,100	8,500	1,700	8,500	1,700	13,793	2,758	13,000	2,600	8,488	1,698
B274HX-4	4	12,000	2,880	12,000	2,880	10,000	2,400	10,000	2,400	8,500	2,040	8,500	2,040	10,345	2,482	12,000	2,880	6,366	1,528
B274HX-5	5	9,500	2,660	9,500	2,660	8,500	2,380	8,500	2,380	7,000	1,960	7,000	1,960	8,276	2,317	9,500	2,660	5,093	1,426
B274HX-6	6	8,000	2,560	8,000	2,560	7,500	2,400	7,500	2,400	6,500	2,080	6,500	2,080	6,897	2,207	8,000	2,560	4,244	1,358
B274HX-8	8	6,500	2,340	6,500	2,340	5,500	1,980	5,500	1,980	5,500	1,760	5,500	1,760	5,173	1,862	6,500	2,340	3,183	1,145
B274HX-10	10	5,500	2,200	5,500	2,200	4,800	1,920	4,800	1,920	4,000	1,440	4,000	1,440	4,138	1,655	5,500	2,200	2,546	1,018
B274HX-12	12	5,000	2,200	5,000	2,200	4,000	1,760	4,000	1,760	3,500	1,400	3,500	1,400	3,448	1,517	5,000	2,200	2,122	934
B274HX-16	16	4,000	1,920	4,000	1,920	3,000	1,440	3,000	1,440	2,500	1,000	2,500	1,000	2,586	1,241	4,000	1,920	1,592	764
B274HX-20	20	3,000	1,560	3,000	1,560	2,400	1,248	2,400	1,248	2,000	800	2,000	800	2,069	1,075	3,000	1,560	1,273	662
		ap:0.3×R		ap:0.3×R		ap:0.3×R		ap:0.3×R		ap:0.2×R		ap:0.1×R		ap:0.3×R		ap:0.3×R		ap:0.3×R	
		ae:0.3×D		ae:0.3×D		ae:0.3×D		ae:0.3×D		ae:0.3×D		ae:0.3×D		ae:0.3×D		ae:0.3×D		ae:0.3×D	

1. Please work with good rigidity / high precision facilities and collet chuck.
2. Please choose proper cutting fluid.
3. The cutting data is reference value only. Please adjust it according to your real working conditions.
4. If RPM is lower the reference value, the Feed rate (fz) and RPM should be reduced by the same proportion.
5. If vibration occurs during cutting, please reduce cutting parameter.

F612HX / F617HX

Multipurpose End Mills

UMG Carbide



Type of Operation



Work Material

P	H	M	K	N	S
●	●	●	●	○	○

P	Steel
----------	-------

H	<38HRC Hardened Steel
----------	--------------------------

H	<48HRC Hardened Steel
----------	--------------------------

M	Stainless Steel
----------	-----------------

K	Cast Iron
----------	-----------

S	Titanium
----------	----------

S	Nickel
----------	--------

S	High Temp Alloys
----------	------------------

Feature of product:

Multipurpose End Mills- 4 Flutes · Short Type · Long Neck

Using UMG carbide material and Nano multilayer coating AlTiCrN enable to enhance lubrication and wear resistance.

Effectively decrease the vibration by various helix geometry and unequal flutes designs.

Big chip breaker is designed to reach high removal rate for various work materials.

Designed with step to increase the effective length.

Suitable for different kinds of materials in finishing.

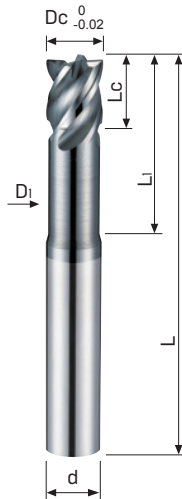

Code No. F612HX-Dc

Dc	Lc	L	d	L1	D1	AlTiCrN
0 -0.02	mm	mm	h5	mm	mm	F612HX
3	4	57	6	9	2.8	●
3.5	4.5	57	6	12	3.3	●
4	5	57	6	12	3.7	●
4.5	5.5	57	6	15	4.2	●
5	6	57	6	15	4.6	●
5.5	6.5	57	6	20	5.1	●
6	7	57	6	20	5.5	●
6.5	7.5	63	8	23	6	●
7	8	63	8	23	6.4	●
7.5	8.5	63	8	26	6.9	●
8	9	63	8	26	7.4	●
8.5	9.5	72	10	29	7.9	●
9	10	72	10	29	8.3	●
9.5	10.5	72	10	31	8.8	●
10	11	72	10	31	9.2	●
10.5	11.5	83	12	34	9.7	●
11	12	83	12	34	10.2	●
11.5	12.5	83	12	37	10.6	●
12	13	83	12	37	11	●
13	14	92	16	38	11.8	●
14	15	92	16	40	12.7	●
15	16	92	16	42	13.6	●
16	17	92	16	43	14.5	●
17	18	104	20	45	15.4	●
18	19	104	20	48	16.3	●
19	20	104	20	51	17.3	●
20	21	104	20	53	18.2	●

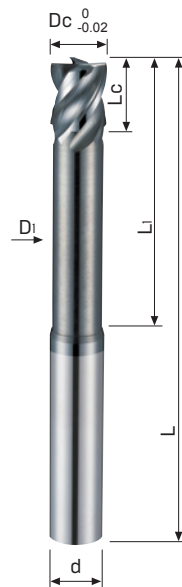

Code No. F617HX-Dc

Dc	Lc	L	d	L1	D1	AlTiCrN
0 -0.02	mm	mm	h5	mm	mm	F617HX
3	4	70	6	18	2.8	●
3.5	4.5	70	6	22	3.3	●
4	5	70	6	22	3.7	●
4.5	5.5	70	6	28	4.2	●
5	6	70	6	28	4.6	●
5.5	6.5	70	6	33	5.4	●
6	7	70	6	33	5.5	●
6.5	7.5	80	8	38	6	●
7	8	80	8	38	6.4	●
7.5	8.5	80	8	43	6.9	●
8	9	80	8	43	7.4	●
8.5	9.5	90	10	45	7.9	●
9	10	90	10	45	8.3	●
9.5	10.5	90	10	49	8.8	●
10	11	90	10	49	9.2	●
10.5	11.5	100	12	52	9.7	●
11	12	100	12	52	10.2	●
11.5	12.5	100	12	54	10.6	●
12	13	100	12	54	11	●
13	14	115	16	60	11.8	●
14	15	115	16	62	12.7	●
15	16	115	16	64	13.6	●
16	17	115	16	66	14.5	●
17	18	130	20	70	15.4	●
18	19	130	20	74	16.3	●
19	20	130	20	76	17.3	●
20	21	130	20	79	18.2	●

Side Milling

Work Material		GR.1 Carbon Steel		GR.2 Low-alloyed Steel (~24HRC)		GR.3 Hi-alloyed Steel (~30HRC)		GR.4 Hardened Steel (30~38HRC)		GR.5 Hardened Steel (38~48HRC)		GR.8 Stainless Steel		GR.9 Cast Iron	
Vc m/min		63		63		63		53		53		60		63	
Code No.	Dc	RPM (min-1)	Feed (mm/min)	RPM (min-1)	Feed (mm/min)	RPM (min-1)	Feed (mm/min)	RPM (min-1)	Feed (mm/min)	RPM (min-1)	Feed (mm/min)	RPM (min-1)	Feed (mm/min)	RPM (min-1)	Feed (mm/min)
F612HX/F617HX-3	3	10,600	683	10,600	683	8,280	530	6,550	389	6,400	105	6,550	389	10,600	683
F612HX/F617HX-4	4	6,350	735	6,350	735	4,950	590	3,950	413	3,800	120	3,950	413	6,350	735
F612HX/F617HX-5	5	4,550	875	4,550	875	3,550	625	2,800	448	2,730	125	2,800	448	4,550	875
F612HX/F617HX-6	6	3,540	875	3,540	875	2,760	600	2,200	413	2,100	125	2,200	413	3,540	875
F612HX/F617HX-7	7	3,360	820	3,360	820	2,620	600	2,085	413	2,000	125	2,085	413	3,360	820
F612HX/F617HX-8	8	3,185	770	3,185	770	2,480	600	1,975	413	1,900	125	1,975	413	3,185	770
F612HX/F617HX-9	9	3,417	770	3,417	770	2,275	600	1,810	394	1,750	120	1,810	394	3,415	770
F612HX/F617HX-10	10	3,650	770	3,650	770	2,070	595	1,645	375	1,595	120	1,645	375	3,650	770
F612HX/F617HX-11	11	2,960	720	2,960	720	1,920	575	1,525	362	1,480	120	1,525	362	2,960	720
F612HX/F617HX-12	12	2,275	670	2,275	670	1,770	560	1,410	350	1,365	120	1,410	350	2,275	670
F612HX/F617HX-13	13	2,300	670	2,300	670	1,715	550	1,365	343	1,370	115	1,365	343	2,200	670
F612HX/F617HX-14	14	2,332	670	2,332	670	1,660	540	1,320	336	1,270	110	1,320	336	2,130	670
F612HX/F617HX-15	15	2,160	670	2,160	670	1,605	530	1,275	324	1,230	105	1,275	324	2,060	670
F612HX/F617HX-16	16	1,990	670	1,990	670	1,550	520	1,230	312	1,190	100	1,230	312	1,990	670
F612HX/F617HX-17	17	1,890	635	1,890	635	1,475	490	1,160	305	1,130	95	1,160	305	1,890	635
F612HX/F617HX-18	18	1,790	600	1,790	600	1,400	465	1,100	295	1,070	95	1,100	295	1,790	600
F612HX/F617HX-19	19	1,690	570	1,690	570	1,320	440	1,040	285	1,010	90	1,040	285	1,690	670
F612HX/F617HX-20	20	1,590	535	1,590	535	1,240	415	985	277	950	90	985	277	1,590	535
(mm)		ap:1.0D		ap:1.0D		ap:1.0D		ap:1.0D		ap:1.0D		ap:1.0D		ap:1.0D	
		ae:0.2D		ae:0.2D		ae:0.2D		ae:0.2D		ae:0.1D		ae:0.2D		ae:0.2D	

Slotting

Work Material		GR.1 Carbon Steel		GR.2 Low-alloyed Steel (~24HRC)		GR.3 Hi-alloyed Steel (~30HRC)		GR.4 Hardened Steel (30~38HRC)		GR.5 Hardened Steel (38~48HRC)		GR.8 Stainless Steel		GR.9 Cast Iron	
Vc m/min		100		100		65		55		55		60		65	
Code No.	Dc	RPM (min-1)	Feed (mm/min)	RPM (min-1)	Feed (mm/min)	RPM (min-1)	Feed (mm/min)	RPM (min-1)	Feed (mm/min)	RPM (min-1)	Feed (mm/min)	RPM (min-1)	Feed (mm/min)	RPM (min-1)	Feed (mm/min)
F612HX/F617HX-3	3	10,600	424	10,600	424	8,280	331	6,550	262	6,400	128	6,550	262	10,600	424
F612HX/F617HX-4	4	6,350	508	6,350	508	4,950	396	3,950	316	3,800	152	3,950	316	6,350	508
F612HX/F617HX-5	5	4,550	455	4,550	455	3,550	355	2,800	280	2,730	164	2,800	280	4,550	455
F612HX/F617HX-6	6	3,540	425	3,540	425	2,760	331	2,200	264	2,100	168	2,200	264	3,540	425
F612HX/F617HX-7	7	3,360	403	3,360	403	2,620	314	2,085	250	2,000	160	2,085	250	3,360	403
F612HX/F617HX-8	8	3,185	510	3,185	510	2,480	397	1,975	316	1,900	152	1,975	316	3,185	510
F612HX/F617HX-9	9	3,417	547	3,417	547	2,275	364	1,810	290	1,750	140	1,810	290	3,415	546
F612HX/F617HX-10	10	3,650	584	3,650	584	2,070	331	1,645	263	1,595	191	1,645	263	3,650	584
F612HX/F617HX-11	11	2,960	592	2,960	592	1,920	384	1,525	305	1,480	178	1,525	305	2,960	592
F612HX/F617HX-12	12	2,275	455	2,275	455	1,770	354	1,410	282	1,365	164	1,410	282	2,275	455
F612HX/F617HX-13	13	2,300	460	2,300	460	1,715	343	1,365	273	1,370	164	1,365	273	2,200	440
F612HX/F617HX-14	14	2,332	466	2,332	466	1,660	332	1,320	264	1,270	152	1,320	264	2,130	426
F612HX/F617HX-15	15	2,160	432	2,160	432	1,605	321	1,275	255	1,230	148	1,275	255	2,060	412
F612HX/F617HX-16	16	1,990	398	1,990	398	1,550	310	1,230	246	1,190	143	1,230	246	1,990	398
F612HX/F617HX-17	17	1,890	378	1,890	378	1,475	295	1,160	232	1,130	136	1,160	232	1,890	378
F612HX/F617HX-18	18	1,790	394	1,790	394	1,400	308	1,100	242	1,070	128	1,100	242	1,790	394
F612HX/F617HX-19	19	1,690	406	1,690	406	1,320	317	1,040	250	1,010	121	1,040	250	1,690	406
F612HX/F617HX-20	20	1,590	445	1,590	445	1,240	347	985	276	950	114	985	276	1,590	445
(mm)		ap:0.5D		ap:0.5D		ap:0.5D		ap:0.5D		ap:0.05D		ap:0.5D		ap:0.5D	

※ Notice: 617HX is Long Length series End Mills. Please adjust the parameter according

E148HX

Multipurpose End Mills · Slim Shank · Short Type

MG
Carbide

AlTiCrN
HX



Type of Operation

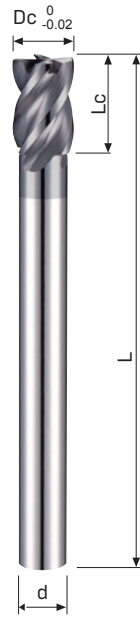

Code No. E148HX-Dc

Dc	Lc	L	d	AlTiCrN
0 -0.02	mm	mm	h6	E148HX
6	9	60	5	●
7	10.5	70	6	●
8	12	75	6	●
9	13.5	80	8	●
10	15	80	8	●
11	16.5	100	10	●
12	18	100	10	●
13	19.5	100	12	●
14	21	110	12	●
15	22.5	110	14	●
16	24	110	14	●
17	22.5	110	16	●
18	27	125	16	●
19	28.5	125	18	●
20	30	125	18	●
22	33	125	20	●

Work Material

P	H	M	K	N	S
●	●	●	●	○	○

P	Steel
----------	-------

H	<38HRC Hardened Steel
----------	--------------------------

H	<48HRC Hardened Steel
----------	--------------------------

M	Stainless Steel
----------	-----------------

K	Cast Iron
----------	-----------

S	Titanium
----------	----------

S	Nickel
----------	--------

S	High Temp Alloys
----------	------------------

Feature of product:

Multipurpose End Mills- 4 Flutes · Slim Shank · Short Type

Effectively decrease the vibration by various helix geometry and unequal flutes designs.

Big chip breaker is designed to reach high removal rate for various work materials.

Obviously improving tool life with Nano multilayer coating AlTiCrN.

Designed with step to increase the effective length.

Suitable for different kinds of materials cutting.

Side Milling

Work Material		GR.1 Carbon Steel		GR.2 Low-alloyed Steel (~24HRC)		GR.3 Hi-alloyed Steel (~30HRC)		GR.4 Hardened Steel (30-38HRC)		GR.5 Hardened Steel (38-48HRC)		GR.8 Stainless Steel		GR.9 Cast Iron		GR.15 Titanium	
Vc m/min		130		130		120		100		60		70		130		30	
Code No.	Dc	RPM (min-1)	Feed (mm/min)	RPM (min-1)	Feed (mm/min)	RPM (min-1)	Feed (mm/min)	RPM (min-1)	Feed (mm/min)	RPM (min-1)	Feed (mm/min)	RPM (min-1)	Feed (mm/min)	RPM (min-1)	Feed (mm/min)	RPM (min-1)	Feed (mm/min)
E148HX-6	6	6,897	1,150	6,897	1,150	6,366	991	5,308	620	3,715	267	4,246	572	6,897	1,150	1,592	100
E148HX-7	7	5,911	1,150	5,911	1,150	5,457	994	4,550	621	3,185	268	3,640	535	5,911	1,150	1,364	100
E148HX-8	8	5,173	1,150	5,173	1,150	4,775	994	3,981	621	2,787	268	3,185	535	5,173	1,150	1,194	100
E148HX-9	9	4,598	1,150	4,598	1,150	4,244	991	3,539	619	2,477	267	2,831	533	4,598	1,150	1,061	100
E148HX-10	10	4,138	1,150	4,138	1,150	3,820	994	3,185	573	2,229	268	2,548	535	4,138	1,150	955	100
E148HX-11	11	3,762	1,100	3,762	1,100	3,472	942	2,895	543	2,027	254	2,316	507	3,762	1,100	868	100
E148HX-12	12	3,448	1,050	3,448	1,050	3,183	891	2,654	557	1,858	240	2,123	480	3,448	1,050	796	90
E148HX-13	13	3,183	1,000	3,183	1,000	2,938	875	2,450	547	1,715	236	1,960	471	3,183	1,000	735	90
E148HX-14	14	2,956	980	2,956	980	2,728	867	2,275	542	1,592	233	1,820	467	2,956	980	682	85
E148HX-15	15	2,759	960	2,759	960	2,546	851	2,123	532	1,486	258	1,699	458	2,759	960	637	100
E148HX-16	16	2,586	950	2,586	950	2,387	845	1,990	528	1,393	256	1,592	455	2,586	950	597	100
E148HX-17	17	2,434	940	2,434	940	2,247	828	1,873	518	1,311	251	1,499	446	2,434	940	562	95
E148HX-18	18	2,299	920	2,299	920	2,122	810	1,769	509	1,238	245	1,415	436	2,299	920	531	95
E148HX-19	19	2,178	910	2,178	910	2,010	808	1,676	505	1,173	245	1,341	435	2,178	910	503	95
E148HX-20	20	2,069	900	2,069	900	1,910	802	1,592	501	1,115	245	1,274	432	2,069	900	477	95
E148HX-22	22	1,881	820	1,881	820	1,736	729	1,448	455	1,013	221	1,158	392	1,881	820	434	90
(mm) 		ap:1.0D		ap:1.0D		ap:1.0D		ap:1.0D		ap:1.0D		ap:1.0D		ap:1.0D		ap:1.0D	
		ae:0.2D		ae:0.2D		ae:0.1D		ae:0.1D		ae:0.05D		ae:0.1D		ae:0.2D		ae:0.05D	

Slotting

Work Material		GR.1 Carbon Steel		GR.2 Low-alloyed Steel (~24HRC)		GR.3 Hi-alloyed Steel (~30HRC)		GR.4 Hardened Steel (30-38HRC)		GR.5 Hardened Steel (38-48HRC)		GR.8 Stainless Steel		GR.9 Cast Iron		GR.15 Titanium	
Vc m/min		130		130		120		100		70		80		130		30	
Code No.	Dc	RPM (min-1)	Feed (mm/min)	RPM (min-1)	Feed (mm/min)	RPM (min-1)	Feed (mm/min)	RPM (min-1)	Feed (mm/min)	RPM (min-1)	Feed (mm/min)	RPM (min-1)	Feed (mm/min)	RPM (min-1)	Feed (mm/min)	RPM (min-1)	Feed (mm/min)
E148HX-6	6	6,897	1,000	6,897	1,000	6,366	828	5,038	478	3,715	223	4,246	350	6,897	1,000	1,592	85
E148HX-7	7	5,911	1,000	5,911	1,000	5,457	831	4,550	479	3,185	224	3,640	352	5,911	1,000	1,364	85
E148HX-8	8	5,173	950	5,173	950	4,775	828	3,981	478	2,787	223	3,185	350	5,173	950	1,194	85
E148HX-9	9	4,598	950	4,598	950	4,244	827	3,539	477	2,477	223	2,831	350	4,598	950	1,061	85
E148HX-10	10	4,138	950	4,138	950	3,820	833	3,185	481	2,229	224	2,548	353	4,138	950	955	90
E148HX-11	11	3,762	900	3,762	900	3,472	786	2,895	454	2,027	212	2,316	333	3,762	900	868	85
E148HX-12	12	3,448	860	3,448	860	3,183	747	2,654	431	1,858	226	2,123	316	3,448	860	796	90
E148HX-13	13	3,183	840	3,183	840	2,938	729	2,450	420	1,715	221	1,960	308	3,183	840	735	90
E148HX-14	14	2,956	820	2,956	820	2,728	722	2,275	416	1,592	219	1,820	305	2,956	820	682	90
E148HX-15	15	2,759	810	2,759	810	2,546	707	2,123	408	1,486	214	1,699	299	2,759	810	637	85
E148HX-16	16	2,586	800	2,586	800	2,387	701	1,990	404	1,393	236	1,592	296	2,586	800	597	90
E148HX-17	17	2,434	780	2,434	780	2,247	687	1,873	396	1,311	231	1,499	290	2,434	780	562	90
E148HX-18	18	2,299	770	2,299	770	2,122	677	1,769	391	1,238	228	1,415	286	2,299	770	531	90
E148HX-19	19	2,178	760	2,178	760	2,010	671	1,676	387	1,173	226	1,341	284	2,178	760	503	92
E148HX-20	20	2,069	750	2,069	750	1,910	649	1,592	375	1,115	240	1,274	275	2,069	750	477	90
E148HX-22	22	1,881	670	1,881	670	1,736	590	1,448	340	1,013	218	1,158	250	1,881	670	434	85
(mm) 		ap:0.5D		ap:0.5D		ap:0.3D		ap:0.3D		ap:0.3D		ap:0.5D		ap:0.5D		ap:0.3D	

1. Please work with good rigidity / high precision facilities and collet chuck.
2. Please choose proper cutting fluid.
3. The cutting data is reference value only. Please adjust it according to your real working conditions.
4. If RPM is lower the reference value, the Feed rate (fz) and RPM should be reduced by the same proportion.
5. If vibration occurs during cutting, please reduce cutting parameter.

E149HX

Multipurpose End Mills · Slim Shank · Long Type

MG
Carbide

AlTiCrN
HX



Type of Operation



Work Material

P	H	M	K	N	S
●	●	●	●	○	○

P Steel

H <38HRC
Hardened Steel

H <48HRC
Hardened Steel

M Stainless Steel

K Cast Iron

S Titanium

S Nickel

S High Temp Alloys

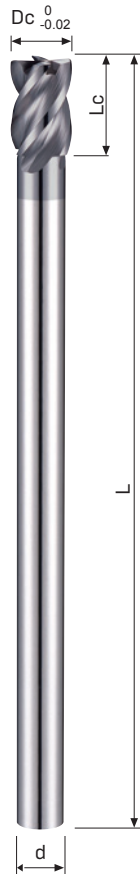

Code No. E149HX-Dc

Dc	Lc	L	d	AlTiCrN
0 -0.02	mm	mm	h6	E149HX
6	9	120	5	●
7	10.5	135	6	●
8	12	135	6	●
9	13.5	135	8	●
10	15	150	8	●
11	16.5	160	10	●
12	18	160	10	●
13	19.5	160	12	●
14	21	160	12	●
15	22.5	180	14	●
16	24	180	14	●
17	22.5	180	16	●
18	27	180	16	●
19	28.5	200	18	●
20	30	200	18	●
22	33	200	20	●

Feature of product:

Multipurpose End Mills- 4 Flutes · Slim Shank · Long Type

Effectively decrease the vibration by various helix geometry and unequal flutes designs.

Big chip breaker is designed to reach high removal rate for various work materials.

Obviously improving tool life with Nano multilayer coating AlTiCrN.

Designed with step to increase the effective length.

Suitable for different kinds of materials cutting.

Side Milling

Work Material		GR.1 Carbon Steel		GR.2 Low-alloyed Steel (~24HRC)		GR.3 Hi-alloyed Steel (~30HRC)		GR.4 Hardened Steel (30-38HRC)		GR.5 Hardened Steel (38-48HRC)		GR.8 Stainless Steel		GR.9 Cast Iron		GR.15 Titanium	
Vc m/min		130		130		120		100		70		80		130		30	
Code No.	Dc	RPM (min-1)	Feed (mm/min)	RPM (min-1)	Feed (mm/min)	RPM (min-1)	Feed (mm/min)	RPM (min-1)	Feed (mm/min)	RPM (min-1)	Feed (mm/min)	RPM (min-1)	Feed (mm/min)	RPM (min-1)	Feed (mm/min)	RPM (min-1)	Feed (mm/min)
E149HX-6	6	6,897	700	6,897	700	6,366	595	5,308	372	3,715	160	4,246	343	6,897	700	1,592	55
E149HX-7	7	5,911	700	5,911	700	5,457	596	4,550	373	3,185	161	3,640	321	5,911	700	1,364	55
E149HX-8	8	5,173	700	5,173	700	4,775	596	3,981	373	2,787	161	3,185	321	5,173	700	1,194	55
E149HX-9	9	4,598	700	4,598	700	4,244	594	3,539	372	2,477	160	2,831	320	4,598	700	1,061	55
E149HX-10	10	4,138	700	4,138	700	3,820	596	3,185	344	2,229	161	2,548	321	4,138	700	955	55
E149HX-11	11	3,762	650	3,762	650	3,472	565	2,895	326	2,027	152	2,316	304	3,762	650	868	50
E149HX-12	12	3,448	650	3,448	650	3,183	535	2,654	334	1,858	144	2,123	288	3,448	650	796	50
E149HX-13	13	3,183	620	3,183	620	2,938	525	2,450	328	1,715	141	1,960	283	3,183	620	735	50
E149HX-14	14	2,956	600	2,956	600	2,728	520	2,275	325	1,592	140	1,820	280	2,956	600	682	50
E149HX-15	15	2,759	600	2,759	600	2,546	511	2,123	319	1,486	155	1,699	275	2,759	600	637	60
E149HX-16	16	2,586	580	2,586	580	2,387	507	1,990	317	1,393	153	1,592	273	2,586	580	597	60
E149HX-17	17	2,434	570	2,434	570	2,247	497	1,873	311	1,311	150	1,499	268	2,434	570	562	57
E149HX-18	18	2,299	560	2,299	560	2,122	486	1,769	304	1,238	147	1,415	262	2,299	560	531	55
E149HX-19	19	2,178	560	2,178	560	2,010	485	1,676	303	1,173	147	1,341	261	2,178	560	503	55
E149HX-20	20	2,069	540	2,069	540	1,910	481	1,592	301	1,115	146	1,274	259	2,069	540	477	55
E149HX-22	22	1,881	500	1,881	500	1,736	437	1,448	273	1,013	132	1,158	235	1,881	500	434	50
(mm) 		ap:1.0D		ap:1.0D		ap:1.0D		ap:1.0D		ap:1.0D		ap:1.0D		ap:1.0D		ap:1.0D	
		ae:0.2D		ae:0.2D		ae:0.1D		ae:0.1D		ae:0.05D		ae:0.1D		ae:0.2D		ae:0.1D	

Slotting

Work Material		GR.1 Carbon Steel		GR.2 Low-alloyed Steel (~24HRC)		GR.3 Hi-alloyed Steel (~30HRC)		GR.4 Hardened Steel (30-38HRC)		GR.5 Hardened Steel (38-48HRC)		GR.8 Stainless Steel		GR.9 Cast Iron		GR.15 Titanium	
Vc m/min		130		130		120		100		70		80		130		30	
Code No.	Dc	RPM (min-1)	Feed (mm/min)	RPM (min-1)	Feed (mm/min)	RPM (min-1)	Feed (mm/min)	RPM (min-1)	Feed (mm/min)	RPM (min-1)	Feed (mm/min)	RPM (min-1)	Feed (mm/min)	RPM (min-1)	Feed (mm/min)	RPM (min-1)	Feed (mm/min)
E149HX-6	6	6,897	550	6,897	550	6,366	414	5,308	239	3,715	111	4,246	175	6,897	550	1,592	45
E149HX-7	7	5,911	540	5,911	540	5,457	415	4,550	240	3,185	112	3,640	176	5,911	540	1,364	45
E149HX-8	8	5,173	530	5,173	530	4,775	414	3,981	239	2,787	111	3,185	175	5,173	530	1,194	45
E149HX-9	9	4,598	510	4,598	510	4,244	414	3,539	239	2,477	111	2,831	175	4,598	510	1,061	40
E149HX-10	10	4,138	500	4,138	500	3,820	417	3,185	240	2,229	112	2,548	176	4,138	500	955	40
E149HX-11	11	3,762	480	3,762	480	3,472	393	2,895	227	2,027	106	2,316	166	3,762	480	868	40
E149HX-12	12	3,448	460	3,448	460	3,183	374	2,654	216	1,858	113	2,123	158	3,448	460	796	40
E149HX-13	13	3,183	440	3,183	440	2,938	364	2,450	210	1,715	110	1,960	154	3,183	440	735	40
E149HX-14	14	2,956	420	2,956	420	2,728	361	2,275	208	1,592	109	1,820	153	2,956	420	682	40
E149HX-15	15	2,759	400	2,759	400	2,546	353	2,123	204	1,486	107	1,699	149	2,759	400	637	40
E149HX-16	16	2,586	400	2,586	400	2,387	350	1,990	202	1,393	118	1,592	148	2,586	400	597	45
E149HX-17	17	2,434	400	2,434	400	2,247	343	1,873	198	1,311	116	1,499	145	2,434	400	562	45
E149HX-18	18	2,299	390	2,299	390	2,122	339	1,769	195	1,238	114	1,415	143	2,299	390	531	45
E149HX-19	19	2,178	390	2,178	390	2,010	335	1,676	193	1,173	113	1,341	142	2,178	390	503	45
E149HX-20	20	2,069	380	2,069	380	1,910	325	1,592	187	1,115	120	1,274	137	2,069	380	477	45
E149HX-22	22	1,881	350	1,881	350	1,736	295	1,448	170	1,013	109	1,158	125	1,881	350	434	40
(mm) 		ap:0.3D		ap:0.3D		ap:0.3D		ap:0.2D		ap:0.05D		ap:0.2D		ap:0.3D		ap:0.2D	

1. Please work with good rigidity / high precision facilities and collet chuck.
2. Please choose proper cutting fluid.
3. The cutting data is reference value only. Please adjust it according to your real working conditions.
4. If RPM is lower the reference value, the Feed rate (fz) and RPM should be reduced by the same proportion.
5. If vibration occurs during cutting, please reduce cutting parameter.

B270TX

Multipurpose End Mills With Corner Radius

Code No. B270TX-Dc×R

UMG
CarbideAlTiSiN
TX

Type of Operation



Work Material

P	H	M	K	N	S
●	●	●	○	●	●

P	Steel
---	-------

H	<38HRC Hardened Steel
---	--------------------------

H	<48HRC Hardened Steel
---	--------------------------

H	<56HRC Hardened Steel
---	--------------------------

H	<68HRC Hardened Steel
---	--------------------------

K	Cast Iron
---	-----------

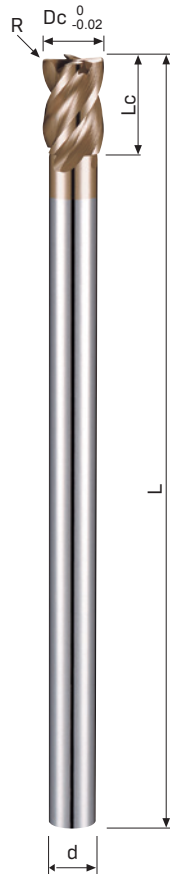

Dc	R	Lc	L	d	AlTiSiN B270TX
0 -0.02	± 0.01	mm	mm	h6	
10	R0.5	15	130	8	●
10	R1	15	130	8	●
12	R0.5	18	150	10	●
12	R1	18	150	10	●
14	R0.5	21	160	12	●
14	R1	21	160	12	●
18	R0.5	27	180	16	●
18	R1	27	180	16	●
22	R0.5	33	200	20	●
22	R1	33	200	20	●

Feature of product:

Multipurpose End Mills with
Corner Radius- 4 Flutes · Slim
Shank · Long Type

Effectively decrease the vibration
by various helix geometry and
unequal flutes designs.

Big chip breaker is designed
to reach high removal rate for
various work materials.

Cutting edge with corner radius
design to increase tool life.

Obviously improving wear and
heat resistance with Nano
multilayer coating AlTiSiN.

Designed with step to increase
the effective length.

Suitable for different kinds of
materials cutting.

Cavity machining







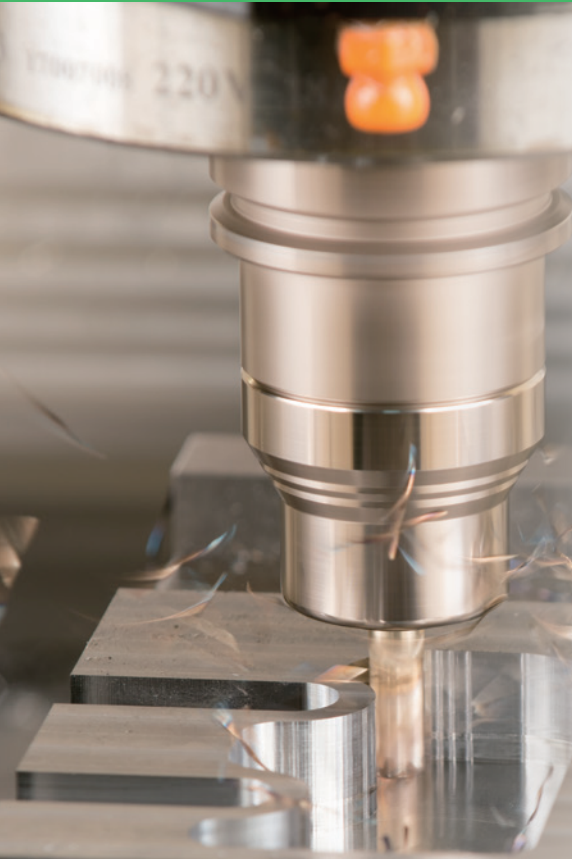







Work Material		GR.1 Carbon Steel		GR.2 Low-alloyed Steel (~24HRC)		GR.3 Hi-alloyed Steel (~30HRC)		GR.4 Hardened Steel (30~38HRC)		GR.5 Hardened Steel (38~48HRC)		GR.6 Hardened Steel (48~56HRC)		GR.7 Hardened Steel (56~68HRC)	
Vc m/min		200		200		200		150		150		120		100	
Code No.	Dc	RPM (min-1)	Feed (mm/min)	RPM (min-1)	Feed (mm/min)	RPM (min-1)	Feed (mm/min)	RPM (min-1)	Feed (mm/min)	RPM (min-1)	Feed (mm/min)	RPM (min-1)	Feed (mm/min)	RPM (min-1)	Feed (mm/min)
B270TX-10	10	6,400	1,300	6,400	1,300	6,400	1,100	4,800	800	4,800	700	3,800	320	3,180	250
B270TX-12	12	5,300	1,300	5,300	1,300	5,300	1,100	4,000	800	4,000	700	3,200	320	2,650	250
B270TX-14	14	4,550	1,300	4,550	1,300	4,550	1,100	3,400	800	3,400	700	2,750	320	2,270	250
B270TX-18	18	3,500	1,300	3,500	1,300	3,500	1,100	2,650	800	2,650	700	2,150	320	1,750	250
B270TX-22	22	2,900	1,300	2,900	1,300	2,900	1,050	2,180	750	2,180	700	1,750	320	1,450	250
(mm) 		ap:0.1D		ap:0.1D		ap:0.1D		ap:0.1D		ap:0.1D		ap:0.05D		ap:0.02D	
		ae:0.3D		ae:0.3D		ae:0.3D		ae:0.3D		ae:0.3D		ae:0.2D		ae:0.2D	

※ The above parameters is recommended in the range of 4XD extended length.

1. Please work with good rigidity / high precision facilities and collet chuck.
2. Please choose proper cutting fluid.
3. The cutting data is reference value only. Please adjust it according to your real working conditions.
4. If RPM is lower the reference value, the Feed rate (fz) and RPM should be reduced by the same proportion.
5. If vibration occurs during cutting, please reduce cutting parameter.



End Mills For Stainless, Titanium

	Page	31	33	35	37	39
Apperance						
Code No		E129SX	E233SX	E234SX E234-2.5SX E234-5.0SX	E235-2.5SX E235-5.0SX	E236TX
Carbide		MG Carbide	MG Carbide	MG Carbide	MG Carbide	MG Carbide
Coating		AlTiXN+ZrN SX	AlTiXN+ZrN SX	AlTiXN+ZrN SX	AlTiXN+ZrN SX	AlTiSiN TX
Helix Angle		 38°	 38°	 38°	 38°	 38°
No.of Flutes		 4	 4	 5	 5	 7

ASIA

E129SX

End Mills for Stainless

MG
Carbide

AlTiXN+ZrN
SX



Type of Operation

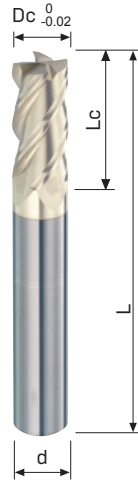
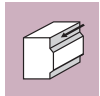
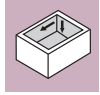

Code No. E129SX-Dc

Dc 0 -0.02	Lc mm	L mm	d h6	AlTiXN+ZrN E129SX
1	3	50	4	●
1.5	5	50	4	●
2	6	50	4	●
2.5	8	50	4	●
3A	8	50	4	●
4A	11	50	4	●
3	8	50	6	●
4	11	50	6	●
5	13	50	6	●
6	16	50	6	●
8	20	60	8	●
10	22	72	10	●
12	26	75	12	●

Work Material

P	H	M	K	N	S
		●			●

M Stainless Steel

S Titanium

S Nickel

S High Temp Alloys

Feature of product:

End Mills for Stainless Steel- 4
Flutes

Sharp cutting edge is suitable
in finishing for difficult-to-cut
materials such as, hardened steel,
stainless steel, titanium alloy,
nickel alloy, high temperature alloy
and etc.

Side Milling

Work Material		GR.8 Stainless Steel	
Vc m/min		65	
Code No.	Dc	RPM (min-1)	Feed (mm/min)
E129SX-1	1	11,100	385
E129SX-1.5	1.5	10,700	490
E129SX-2	2	10,300	600
E129SX-2.5	2.5	8,650	500
E129SX-3	3	7,000	400
E129SX-4	4	5,200	410
E129SX-5	5	4,100	410
E129SX-6	6	3,500	450
E129SX-8	8	2,600	460
E129SX-10	10	2,050	470
E129SX-12	12	1,800	500
 (mm)		ap:1.5D	
		ae:0.1D	

1. Please work with good rigidity / high precision facilities and collet chuck.
2. Please choose proper cutting fluid.
3. The cutting data is reference value only. Please adjust it according to your real working conditions.
4. If RPM is lower the reference value, the Feed rate [fz] and RPM should be reduced by the same proportion.
5. If vibration occurs during cutting, please reduce cutting parameter.

E233SX

End Mills for Stainless

MG
Carbide



Type of Operation



Work Material

P	H	M	K	N	S
		●			●

M Stainless Steel

S Titanium

S Nickel

S High Temp Alloys

Feature of product:

End Mills for Stainless Steel- 4 Flutes

Sharp cutting edge is suitable in roughing and finishing for difficult-to-cut materials such as, hardened steel, stainless steel, titanium alloy, nickel alloy, high temperature alloy and etc.

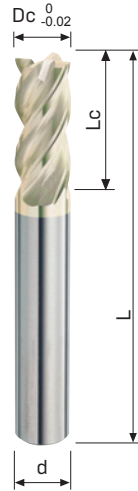

Code No. E233SX-Dc

Dc 0 -0.02	Lc mm	L mm	d h6	AlTiXN+ZrN E233SX
3	8	50	6	●
4	11	50	6	●
5	13	50	6	●
6	16	50	6	●
8	20	60	8	●
10	22	72	10	●
12	26	75	12	●

Side Milling

Work Material		GR.8 Stainless Steel	
Vc m/min		75	
Code No.	Dc	RPM (min-1)	Feed (mm/min)
E233SX-3	3	7,650	600
E233SX-4	4	6,050	700
E233SX-5	5	5,000	770
E233SX-6	6	4,200	830
E233SX-8	8	3,100	800
E233SX-10	10	2,600	710
E233SX-12	12	2,100	670
E233SX-16	16	1,600	550
E233SX-20	20	1,250	510
 (mm)		ap:1.5D	
		ae:0.1D	

Slotting

Work Material		GR.8 Stainless Steel	
Vc m/min		70	
Code No.	Dc	RPM (min-1)	Feed (mm/min)
E233SX-3	3	7,450	450
E233SX-4	4	5,500	500
E233SX-5	5	4,500	530
E233SX-6	6	3,700	550
E233SX-8	8	2,800	525
E233SX-10	10	2,300	465
E233SX-12	12	1,850	430
E233SX-16	16	1,400	370
E233SX-20	20	1,100	330
 (mm)		ap:0.5D	

1. Please work with good rigidity / high precision facilities and collet chuck.
2. Please choose proper cutting fluid.
3. The cutting data is reference value only. Please adjust it according to your real working conditions.
4. If RPM is lower the reference value, the Feed rate (fz) and RPM should be reduced by the same proportion.
5. If vibration occurs during cutting, please reduce cutting parameter.

E234SX / E234-2.5SX / E234-5.0SX

End Mills for Stainless

MG
Carbide

AlTiXN+ZrN
SX



Type of Operation

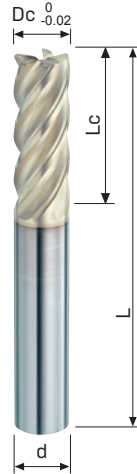

Code No. E234SX-Dc

Dc 0 -0.02	Lc mm	L mm	d h6	AlTiXN+ZrN E234SX
3	8	50	6	●
4	11	50	6	●
5	13	50	6	●
6	16	50	6	●
8	20	60	8	●
10	22	72	10	●
12	26	75	12	●

Work Material

P	H	M	K	N	S
		●			●

M Stainless Steel

S Titanium

S Nickel

S High Temp Alloys

Feature of product:

End Mills for Stainless Steel- 5
Flutes

Sharp cutting edge is suitable
in roughing and finishing for
difficult-to-cut materials such as,
hardened steel, stainless steel,
titanium alloy, nickel alloy, high
temperature alloy and etc.

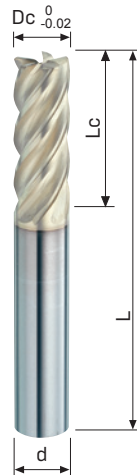

Code No. E234-2.5SX-Dc

Dc 0 -0.02	Lc mm	L mm	d h6	AlTiXN+ZrN E234-2.5SX
6	15	50	6	●
8	20	60	8	●
10	25	72	10	●
12	30	75	12	●
16	40	100	16	●
20	50	100	20	●

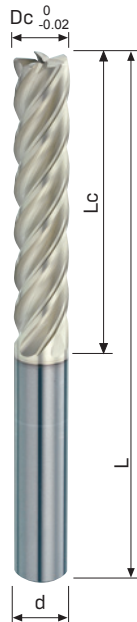

Code No. E234-5.0SX-Dc

Dc 0 -0.02	Lc mm	L mm	d h6	AlTiXN+ZrN E234-5.0SX
6	30	75	6	●
8	40	90	8	●
10	50	100	10	●
12	60	110	12	●
16	80	160	16	●
20	100	200	20	●

E234SX / Side Milling

Work Material		GR.8 Stainless Steel	
Vc m/min		75	
Code No.	Dc	RPM (min-1)	Feed (mm/min)
E234SX-3	3	7,650	720
E234SX-4	4	6,050	840
E234SX-5	5	5,000	920
E234SX-6	6	4,200	990
E234SX-8	8	3,100	960
E234SX-10	10	2,600	850
E234SX-12	12	2,100	800
E234SX-16	16	1,600	660
E234SX-20	20	1,250	615
 (mm)		ap:1.5D	
		ae:0.1D	

E234-2.5SX / Side Milling

Work Material		GR.8 Stainless Steel	
Vc m/min		75	
Code No.	Dc	RPM (min-1)	Feed (mm/min)
E234-2.5SX-6	6	4,200	990
E234-2.5SX-8	8	3,100	960
E234-2.5SX-10	10	2,600	850
E234-2.5SX-12	12	2,100	800
E234-2.5SX-16	16	1,600	660
E234-2.5SX-20	20	1,250	615
 (mm)		ap:1.5D	
		ae:0.1D	

E234-5.0SX / Side Milling

Work Material		GR.8 Stainless Steel	
Vc m/min		75	
Code No.	Dc	RPM (min-1)	Feed (mm/min)
E234-5.0SX-6	6	2,120	500
E234-5.0SX-8	8	1,590	475
E234-5.0SX-10	10	1,275	410
E234-5.0SX-12	12	1,060	400
E234-5.0SX-16	16	800	300
E234-5.0SX-20	20	640	250
 (mm)		ap:3.0D	
		ae:0.05D	

1. Please work with good rigidity / high precision facilities and collet chuck.
2. Please choose proper cutting fluid.
3. The cutting data is reference value only. Please adjust it according to your real working conditions.
4. If RPM is lower the reference value, the Feed rate (fz) and RPM should be reduced by the same proportion.
5. If vibration occurs during cutting, please reduce cutting parameter.

E235-2.5SX / 5.0SX

End Mills With Corner Radius for Stainless

MG
Carbide

AlTiXN+ZrN
SX



Type of Operation

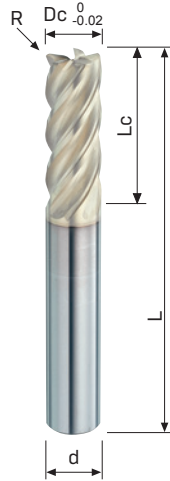

Code No. E235-2.5SX-Dc×R

Dc	R	Lc	L	d	AlTiXN+ZrN E235-2.5SX
$0_{-0.02}$	± 0.01	mm	mm	h6	
6	0.5	15	50	6	●
8	0.5	20	60	8	●
10	0.5	25	72	10	●
12	0.5	30	75	12	●
16	0.5	40	100	16	●
20	0.5	50	100	20	●

Work Material

P	H	M	K	N	S
		●			●

M Stainless Steel

S Titanium

S Nickel

S High Temp Alloys

Feature of product:

End Mills for Stainless Steel- 5
Flutes

Sharp cutting edge is suitable
in roughing and finishing for
difficult-to-cut materials such as,
hardened steel, stainless steel,
titanium alloy, nickel alloy, high
temperature alloy and etc.

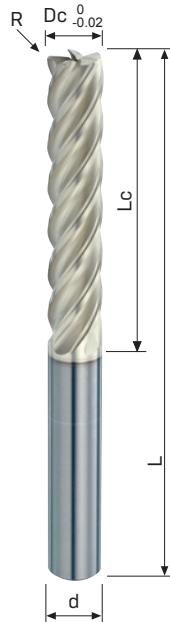

Code No. E235-5.0SX-Dc×R

Dc	R	Lc	L	d	AlTiXN+ZrN E235-5.0SX
$0_{-0.02}$	± 0.01	mm	mm	h6	
6	0.5	30	75	6	●
8	0.5	40	90	8	●
10	0.5	50	100	10	●
12	0.5	60	110	12	●
16	0.5	80	160	16	●
20	0.5	100	200	20	●

E235-2.5SX / Side Milling

Work Material		GR.8 Stainless Steel	
Vc m/min		75	
Code No.	Dc	RPM (min-1)	Feed (mm/min)
E235-2.5SX-6	6	4,200	990
E235-2.5SX-8	8	3,100	960
E235-2.5SX-10	10	2,600	850
E235-2.5SX-12	12	2,100	800
E235-2.5SX-16	16	1,600	660
E235-2.5SX-20	20	1,250	615
 (mm)		ap:1.5D	
		ae:0.1D	

E235-5.0SX / Side Milling

Work Material		GR.8 Stainless Steel	
Vc m/min		75	
Code No.	Dc	RPM (min-1)	Feed (mm/min)
E235-5.0SX-6	6	2,120	500
E235-5.0SX-8	8	1,590	475
E235-5.0SX-10	10	1,275	410
E235-5.0SX-12	12	1,060	400
E235-5.0SX-16	16	800	300
E235-5.0SX-20	20	640	250
 (mm)		ap:3.0D	
		ae:0.05D	

1. Please work with good rigidity / high precision facilities and collet chuck.
2. Please choose proper cutting fluid.
3. The cutting data is reference value only. Please adjust it according to your real working conditions.
4. If RPM is lower the reference value, the Feed rate (fz) and RPM should be reduced by the same proportion.
5. If vibration occurs during cutting, please reduce cutting parameter.

E236TX

End Mills With Corner Radius for Titanium

MG
CarbideAlTiSiN
TX

Type of Operation

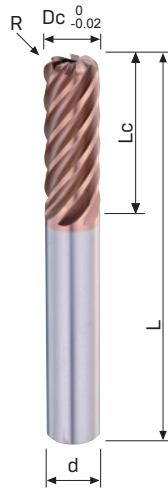

Code No. E236TX-Dc×R

Dc	R	Lc	L	d	AlTiSiN E236TX
$\begin{matrix} 0 \\ -0.02 \end{matrix}$	± 0.01	mm	mm	h6	●
10	2	25	72	10	●
12	3	30	75	12	●
16	4	48	100	16	●
20	4	60	120	20	●

Work Material

P	H	M	K	N	S
					●

S Titanium

S Nickel

S High Temp Alloys

Feature of product:

End Mills for difficult-to-cut materials- 7 Flutes

Suitable for High Precision Cutting in roughing and High Speed Cutting in finishing.



Sharp cutting edge is good at cutting difficult-to-cut materials such as hardened steel, stainless steel, titanium alloy, nickel alloy, high temperature alloy and etc.

Side Milling

Work Material		GR.15 Titanium		GR.16 Nickel		GR.17 High Temp Alloys	
Vc m/min		60		40		40	
Code No.	Dc	RPM [min-1]	Feed [mm/min]	RPM [min-1]	Feed [mm/min]	RPM [min-1]	Feed [mm/min]
E236TX-10	10	1,900	580	1,270	380	1,270	380
E236TX-12	12	1,060	630	1,060	290	1,060	290
E236TX-16	16	800	540	800	240	800	240
E236TX-20	20	630	520	630	225	630	225
(mm)		ap:1.0D		ap:1.0D		ap:1.0D	
		ae:0.05D		ae:0.05D		ae:0.05D	

1. Please work with good rigidity / high precision facilities and collet chuck.
2. Please choose proper cutting fluid.
3. The cutting data is reference value only. Please adjust it according to your real working conditions.
4. If RPM is lower the reference value, the Feed rate [fz] and RPM should be reduced by the same proportion.
5. If vibration occurs during cutting, please reduce cutting parameter.

End Mills For Aluminium

Page	43	45	47	49	51	53
Apperance						
Code No	E132 E134	E142	E143DX	E143	E143-3.0 E143-4.0 E143-5.0	E145
Carbide	MG Carbide	MG Carbide	MG Carbide	MG Carbide	MG Carbide	MG Carbide
Coating	Uncoated Bright	Uncoated Bright	DLC DX	Uncoated Bright	Uncoated Bright	Uncoated Bright
Helix Angle	 30°	 40°	 40°	 40°	 40°	 40°
No.of Flutes	 2	 2	 3	 3	 3	 3

ASIA

55

57

57



E194

E195R

E195L

MG
Carbide

MG
Carbide

MG
Carbide

Uncoated
Bright

Uncoated
Bright

Uncoated
Bright



40°



30°



30°



Z



1



1

E132 / E134

End Mills For Aluminium

MG Carbide **Uncoated Bright**

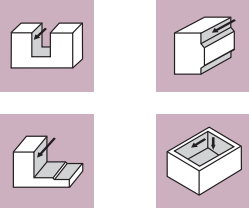
**Type of Operation****Work Material**

N Aluminium

N Copper

Feature of product:

End Mills for Aluminium with Standard & Long Length- 2 Flutes
With sharp cutting edge and larger chip removal space.

Higher finishing of cutting edge to have better surface roughness after processing.

Application for roughing and finishing in various Aluminium and Copper.

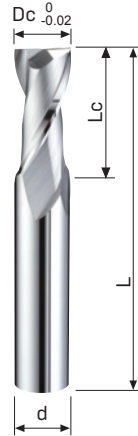

Code No. E132-Dc

Dc 0 -0.02	Lc mm	L mm	d h6	Bright E132
1.0	3	50	4	●
1.5	5	50	4	●
2.0	6	50	4	●
2.5	8	50	4	●
3.0	8	50	6	●
4.0	11	50	6	●
5.0	13	50	6	●
6.0	16	50	6	●
8.0	20	60	8	●
10.0	22	72	10	●
12.0	26	75	12	●

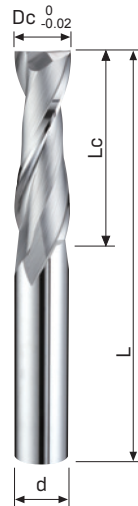

Code No. E134-Dc

Dc 0 -0.02	Lc mm	L mm	d h6	Bright E134
3	12	50	6	●
4	17	50	6	●
5	20	60	6	●
6	20	60	6	●
8	28	70	8	●
10	34	80	10	●
12	40	90	12	●

Slotting

Work Material		GR.10 Aluminium	
Vc m/min		100	
Code No.	Dc	RPM (min ⁻¹)	Feed (mm/min)
E132-1	1	31,500	200
E132-1.5	1.5	21,000	200
E132-2	2	15,500	200
E132-2.5	2.5	13,000	250
E132/E134-3	3	10,500	300
E132/E134-4	4	8,000	300
E132/E134-5	5	6,350	300
E132/E134-6	6	5,300	300
E132/E134-8	8	4,000	300
E132/E134-10	10	3,200	300
E132/E134-12	12	2,650	300
 (mm)		ap:1.0D	

※ Notice: E134 is Long Length series End Mills. Please adjust the parameter according.

1. Please work with good rigidity / high precision facilities and collet chuck.
2. Please choose proper cutting fluid.
3. The cutting data is reference value only. Please adjust it according to your real working conditions.
4. If RPM is lower the reference value, the Feed rate (fz) and RPM should be reduced by the same proportion.
5. If vibration occurs during cutting, please reduce cutting parameter.

E142

End Mills For Aluminium

Code No. E142-Dc

MG Carbide
Uncoated Bright



Type of Operation



Work Material

P	H	M	K	N	S
				●	

N Aluminium

N Copper

Feature of product:

End Mills for Aluminium- 2 Flutes

Design with sharp cutting edge, high removal cutting geometry, and fine grinding smooth surface to prevent sticking problem.

Larger helix angle to get better finishing.

Higher finishing of cutting edge to have better surface roughness after processing.

Application for roughing and finishing in various Aluminium and Copper.

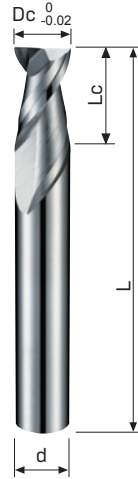

Dc 0 -0.02	Lc mm	L mm	d h6	Bright E142
3	8	50	6	●
3.1	10	50	6	●
3.2	10	50	6	●
3.3	10	50	6	●
3.4	10	50	6	●
3.5	10	50	6	●
3.6	10	50	6	●
3.7	10	50	6	●
3.8	11	50	6	●
3.9	11	50	6	●
4	11	50	6	●
4.1	11	50	6	●
4.2	11	50	6	●
4.3	11	50	6	●
4.4	11	50	6	●
4.5	11	50	6	●
4.6	11	50	6	●
4.7	11	50	6	●
4.8	13	50	6	●
4.9	13	50	6	●
5	13	50	6	●
5.1	13	50	6	●
5.2	13	50	6	●
5.3	13	50	6	●
5.4	13	50	6	●
5.5	13	50	6	●
5.6	16	50	6	●
5.7	16	50	6	●
5.8	16	50	6	●
5.9	16	50	6	●
6	16	50	6	●
6.1	16	60	8	●
6.2	16	60	8	●
6.3	16	60	8	●
6.4	16	60	8	●
6.5	16	60	8	●
6.6	20	60	8	●
6.7	20	60	8	●
6.8	20	60	8	●
6.9	20	60	8	●
7	20	60	8	●
7.1	20	60	8	●
7.2	20	60	8	●
7.3	20	60	8	●
7.4	20	60	8	●
7.5	20	60	8	●
7.6	20	60	8	●
7.7	20	60	8	●
7.8	20	60	8	●
7.9	20	60	8	●
8	20	60	8	●
8.5	20	72	10	●
9	25	72	10	●
9.5	25	72	10	●
10	25	72	10	●
10.5	25	75	12	●
11	30	75	12	●
11.5	30	75	12	●
12	30	75	12	●

Slotting

Work Material		GR.10 Aluminium	
Vc m/min		150~380	
Code No.	Dc	RPM [min-1]	Feed [mm/min]
E142-3	3	16,000	1,280
E142-3.5	3.5	14,000	1,120
E142-4	4	12,000	960
E142-4.5	4.5	10,800	1,240
E142-5	5	9,600	1,520
E142-5.5	5.5	8,800	1,400
E142-6	6	8,000	1,280
E142-6.5	6.5	7,500	1,200
E142-7	7	7,000	1,120
E142-7.5	7.5	6,500	1,040
E142-8	8	6,000	960
E142-8.5	8.5	7,500	1,120
E142-9	9	9,000	1,280
E142-9.5	9.5	10,500	1,440
E142-10	10	12,000	1,600
E142-10.5	10.5	11,500	1,600
E142-11	11	11,000	1,600
E142-11.5	11.5	10,500	1,600
E142-12	12	10,000	1,600
(mm)		ap:0.5D	

1. Please work with good rigidity / high precision facilities and collet chuck.
2. Please choose proper cutting fluid.
3. The cutting data is reference value only. Please adjust it according to your real working conditions.
4. If RPM is lower the reference value, the Feed rate [fz] and RPM should be reduced by the same proportion.
5. If vibration occurs during cutting, please reduce cutting parameter.

E143DX

End Mills For Aluminium

MG
CarbideDLC
DX

Type of Operation



Work Material

P	H	M	K	N	S
				●	

N Aluminium

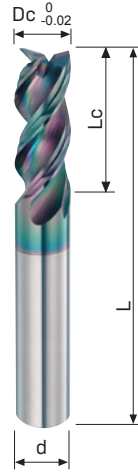

Code No. E143DX-Dc

Dc 0 -0.02	Lc mm	L mm	d h6	DLC E143DX
3	8	50	6	●
4	11	50	6	●
5	13	50	6	●
6	16	50	6	●
8	20	60	8	●
10	25	72	10	●
12	30	75	12	●
16	40	100	16	●
20	40	100	20	●

Feature of product:

End Mills for Aluminium with
Diamond coating- 3 Flutes

Design with sharp cutting edge,
high removal cutting geometry,
and fine grinding smooth surface
to prevent sticking problem.

Higher finishing of cutting edge.

With high abrasion DLC diamond
coating type to enhance surface
lubrication and wear resistance.

Application for roughing and
finishing in various Aluminium.

Side Milling

Work Material		GR.10 Aluminium	
Vc m/min		400	
Code No.	Dc	RPM [min-1]	Feed [mm/min]
E143DX-3	3	42,000	1,900
E143DX-4	4	31,000	2,200
E143DX-5	5	25,000	2,200
E143DX-6	6	21,000	2,400
E143DX-8	8	16,000	2,600
E143DX-10	10	12,700	3,000
E143DX-12	12	10,600	3,200
E143DX-14	14	9,100	3,200
E143DX-16	16	8,000	3,200
E143DX-20	20	6,300	3,100
(mm)		ap:1.5D	
		ae:0.1D	

Slotting

Work Material		GR.10 Aluminium	
Vc m/min		400	
Code No.	Dc	RPM [min-1]	Feed [mm/min]
E143DX-3	3	42,000	1,340
E143DX-4	4	31,000	1,400
E143DX-5	5	25,000	1,480
E143DX-6	6	21,000	1,640
E143DX-8	8	16,000	1,720
E143DX-10	10	12,700	1,940
E143DX-12	12	10,600	2,100
E143DX-14	14	9,100	2,100
E143DX-16	16	7,900	2,100
E143DX-20	20	6,300	2,100
(mm)		0.5D	

1. Please work with good rigidity / high precision facilities and collet chuck.
2. Please choose proper cutting fluid.
3. The cutting data is reference value only. Please adjust it according to your real working conditions.
4. If RPM is lower the reference value, the Feed rate (fz) and RPM should be reduced by the same proportion.
5. If vibration occurs during cutting, please reduce cutting parameter.

E143

End Mills For Aluminium

MG Carbide **Uncoated Bright**

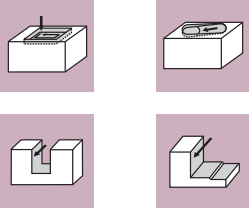
**Type of Operation****Work Material**

P	H	M	K	N	S
				●	

N Aluminium

Feature of product:

End Mills for Aluminium- 3 Flutes
Design with sharp cutting edge, high removal cutting geometry, and fine grinding smooth surface to prevent sticking problem.

Higher finishing of cutting edge to have better surface roughness after processing.

Application for roughing and finishing in various Aluminium.

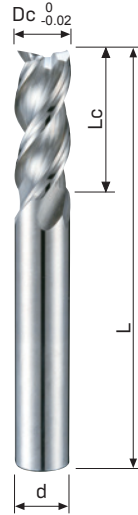

Code No. E143-Dc

Dc 0 -0.02	Lc mm	L mm	d h6	Bright E143
1	3	50	4	●
1.5	5	50	4	●
2	6	50	4	●
2.5	8	50	4	●
3	8	50	6	●
4	11	50	6	●
5	13	50	6	●
6	16	50	6	●
8	20	60	8	●
10	25	72	10	●
12	30	75	12	●
14	35	100	16	●
16	40	100	16	●
18	40	100	20	●
20	40	100	20	●

Side Milling

Work Material		GR.10 Aluminium	
Vc m/min		400	
Code No.	Dc	RPM [min-1]	Feed [mm/min]
E143-1	1	63,000	1,890
E143-1.5	1.5	50,000	1,500
E143-2	2	45,000	1,755
E143-2.5	2.5	42,000	1,800
E143-3	3	42,000	1,900
E143-4	4	31,000	2,200
E143-5	5	25,000	2,200
E143-6	6	21,000	2,400
E143-7	7	18,500	2,400
E143-8	8	16,000	2,600
E143-9	9	14,500	2,800
E143-10	10	12,700	3,000
E143-12	12	10,600	3,200
E143-14	14	9,100	3,200
E143-16	16	8,000	3,200
E143-18	18	7,000	3,100
E143-20	20	6,300	3,100
(mm)		ap:1.5D	
		ae:0.1D	

Slotting

Work Material		GR.10 Aluminium	
Vc m/min		400	
Code No.	Dc	RPM [min-1]	Feed [mm/min]
E143-1	1	63,000	1,320
E143-1.5	1.5	50,000	1,050
E143-2	2	45,000	1,230
E143-2.5	2.5	42,000	1,260
E143-3	3	42,000	1,340
E143-4	4	31,000	1,400
E143-5	5	25,000	1,480
E143-6	6	21,000	1,640
E143-7	7	18,500	1,640
E143-8	8	16,000	1,720
E143-9	9	14,500	1,800
E143-10	10	12,700	1,940
E143-12	12	10,600	2,100
E143-14	14	9,100	2,100
E143-16	16	7,900	2,100
E143-18	18	7,000	2,100
E143-20	20	6,300	2,100
(mm)		0.5D	

1. Please work with good rigidity / high precision facilities and collet chuck.
2. Please choose proper cutting fluid.
3. The cutting data is reference value only. Please adjust it according to your real working conditions.
4. If RPM is lower the reference value, the Feed rate (fz) and RPM should be reduced by the same proportion.
5. If vibration occurs during cutting, please reduce cutting parameter.

E143-3.0 / 4.0 / 5.0

End Mills For Aluminium

MG Carbide **Uncoated Bright**



Type of Operation



Work Material

P	H	M	K	N	S
				●	

N Aluminium

Feature of product:

End Mills for Aluminium- 3 Flutes
Design with sharp cutting edge,
high removal cutting geometry,
and fine grinding smooth surface
to prevent sticking problem.

Higher finishing of cutting edge
to have better surface roughness
after processing.

Application for roughing and
finishing in various Aluminium.

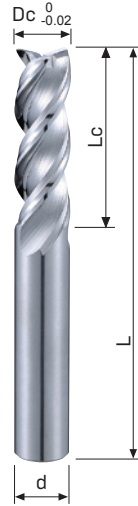

Code No. E143-3.0-Dc

Dc 0 -0.02	Lc mm	L mm	d h6	Bright E143-3.0
3	9	50	6	●
4	12	50	6	●
5	15	50	6	●
6	18	50	6	●
7	21	65	8	●
8	24	65	8	●
9	27	75	10	●
10	30	75	10	●
12	36	80	12	●
14	42	100	16	●
16	48	100	16	●
18	54	120	20	●
20	60	120	20	●

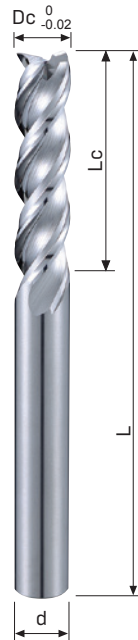

Code No. E143-4.0-Dc

Dc 0 -0.02	Lc mm	L mm	d h6	Bright E143-4.0
3	12	50	6	●
4	16	55	6	●
5	20	60	6	●
6	24	65	6	●
7	28	90	8	●
8	32	90	8	●
9	36	100	10	●
10	40	100	10	●
12	48	110	12	●
14	56	140	16	●
16	64	140	16	●
18	72	160	20	●
20	80	160	20	●

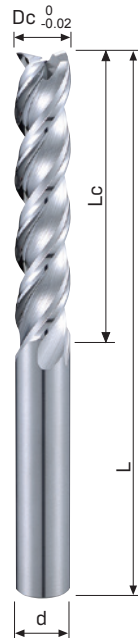

Code No. E143-5.0-Dc

Dc 0 -0.02	Lc mm	L mm	d h6	Bright E143-5.0
3	15	55	6	●
4	20	60	6	●
5	25	65	6	●
6	30	75	6	●
7	35	90	8	●
8	40	90	8	●
9	45	100	10	●
10	50	100	10	●
12	60	110	12	●
14	70	160	16	●
16	80	160	16	●
18	90	200	20	●
20	100	200	20	●

Side Milling

Work Material		GR.10 Aluminium	
Vc m/min		400	
Code No.	Dc	RPM (min ⁻¹)	Feed (mm/min)
E143-3.0/E143-4.0/E143-5.0	3	42,000	1,000
E143-3.0/E143-4.0/E143-5.0	4	31,000	1,400
E143-3.0/E143-4.0/E143-5.0	5	25,000	1,800
E143-3.0/E143-4.0/E143-5.0	6	21,000	2,000
E143-3.0/E143-4.0/E143-5.0	7	18,200	2,100
E143-3.0/E143-4.0/E143-5.0	8	16,000	2,200
E143-3.0/E143-4.0/E143-5.0	9	14,000	2,300
E143-3.0/E143-4.0/E143-5.0	10	12,700	2,400
E143-3.0/E143-4.0/E143-5.0	12	10,600	2,200
E143-3.0/E143-4.0/E143-5.0	14	9,100	2,100
E143-3.0/E143-4.0/E143-5.0	16	8,000	2,000
E143-3.0/E143-4.0/E143-5.0	18	7,100	1,900
E143-3.0/E143-4.0/E143-5.0	20	6,300	1,800
(mm) 		ap:2.5D	
		ae:0.1D	

1. Please work with good rigidity / high precision facilities and collet chuck.
2. Please choose proper cutting fluid.
3. The cutting data is reference value only. Please adjust it according to your real working conditions.
4. If RPM is lower the reference value, the Feed rate (fz) and RPM should be reduced by the same proportion.
5. If vibration occurs during cutting, please reduce cutting parameter.

E145

End Mills For Aluminium

Code No. E145-Dc×R

MG Carbide **Uncoated Bright**



Type of Operation

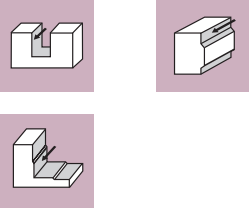

Work Material

P	H	M	K	N	S
				●	

N Aluminium

N Copper

N Graphite

Feature of product:

End Mills with Corner Radius for Aluminium- 3 Flutes Short Type - Long Neck

Design with sharp cutting edge, high removal cutting geometry, and fine grinding smooth surface to prevent sticking problem.

Higher finishing of cutting edge to have better surface roughness after processing.

With corner Radius to enhance tool life.

Application for roughing and finishing in various Aluminium.

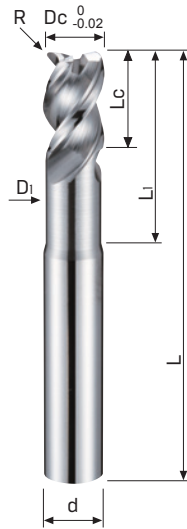

Dc 0 -0.02	R ±0.01	Lc mm	L mm	d h6	L1 mm	D1 mm	Bright E145
3	—	4.5	50	6	9	2.8	●
3	R0.1	4.5	50	6	9	2.8	●
3	R0.2	4.5	50	6	9	2.8	●
3	R0.3	4.5	50	6	9	2.8	●
3	R0.5	4.5	50	6	9	2.8	●
4	—	6	50	6	12	3.7	●
4	R0.1	6	50	6	12	3.7	●
4	R0.2	6	50	6	12	3.7	●
4	R0.3	6	50	6	12	3.7	●
4	R0.5	6	50	6	12	3.7	●
5	—	7.5	60	6	15	4.6	●
5	R0.1	7.5	60	6	15	4.6	●
5	R0.2	7.5	60	6	15	4.6	●
5	R0.3	7.5	60	6	15	4.6	●
5	R0.5	7.5	60	6	15	4.6	●
6	—	9	60	6	18	5.5	●
6	R0.2	9	60	6	18	5.5	●
6	R0.3	9	60	6	18	5.5	●
6	R0.5	9	60	6	18	5.5	●
6	R0.8	9	60	6	18	5.5	●
6	R1.2	9	60	6	18	5.5	●
6	R1.5	9	60	6	18	5.5	●
6	R1.6	9	60	6	18	5.5	●
6	R2	9	60	6	18	5.5	●
8	—	12	70	8	24	7.3	●
8	R0.2	12	70	8	24	7.3	●
8	R0.3	12	70	8	24	7.3	●
8	R0.5	12	70	8	24	7.3	●
8	R0.8	12	70	8	24	7.3	●
8	R1	12	70	8	24	7.3	●
8	R1.2	12	70	8	24	7.3	●
8	R1.5	12	70	8	24	7.3	●
8	R1.6	12	70	8	24	7.3	●
8	R2	12	70	8	24	7.3	●
8	R3	12	70	8	24	7.3	●
10	—	15	80	10	30	9.2	●
10	R0.2	15	80	10	30	9.2	●
10	R0.3	15	80	10	30	9.2	●
10	R0.5	15	80	10	30	9.2	●
10	R0.8	15	80	10	30	9.2	●
10	R1	15	80	10	30	9.2	●
10	R1.2	15	80	10	30	9.2	●
10	R1.5	15	80	10	30	9.2	●
10	R1.6	15	80	10	30	9.2	●
10	R2	15	80	10	30	9.2	●
10	R3	15	80	10	30	9.2	●
12	—	18	90	12	36	11	●
12	R0.2	18	90	12	36	11	●
12	R0.3	18	90	12	36	11	●
12	R0.5	18	90	12	36	11	●
12	R0.8	18	90	12	36	11	●
12	R1	18	90	12	36	11	●
12	R1.2	18	90	12	36	11	●
12	R1.5	18	90	12	36	11	●
12	R1.6	18	90	12	36	11	●
12	R2	18	90	12	36	11	●
12	R3	18	90	12	36	11	●
16	—	24	110	16	48	14.5	●
16	R0.5	24	110	16	48	14.5	●
16	R1	24	110	16	48	14.5	●
16	R2	24	110	16	48	14.5	●
16	R3	24	110	16	48	14.5	●
16	R4	24	110	16	48	14.5	●
20	—	30	125	20	60	18.2	●
20	R0.5	30	125	20	60	18.2	●
20	R1	30	125	20	60	18.2	●
20	R2	30	125	20	60	18.2	●
20	R3	30	125	20	60	18.2	●
20	R4	30	125	20	60	18.2	●

Side Milling

Work Material		GR.10 Aluminium	
Vc m/min		400	
Code No.	Dc	RPM [min-1]	Feed [mm/min]
E145-3	3	42,000	1,900
E145-4	4	31,000	2,200
E145-5	5	25,000	2,200
E145-6	6	21,000	2,400
E145-8	8	16,000	2,600
E145-10	10	12,700	3,000
E145-12	12	10,600	3,200
E145-16	16	8,000	3,200
E145-20	20	6,300	3,100
(mm) 		ap:0.75D	
		ae:0.3D	

Slotting

Work Material		GR.10 Aluminium	
Vc m/min		400	
Code No.	Dc	RPM [min-1]	Feed [mm/min]
E145-3	3	42,000	1,340
E145-4	4	31,000	1,400
E145-5	5	25,000	1,480
E145-6	6	21,000	1,640
E145-8	8	16,000	1,720
E145-10	10	12,700	1,940
E145-12	12	10,600	2,100
E145-16	16	7,900	2,100
E145-20	20	6,300	2,100
(mm) 		0.75D	

1. Please work with good rigidity / high precision facilities and collet chuck.
2. Please choose proper cutting fluid.
3. The cutting data is reference value only. Please adjust it according to your real working conditions.
4. If RPM is lower the reference value, the Feed rate (fz) and RPM should be reduced by the same proportion.
5. If vibration occurs during cutting, please reduce cutting parameter.

E194

Utmost Finishing End Mills For Aluminium

MG Carbide **Uncoated Bright**



Type of Operation

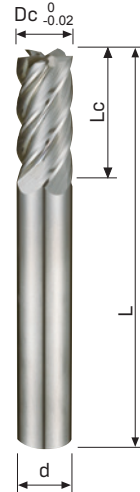
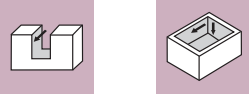

Code No. E194-Dc

Dc 0 -0.02	Lc mm	L mm	d h6	Z	Bright E194
3	8	50	6	3	●
4	11	50	6	3	●
5	13	50	6	4	●
6	16	50	6	4	●
8	20	60	8	4	●
10	22	72	10	5	●
12	26	75	12	5	●

Work Material

P	H	M	K	N	S
				●	

N	Aluminium
---	-----------

Feature of product:

Finishing End Mills for Aluminium-
Multiple Flutes

Design with sharp cutting edge,
high removal cutting geometry,
and fine grinding smooth surface
to prevent sticking problem.

Higher finishing of cutting edge
to have better surface roughness
after processing.

Design with Multiple Flutes to
enhance working efficiency.

Application for finishing in various
Aluminium.

Side Milling

Work Material		GR.10 Aluminium	
Vc m/min		120	
Code No.	Dc	RPM [min-1]	Feed [mm/min]
E194-3	3	12,500	900
E194-4	4	9,500	950
E194-5	5	7,600	970
E194-6	6	6,350	990
E194-8	8	4,800	1,000
E194-10	10	3,800	1,000
E194-12	12	3,200	1,100
(mm) 		ap:1.5D	
		ae:0.1D	

1. Please work with good rigidity / high precision facilities and collet chuck.
2. Please choose proper cutting fluid.
3. The cutting data is reference value only. Please adjust it according to your real working conditions.
4. If RPM is lower the reference value, the Feed rate (fz) and RPM should be reduced by the same proportion.
5. If vibration occurs during cutting, please reduce cutting parameter.

E195R / E195L

End Mills For Aluminium

MG Carbide **Uncoated Bright**

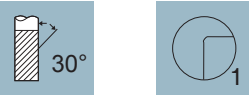
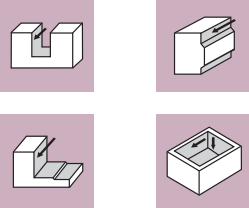
**Type of Operation****Work Material**

N Aluminium

Feature of product:

E195R End Mills with Right-Hand for Aluminium- Single Point

E195L End Mills with Left-Hand for Aluminium- Single Point

Design with sharp cutting edge, high removal cutting geometry, and fine grinding smooth surface to prevent sticking problem.

Higher finishing of cutting edge to have better surface roughness after processing.

Design with large chip removal space.

Chips will be removed downwards while cutting process.

Application for finishing in various Aluminium.

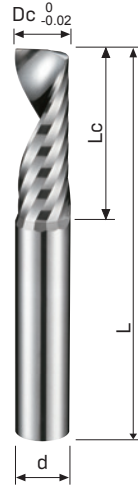

Code No. E195R-Dc

Dc	Lc	L	d	Bright
0 -0.02	mm	mm	h6	E195R
3	12	38	3	●
4	15	50	4	●
6	18	50	6	●
8	22	60	8	●
10	30	72	10	●
12	30	75	12	●

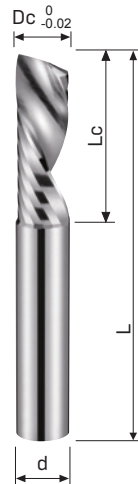

Code No. E195L-Dc

Dc	Lc	L	d	Bright
0 -0.02	mm	mm	h6	E195L
3	12	38	3	●
4	15	50	4	●
6	18	50	6	●
8	22	60	8	●
10	30	72	10	●
12	30	75	12	●













Slotting

Work Material		GR.10 Aluminium	
Vc m/min		188	
Code No.	Dc	RPM (min-1)	Feed (mm/min)
E195R/E195L-3	3	20,000	6,000
E195R/E195L-4	4	15,000	5,000
E195R/E195L-6	6	10,000	5,000
E195R/E195L-8	8	8,400	4,000
E195R/E195L-10	10	6,700	4,000
E195R/E195L-12	12	5,000	5,000
(mm) 		ap:0.5D	

1. Please work with good rigidity / high precision facilities and collet chuck.
2. Please choose proper cutting fluid.
3. The cutting data is reference value only. Please adjust it according to your real working conditions.
4. If RPM is lower the reference value, the Feed rate (fz) and RPM should be reduced by the same proportion.
5. If vibration occurs during cutting, please reduce cutting parameter.

Routers For Composite Materials



Page	61	63	63	63	65	65
Apperance						
Code No	E190 E191	E197	E198	E199	E298	E299
Carbide	MG Carbide	MG Carbide	MG Carbide	MG Carbide	MG Carbide	MG Carbide
Coating	Uncoated Bright	Uncoated Bright	Uncoated Bright	Uncoated Bright	Uncoated Bright	Uncoated Bright
Helix Angle						
No.of Flutes						

ASIA

67

67

69

69



E291

E294

E189R

E189L

MG
Carbide

MG
Carbide

MG
Carbide

MG
Carbide

Uncoated
Bright

Uncoated
Bright

Uncoated
Bright

Uncoated
Bright



10°



10°



21°



21°



1



4



1



1

E190 / E191

Routers For Composite Materials

MG Carbide **Uncoated Bright**

Diamond SP3



Type of Operation

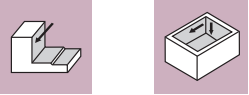

Work Material

P	H	M	K	N	S
				●	

N FRP CFRP
Composite Material

Feature of product:

Routers for Composite Materials
Design with Staggered blade.

Use to cut out fibers in the material to avoid fiber pulling out.

Application for roughing in Phenolic-epoxy parts, Polyester glass reinforced products, Graphite, Composite...etc.

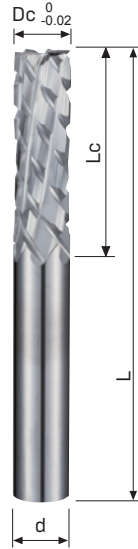

Code No. E190-Dc

Dc 0 -0.02	Lc mm	L mm	d h6	Z T	Bright E190	Diamond E190SP
3	9	50	3	4	●	○
4	12	60	4	4	●	○
6	18	70	6	6	●	○
8	24	75	8	6	●	○
10	30	80	10	6	●	○
12	36	80	12	8	●	○

※ Mark: ○, On request, no stock

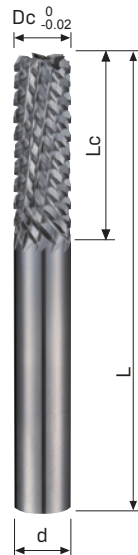

Code No. E191-Dc

Dc 0 -0.02	Lc mm	L mm	d h6	Z T	Bright E191	Diamond E191SP
3	9	50	3	6	●	○
4	12	60	4	6	●	○
6	18	70	6	8	●	○
8	24	75	8	10	●	○
10	30	80	10	12	●	○
12	36	80	12	14	●	○

※ Mark: ○, On request, no stock

Side Milling

Work Material		GR.13 FRP CFRP Composite Material	
Vc m/min		188	
Code No.	Dc	RPM [min ⁻¹]	Feed [mm/min]
E190/E191-3	3	20,000	6,000
E190/E191-4	4	15,000	5,000
E190/E191-6	6	10,000	5,000
E190/E191-8	8	8,400	4,000
E190/E191-10	10	6,700	4,000
E190/E191-12	12	5,000	5,000
(mm)		ap:0.5D	

1. Please work with good rigidity / high precision facilities and collet chuck.
2. Please choose proper cutting fluid.
3. The cutting data is reference value only. Please adjust it according to your real working conditions.
4. If RPM is lower the reference value, the Feed rate (fz) and RPM should be reduced by the same proportion.
5. If vibration occurs during cutting, please reduce cutting parameter.

Routers For Composite Materials

MG Carbide **Uncoated Bright**

Diamond SP3

Type of Operation

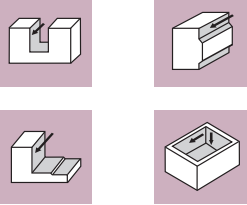

Work Material

P	H	M	K	N	S
				●	

N FRP CFRP Composite Material

Feature of product:

Routers for Composite Materials
Design with Staggered blade.
Use to cut out fibers in the material to avoid fiber pulling out.
Application for roughing in Phenolic-epoxy parts, Polyester glass reinforced products, Graphite, Composite...etc.

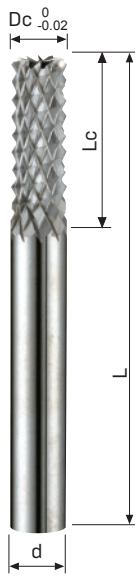

Code No. E197-Dc

Dc 0 -0.02	Lc mm	L mm	d h6	Bright E197	Diamond E197SP
3	12	38	3	●	○
4	15	50	4	●	○
6	18	50	6	●	○
8	22	60	8	●	○
10	30	72	10	●	○
12	30	75	12	●	○

※ Mark: ○, On request, no stock

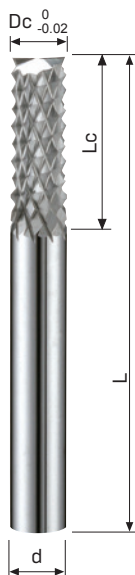

Code No. E198-Dc

Dc 0 -0.02	Lc mm	L mm	d h6	Bright E198	Diamond E198SP
3	12	38	3	●	○
4	15	50	4	●	○
6	18	50	6	●	○
8	22	60	8	●	○
10	30	72	10	●	○
12	30	75	12	●	○

※ Mark: ○, On request, no stock

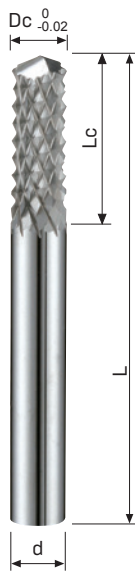

Code No. E199-Dc

Dc 0 -0.02	Lc mm	L mm	d h6	Bright E199	Diamond E199SP
3	12	38	3	●	○
4	15	50	4	●	○
6	18	50	6	●	○
8	22	60	8	●	○
10	30	72	10	●	○
12	30	75	12	●	○

※ Mark: ○, On request, no stock

Slotting

Work Material		GR.13 FRP CFRP Composite Material	
Vc m/min		188	
Code No.	Dc	RPM [min ⁻¹]	Feed [mm/min]
E197/E198/E199-3	3	20,000	6,000
E197/E198/E199-4	4	15,000	5,000
E197/E198/E199-6	6	10,000	5,000
E197/E198/E199-8	8	8,400	4,000
E197/E198/E199-10	10	6,700	4,000
E197/E198/E199-12	12	5,000	5,000
(mm)		ap:0.5D	

1. Please work with good rigidity / high precision facilities and collet chuck.
2. Please choose proper cutting fluid.
3. The cutting data is reference value only. Please adjust it according to your real working conditions.
4. If RPM is lower the reference value, the Feed rate (fz) and RPM should be reduced by the same proportion.
5. If vibration occurs during cutting, please reduce cutting parameter.

E298 / E299

Routers For Composite Materials

MG Carbide **Uncoated Bright**

Diamond SP3

Type of Operation

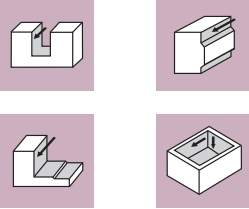

Work Material

P	H	M	K	N	S
				●	

N FRP CFRP Composite Material

Feature of product:

Routers for Composite Materials
Design with Staggered blade.

End cutting edge with drill tip design which could be applied for drilling.

Use to cut out fibers in the material to avoid fiber pulling out.

Application for roughing in Phenolic-epoxy parts, Polyester glass reinforced products, Graphite, Composite...etc.

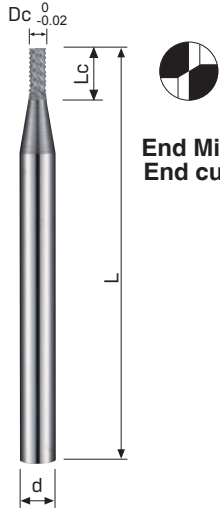

End Mill End cut



Code No. E298-Dc

Dc 0 -0.02	Lc mm	L mm	d h6	Bright E298	Diamond E298SP
1.5	3.0	50	4	●	○
1.8	3.6	50	4	●	○
2.0	4.0	50	4	●	○
2.5	5.0	50	4	●	○
3.0	6.0	50	4	●	○

※ Mark: ○, On request, no stock



135° Drill Point



Code No. E299-Dc

Dc 0 -0.02	Lc mm	L mm	d h6	Bright E299	Diamond E299SP
1.5	3.0	50	4	●	○
1.8	3.6	50	4	●	○
2.0	4.0	50	4	●	○
2.5	5.0	50	4	●	○
3.0	6.0	50	4	●	○

※ Mark: ○, On request, no stock

Slotting

Work Material		GR.13 FRP CFRP Composite Material	
Vc m/min		40~200	
Code No.	Dc	RPM (min-1)	Feed (mm/min)
E298/E299-1.5	1.5	20,000	4,000
E298/E299-1.8	1.8	20,000	4,000
E298/E299-2.0	2.0	20,000	5,000
E298/E299-2.5	2.5	20,000	6,000
E298/E299-3.0	3.0	20,000	6,000
(mm)		ap:0.5D	

1. Please work with good rigidity / high precision facilities and collet chuck.
2. Please choose proper cutting fluid.
3. The cutting data is reference value only. Please adjust it according to your real working conditions.
4. If RPM is lower the reference value, the Feed rate (fz) and RPM should be reduced by the same proportion.
5. If vibration occurs during cutting, please reduce cutting parameter.

E291 / E294

Routers For Composite Materials

MG Carbide
Uncoated Bright



Diamond SP3

Type of Operation

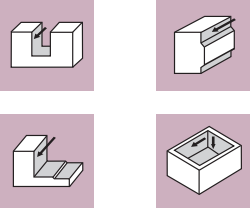

Work Material

P	H	M	K	N	S
				●	

N FRP CFRP Composite Material

Feature of product:

E291 Routers for Composite Materials- Single Point

Design with large chip removal space.

E294 Routers for Composite Materials- 4 Flutes

Design with lower Helix.

Better surface roughness after processing.

Application for finishing in composite materials.

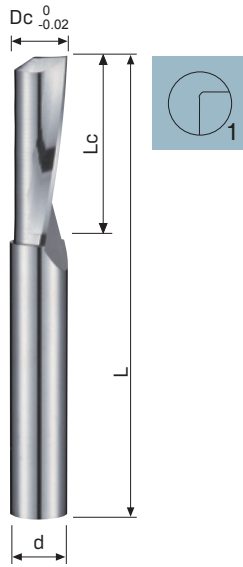

Code No. E291-Dc

Dc 0 -0.02	Lc mm	L mm	d h6	Bright E291	Diamond E291SP
3	9	50	3	●	○
4	12	60	4	●	○
6	18	70	6	●	○
8	24	75	8	●	○
10	30	80	10	●	○
12	36	80	12	●	○

※ Mark: ○, On request, no stock

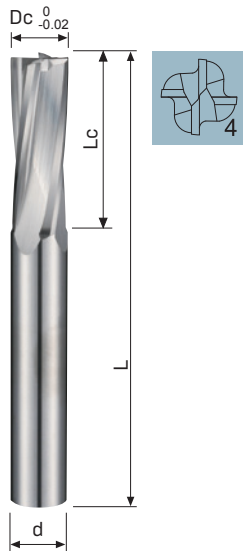

Code No. E294-Dc

Dc 0 -0.02	Lc mm	L mm	d h6	Bright E294	Diamond E294SP
3	9	50	3	●	○
4	12	60	4	●	○
6	18	70	6	●	○
8	24	75	8	●	○
10	30	80	10	●	○
12	36	80	12	●	○

※ Mark: ○, On request, no stock

E291 / Slotting

Work Material		GR.13 FRP CFRP Composite Material	
Vc m/min		188	
Code No.	Dc	RPM [min-1]	Feed [mm/min]
E291-3	3	20,000	6,000
E291-4	4	15,000	5,000
E291-6	6	10,000	5,000
E291-8	8	8,400	4,000
E291-10	10	6,700	4,000
E291-12	12	5,000	5,000
(mm)		ap:0.5D	

E294 / Slotting

Work Material		GR.13 FRP CFRP Composite Material	
Vc m/min		200	
Code No.	Dc	RPM [min-1]	Feed [mm/min]
E294-3	3	21,000	4,200
E294-4	4	16,000	3,200
E294-6	6	10,000	3,200
E294-8	8	8,000	2,560
E294-10	10	6,400	3,072
E294-12	12	5,300	3,180
(mm)		ap:0.5D	

1. Please work with good rigidity / high precision facilities and collet chuck.
2. Please choose proper cutting fluid.
3. The cutting data is reference value only. Please adjust it according to your real working conditions.
4. If RPM is lower the reference value, the Feed rate (fz) and RPM should be reduced by the same proportion.
5. If vibration occurs during cutting, please reduce cutting parameter.

E189R / E189L

End Mills For Plastics

MG Carbide
Uncoated Bright



Type of Operation



Work Material



N Plastics

Feature of product:

E189R End Mills with Right-Hand for Plastic- Single Point

E189L End Mills with Left-Hand for Plastic- Single Point

Design with sharp cutting edge, high removal cutting geometry, and fine grinding smooth surface to prevent sticking problem.

Higher finishing of cutting edge to have better surface roughness after processing.

Chips will be removed upwards/ downwards while cutting process.

Application for finishing in various plastic materials.

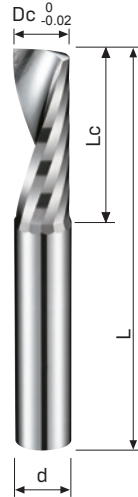

Code No. E189R-Dc

Dc 0 -0.02	Lc mm	L mm	d h6	Bright E189R
3	12	50	3	●
4	15	50	4	●
6	20	63	6	●
8	25	63	8	●
10	30	72	10	●
12	38	75	12	●

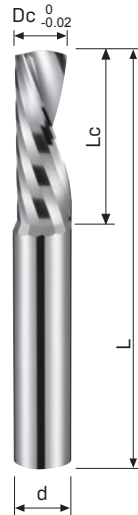

Code No. E189L-Dc













Dc 0 -0.02	Lc mm	L mm	d h6	Bright E189L
3	12	50	3	●
4	15	50	4	●
6	20	63	6	●
8	25	63	8	●
10	30	72	10	●
12	38	75	12	●

Slotting

Work Material		GR.12 Plastics	
Vc m/min		188	
Code No.	Dc	RPM (min-1)	Feed (mm/min)
E189R/E189L-3	3	20,000	6,000
E189R/E189L-4	4	15,000	5,000
E189R/E189L-6	6	10,000	5,000
E189R/E189L-8	8	8,400	4,000
E189R/E189L-10	10	6,700	4,000
E189R/E189L-12	12	5,000	5,000
 (mm)		ap:0.5D	

1. Please work with good rigidity / high precision facilities and collet chuck.
2. Please choose proper cutting fluid.
3. The cutting data is reference value only. Please adjust it according to your real working conditions.
4. If RPM is lower the reference value, the Feed rate (fz) and RPM should be reduced by the same proportion.
5. If vibration occurs during cutting, please reduce cutting parameter.

Short End Mills For Lathe Machine

Page	73	73	75	75
Apperance				
Code No	E113X	E114X	E115HX	E116HX
Carbide	MG Carbide	MG Carbide	MG Carbide	MG Carbide
Coating	AlTiN X-NaNo	AlTiN X-NaNo	AlTiCrN HX	AlTiCrN HX
Helix Angle	 35°	 36° 38°	 38° 41°	 38° 41°
No.of Flutes	 3	 4	 3	 4

ASIA

E113X / E114X

Short End Mills For Lathe

Work Material

P	H	M	K	N	S
●	●	○	●	○	○

P	Steel
----------	-------

H	<38HRC Hardened Steel
----------	--------------------------

H	<48HRC Hardened Steel
----------	--------------------------

M	Stainless Steel
----------	-----------------

K	Cast Iron
----------	-----------

N	Copper
----------	--------

Feature of product:

E113X End Mills For Lathe- 3 Flutes
E114X End Mills For Lathe- 4 Flutes
Widely used with driven tool holder in CNC Lathe.

Perform excellent wear resistance with AITiN coating.

Short cutting length is to prevent from interruption in lathe.

Applied in various steel material up to HRC48.



MG Carbide	AITiN X-NaNo	35°	3	N r10°	90°
-------------------	---------------------	-----	---	------------------	-----

Code No. E113X-Dc					
Dc	Lc	L	d	AITiN E113X	
0 -0.02	mm	mm	h6		
2	3	50	6	●	
3	5	50	6	●	
4	6	50	6	●	
5	8	50	6	●	
6	10	50	6	●	
8	12	50	8	●	
10	15	50	10	●	

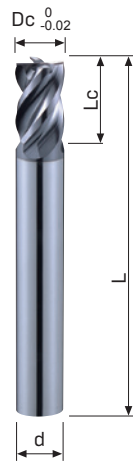

MG Carbide	AITiN X-NaNo	36° 38°	4	N r8°	90°
-------------------	---------------------	------------	---	-----------------	-----

Code No. E114X-Dc					
Dc	Lc	L	d	AITiN E114X	
0 -0.02	mm	mm	h6		
2	3	50	6	●	
3	5	50	6	●	
4	6	50	6	●	
5	8	50	6	●	
6	10	50	6	●	
8	12	50	8	●	
10	15	50	10	●	

Slotting

Work Material		GR.1 Carbon Steel		GR.2 Low-alloyed Steel (~24HRC)		GR.3 Hi-alloyed Steel (~30HRC)		GR.4 Hardened Steel (30~38HRC)		GR.5 Hardened Steel (38~48HRC)		GR.9 Cast Iron		GR.11 Copper	
Vc m/min		80		80		60		50		30		80		100	
Code No.	Dc	RPM (min-1)	Feed (mm/min)	RPM (min-1)	Feed (mm/min)	RPM (min-1)	Feed (mm/min)	RPM (min-1)	Feed (mm/min)	RPM (min-1)	Feed (mm/min)	RPM (min-1)	Feed (mm/min)	RPM (min-1)	Feed (mm/min)
E113X/E114X-2	2	11,000	135	11,000	135	7,000	90	6,350	70	3,950	40	11,000	135	15,500	200
E113X/E114X-3	3	7,400	200	7,400	200	5,300	100	4,450	75	2,750	45	7,400	200	10,500	300
E113X/E114X-4	4	5,950	235	5,950	235	4,250	125	3,500	90	2,200	50	5,950	235	7,950	300
E113X/E114X-5	5	5,300	315	5,300	315	3,550	130	3,050	100	1,900	55	5,300	315	6,350	300
E113X/E114X-6	6	4,450	310	4,450	310	2,950	130	2,500	100	1,550	55	4,450	310	5,300	300
E113X/E114X-8	8	3,300	295	3,300	295	2,200	125	1,900	100	1,150	50	3,300	295	3,950	300
E113X/E114X-10	10	2,650	280	2,650	280	1,750	125	1,500	95	955	50	2,650	280	3,150	300
 (mm)		ap: < 0.3D ≥ 3 0.5D		ap: < 0.3D ≥ 3 0.5D		ap: < 0.3D ≥ 3 0.5D		ap: < 0.3D ≥ 3 0.5D		ap: < 3 0.02D ≥ 3 0.05D		ap: < 0.3D ≥ 3 0.5D		ap: < 0.3D ≥ 3 0.5D	

1. Please work with good rigidity / high precision facilities and collet chuck.
2. Please choose proper cutting fluid.
3. The cutting data is reference value only. Please adjust it according to your real working conditions.
4. If RPM is lower the reference value, the Feed rate [fz] and RPM should be reduced by the same proportion.
5. If vibration occurs during cutting, please reduce cutting parameter.

E115HX / E116HX

Short End Mills For Lathe

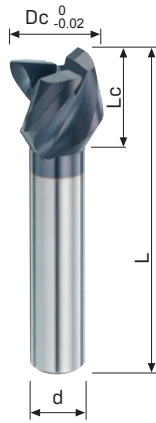

Work Material

P	H	M	K	N	S
●	●	●	●	○	○

P	Steel
---	-------

H	<38HRC Hardened Steel
---	--------------------------

H	<48HRC Hardened Steel
---	--------------------------

M	Stainless Steel
---	-----------------

N	Aluminium
---	-----------

N	Copper
---	--------

Feature of product:

E115HX End Mills For Lathe- 3
Flutes

E116HX End Mills For Lathe- 4
Flutes

Widely used with driven tool holder
in CNC Lathe.

Perform excellent wear resistance
with AlTiCrN coating.

The very short tool length is to
prevent from interruption in lathe.

Increase the commonality by
adopting the same small shank
diameter.

Applied in various steel material
up to HRC48.

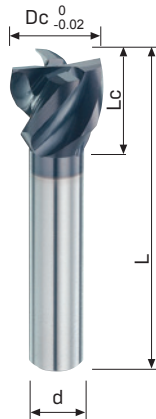

MG
Carbide

AlTiCrN
HX



Code No. E115HX-Dc

Dc 0 -0.02	Lc mm	L mm	d h6	AlTiCrN E115HX
2	6	35	4	●
3	6	35	4	●
4	6	35	4	●
5	6	35	6	●
6	6	35	6	●
7	6	35	6	●
8	6	35	6	●
8A	6	35	8	●
9	6	35	6	●
10	6	35	6	●
10A	6	35	10	●
12	6	35	6	●
12A	6	35	12	●

MG
Carbide

AlTiCrN
HX



Code No. E116HX-Dc

Dc 0 -0.02	Lc mm	L mm	d h6	AlTiCrN E116HX
2	6	35	4	●
3	6	35	4	●
4	6	35	4	●
5	6	35	6	●
6	6	35	6	●
7	6	35	6	●
8	6	35	6	●
8A	6	35	8	●
9	6	35	6	●
10	6	35	6	●
10A	6	35	10	●
12	6	35	6	●
12A	6	35	12	●

Side Milling



















Work Material		GR.1 Carbon Steel		GR.2 Low-alloyed Steel (~24HRC)		GR.3 Hi-alloyed Steel (~30HRC)		GR.4 Hardened Steel (30~38HRC)		GR.5 Hardened Steel (38~48HRC)		GR.8 Stainless Steel	
Vc m/min		100~120		100~120		100~120		65~80		55~70		55~70	
Code No.	Dc	RPM (min-1)	Feed (mm/min)	RPM (min-1)	Feed (mm/min)	RPM (min-1)	Feed (mm/min)	RPM (min-1)	Feed (mm/min)	RPM (min-1)	Feed (mm/min)	RPM (min-1)	Feed (mm/min)
E115HX/E116HX-3	3	10,000	600	10,000	600	10,000	600	7,000	400	7,000	400	6,000	300
E115HX/E116HX-4	4	7,500	600	7,500	600	7,500	600	5,200	400	5,200	400	4,500	300
E115HX/E116HX-5	5	6,000	600	6,000	600	6,000	600	4,200	400	4,200	400	3,600	300
E115HX/E116HX-6	6	5,000	600	5,000	600	5,000	600	3,500	400	3,500	400	3,000	300
E115HX/E116HX-7	7	4,500	560	4,500	560	4,500	560	3,000	360	3,000	360	2,700	280
E115HX/E116HX-8	8	4,000	520	4,000	520	4,000	520	2,800	350	2,800	350	2,400	260
E115HX/E116HX-9	9	3,600	500	3,600	500	3,600	500	2,500	320	2,500	320	2,200	250
E115HX/E116HX-10	10	3,200	450	3,200	450	3,200	450	2,200	300	2,200	300	1,900	230
E115HX/E116HX-12	12	2,700	410	2,700	410	2,700	410	1,900	270	1,900	270	1,600	210
(mm)		ap:1.0D		ap:1.0D		ap:1.0D		ap:1.0D		ap:1.0D		ap:1.0D	
		ae:0.2D		ae:0.2D		ae:0.2D		ae:0.2D		ae:0.2D		ae:0.2D	

Slotting

Work Material		GR.1 Carbon Steel		GR.2 Low-alloyed Steel (~24HRC)		GR.3 Hi-alloyed Steel (~30HRC)		GR.4 Hardened Steel (30~38HRC)		GR.5 Hardened Steel (38~48HRC)		GR.8 Stainless Steel	
Vc m/min		100~120		100~120		100~120		65~80		55~70		55~70	
Code No.	Dc	RPM (min-1)	Feed (mm/min)	RPM (min-1)	Feed (mm/min)	RPM (min-1)	Feed (mm/min)	RPM (min-1)	Feed (mm/min)	RPM (min-1)	Feed (mm/min)	RPM (min-1)	Feed (mm/min)
E115HX/E116HX-3	3	10,000	600	10,000	600	10,000	600	7,000	400	7,000	400	6,000	300
E115HX/E116HX-4	4	7,500	600	7,500	600	7,500	600	5,200	400	5,200	400	4,500	300
E115HX/E116HX-5	5	6,000	600	6,000	600	6,000	600	4,200	400	4,200	400	3,600	300
E115HX/E116HX-6	6	5,000	600	5,000	600	5,000	600	3,500	400	3,500	400	3,000	300
E115HX/E116HX-7	7	4,500	560	4,500	560	4,500	560	3,000	360	3,000	360	2,700	280
E115HX/E116HX-8	8	4,000	520	4,000	520	4,000	520	2,800	350	2,800	350	2,400	260
E115HX/E116HX-9	9	3,600	500	3,600	500	3,600	500	2,500	320	2,500	320	2,200	250
E115HX/E116HX-10	10	3,200	450	3,200	450	3,200	450	2,200	300	2,200	300	1,900	230
E115HX/E116HX-12	12	2,700	410	2,700	410	2,700	410	1,900	270	1,900	270	1,600	210
(inch)		ap:0.2D		ap:0.2D		ap:0.2D		ap:0.2D		ap:0.2D		ap:0.2D	

1. Please work with good rigidity / high precision facilities and collet chuck.
2. Please choose proper cutting fluid.
3. The cutting data is reference value only. Please adjust it according to your real working conditions.
4. If RPM is lower the reference value, the Feed rate (fz) and RPM should be reduced by the same proportion.
5. If vibration occurs during cutting, please reduce cutting parameter.

End Mills For Chamfering

Page	79	79	79	81	81	81
Apperance						
Code No	E106X-60°	E107X-90°	E107X-120°	E108X-60°	E109X-90°	E109X-120°
Carbide	MG Carbide	MG Carbide	MG Carbide	UMG Carbide	UMG Carbide	UMG Carbide
Coating	AlTiN X-NaNo	AlTiN X-NaNo	AlTiN X-NaNo	AlTiN X-NaNo	AlTiN X-NaNo	AlTiN X-NaNo
Helix Angle	 30°	 30°	 30°	 0°	 0°	 0°
No.of Flutes	 2	 2	 2	 4	 4	 4

ASIA

83

83

85

87



E121HX

E123HX

E110HX

E120HX

MG
Carbide

MG
Carbide

MG
Carbide

MG
Carbide

AlTiCrN
HX

AlTiCrN
HX

AlTiCrN
HX

AlTiCrN
HX



45°



45°



15°



15°



3



3



3~6Z



3~6Z

E106X / E107X

End Mills For Chamfering 60° / 90° / 120°

MG
Carbide

AlTiN
X-NaNo

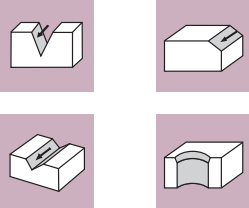
Type of Operation

Work Material

P	H	M	K	N	S
●	●	○	●	●	○

P Steel

H <38HRC
Hardened Steel

H <48HRC
Hardened Steel

M Stainless Steel

K Cast Iron

N Aluminium

N Copper

Feature of product:

E106 / E106X-60° End Mills for Chamfering 60°- 2 Flutes

E107 / E107X-90° End Mills for Chamfering 90°- 2 Flutes

E107 / E107X-120° End Mills for Chamfering 120°- 2 Flutes

Suitable for drilling, tapering, countersinking, NC Spot drilling and frame milling.

Specially for uncoated aluminium alloy.

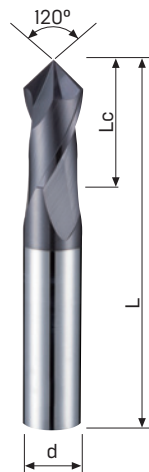
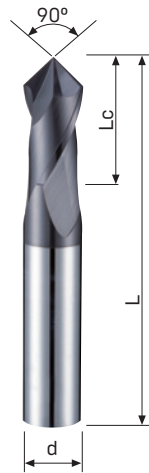

Code No. E106X-60°-Dc

Dc 0 -0.02	Lc mm	L mm	d h6	Bright E106-60°	AlTiN E106X-60°
1	2	38	3	●	●
2	4	38	3	●	●
3	6	50	3	●	●
4	8	50	4	●	●
5	12	50	6	●	●
6	12	50	6	●	●
8	16	60	8	●	●
10	20	72	10	●	●
12	24	75	12	●	●
16	32	100	16	●	●
20	40	100	20	●	●

Code No. E107X-90°-Dc

Dc 0 -0.02	Lc mm	L mm	d h6	Bright E107-90°	AlTiN E107X-90°
0.5	1	38	3		●
0.6	1.2	38	3		●
0.8	1.6	38	3		●
1	2	38	3	●	●
1.2	2.4	38	3		●
1.5	3	38	3		●
1.8	3.6	38	3		●
2	4	38	3	●	●
2.5	5	38	3		●
3	6	50	3	●	●
4	8	50	4	●	●
5	12	50	6	●	●
6	12	50	6	●	●
8	16	60	8	●	●
10	20	72	10	●	●
12	24	75	12	●	●
16	32	100	16	●	●
20	40	100	20	●	●

Code No. E107X-120°-Dc

Dc 0 -0.02	Lc mm	L mm	d h6	Bright E107-120°	AlTiN E107X-120°
1	2	38	3	●	●
2	4	38	3	●	●
3	6	50	3	●	●
4	8	50	4	●	●
5	12	50	6	●	●
6	12	50	6	●	●
8	16	60	8	●	●
10	20	72	10	●	●
12	24	75	12	●	●
16	32	100	16	●	●
20	40	100	20	●	●

E106X / Chamfering

Work Material		GR.1 Carbon Steel		GR.2 Low-alloyed Steel (~24HRC)		GR.3 Hi-alloyed Steel (~30HRC)		GR.4 Hardened Steel (30~38HRC)		GR.5 Hardened Steel (38~48HRC)		GR.8 Stainless Steel		GR.9 Cast Iron		GR.10 Aluminium	
Vc m/min		40~70		40~70		40~70		30~50		30~50		30~50		40~70		100~200	
Code No.	Dc	RPM (min-1)	Feed (mm/min)	RPM (min-1)	Feed (mm/min)	RPM (min-1)	Feed (mm/min)	RPM (min-1)	Feed (mm/min)	RPM (min-1)	Feed (mm/min)	RPM (min-1)	Feed (mm/min)	RPM (min-1)	Feed (mm/min)	RPM (min-1)	Feed (mm/min)
E106X-1	1	17,500	1050	17,500	1050	17,500	1050	9,550	286	9,550	286	9,550	286	17,500	1050	31,830	2,864
E106X-2	2.0	11,670	700	11,670	700	11,670	700	4,774	143	4,774	143	4,774	143	11,670	700	15,915	1,432
E106X-3	3	8,753	525	8,753	525	8,753	525	3,183	100	3,183	100	3,183	100	8,753	525	10,610	954
E106X-4	4.0	7,000	420	7,000	420	7,000	420	3,183	100	3,183	100	3,183	100	7,000	420	9,550	955
E106X-5	5	5,729	343	5,729	343	5,729	343	2,546	100	2,546	100	2,546	100	5,729	343	7,639	763
E106X-6	6.0	4,774	286	4,774	286	4,774	286	2,122	90	2,122	90	2,122	90	4,774	286	6,366	700
E106X-8	8	3,580	358	3,580	358	3,580	358	1,989	120	1,989	120	1,989	120	3,580	358	5,570	668
E106X-10	10.0	2,864	286	2,864	286	2,864	286	1,591	95	1,591	95	1,591	95	2,864	286	4,456	712
E106X-12	12	2,387	238	2,387	238	2,387	238	1,591	127	1,591	127	1,591	127	2,387	238	3,978	716
E106X-16	16.0	1,790	116	1,790	116	1,790	116	1,193	119	1,193	119	1,193	119	1,790	116	2,984	537
E106X-20	20	1,432	186	1,432	186	1,432	186	954	95	954	95	954	95	1,432	186	2,387	477

E107X / Chamfering / V groove machining

Work Material		GR.1 Carbon Steel		GR.2 Low-alloyed Steel (~24HRC)		GR.3 Hi-alloyed Steel (~30HRC)		GR.4 Hardened Steel (30~38HRC)		GR.5 Hardened Steel (38~48HRC)		GR.10 Aluminium	
Vc m/min		Ø0.5~0.8 48~50 Ø1.0~3.0 55~70 Ø3.1~20 90		Ø0.5~0.8 48~50 Ø1.0~3.0 55~70 Ø3.1~20 90		Ø0.5~0.8 48~50 Ø1.0~3.0 55~70 Ø3.1~20 90		Ø0.5~0.8 40 Ø1.0~3.0 45~65 Ø3.1~20 75		Ø0.5~0.8 40 Ø1.0~3.0 45~65 Ø3.1~20 75		Ø0.5~0.8 50 Ø1.0~3.0 60~95 Ø3.1~20 120	
Code No.	Dc	RPM (min-1)	Feed (mm/min)	RPM (min-1)	Feed (mm/min)	RPM (min-1)	Feed (mm/min)	RPM (min-1)	Feed (mm/min)	RPM (min-1)	Feed (mm/min)	RPM (min-1)	Feed (mm/min)
E107X-0.5	0.5	31,000	460	31,000	460	31,000	460	25,480	320	25,480	320	32,000	650
E107X-0.6	0.6	27,000	500	27,000	500	27,000	500	21,230	320	21,230	320	26,540	700
E107X-0.8	0.8	21,500	530	21,500	530	21,500	530	15,920	350	15,920	350	19,900	750
E107X-1.0	1	17,500	530	17,500	530	17,500	530	14,330	350	14,330	350	17,510	800
E107X-1.2	1.2	15,000	600	15,000	600	15,000	600	13,270	360	13,270	360	14,590	850
E107X-1.5	1.5	12,500	620	12,500	620	12,500	620	10,610	360	10,610	360	12,740	900
E107X-1.8	1.8	10,500	630	10,500	630	10,500	630	9,730	380	9,730	380	10,610	950
E107X-2.0	2	9,700	630	9,700	630	9,700	630	9,555	380	9,555	380	10,350	980
E107X-2.5	2.5	8,200	650	8,200	650	8,200	650	7,640	400	7,640	400	10,192	1,010
E107X-3.0	3	7,430	670	7,430	670	7,430	670	6,900	410	6,900	410	10,080	1,150
E107X-4.0	4	7,200	650	7,200	650	7,200	650	6,000	360	6,000	360	9,600	860
E107X-5.0	5	5,730	515	5,730	515	5,730	515	4,770	290	4,770	290	7,645	690
E107X-6.0	6	4,800	430	4,800	430	4,800	430	4,000	240	4,000	240	6,400	580
E107X-8.0	8	3,600	430	3,600	430	3,600	430	3,000	180	3,000	180	4,800	580
E107X-10.0	10	2,900	410	2,900	410	2,900	410	2,400	140	2,400	140	3,800	530
E107X-12.0	12	2,400	336	2,400	336	2,400	336	2,000	120	2,000	120	3,200	510
E107X-16.0	16	1,800	252	1,800	252	1,800	252	1,500	100	1,500	100	2,400	400
E107X-20.0	20	1,400	196	1,400	196	1,400	196	1,200	95	1,200	95	1,900	340
(mm)		≤ 0.3 D		≤ 0.3 D		≤ 0.3 D		≤ 0.3 D		≤ 0.3 D		≤ 0.3 D	

※ Pls. set up the feed speed under the 50% of conditions we described as above when you do the processing of V groove.

※ The standard of Ap(cutting depth) is 0.3d.

E108X / E109X

End Mills For Chamfering 60° / 90° / 120°

UMG
CarbideAlTiN
X-NaNo

Type of Operation



Code No. E108X-60°-Dc

Dc 0 -0.02	Lc mm	L mm	d h6	AlTiN E108X-60°
2	4	38	3	●
3	6	38	3	●
4	9	50	4	●
5	10	50	6	●
6	12	50	6	●
8	15	60	8	●
10	16	72	10	●
12	18	75	12	●
16	25	90	16	●
20	30	100	20	●

Work Material

P	H	M	K	N	S
●	●	○	●	●	○

P	Steel
---	-------

H	<38HRC Hardened Steel
---	--------------------------

H	<48HRC Hardened Steel
---	--------------------------

H	<56HRC Hardened Steel
---	--------------------------

M	Stainless Steel
---	-----------------

K	Cast Iron
---	-----------

N	Aluminium
---	-----------

N	Copper
---	--------

Feature of product:

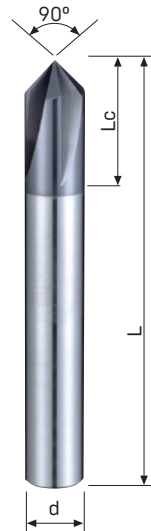
E108X-60° End Mills for
Chamfering 60°- 4 FlutesE109X-90° End Mills for
Chamfering 90°- 4 FlutesE109X-120° End Mills for
Chamfering 120°- 4 FlutesSuitable for drilling, tapping,
countersinking, NC Spot drilling
and frame milling.

Code No. E109X-90°-Dc

Dc 0 -0.02	Lc mm	L mm	d h6	AlTiN E109X-90°
2	4	38	3	●
3	6	38	3	●
4	9	50	4	●
5	10	50	6	●
6	12	50	6	●
8	15	60	8	●
10	16	72	10	●
12	18	75	12	●
16	25	90	16	●
20	30	100	20	●

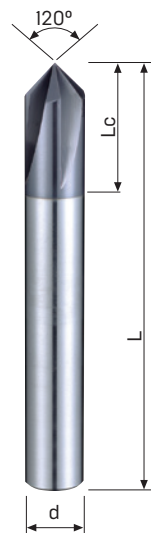

Code No. E109X-120°-Dc

Dc 0 -0.02	Lc mm	L mm	d h6	AlTiN E109X-120°
2	4	38	3	●
3	6	38	3	●
4	9	50	4	●
5	10	50	6	●
6	12	50	6	●
8	15	60	8	●
10	16	72	10	●
12	18	75	12	●
16	25	90	16	●
20	30	100	20	●

E108X / E109X / Chamfering

Work Material		GR.1 Carbon Steel		GR.2 Low-alloyed Steel (~24HRC)		GR.3 Hi-alloyed Steel (~30HRC)		GR.4 Hardened Steel (30-38HRC)		GR.5 Hardened Steel (38-48HRC)		GR.8 Stainless Steel		GR.9 Cast Iron		GR.10 Aluminium	
Vc m/min		40~70		40~70		40~70		30~50		30~50		30~50		40~70		100~200	
Code No.	Dc	RPM (min-1)	Feed (mm/min)	RPM (min-1)	Feed (mm/min)	RPM (min-1)	Feed (mm/min)	RPM (min-1)	Feed (mm/min)	RPM (min-1)	Feed (mm/min)	RPM (min-1)	Feed (mm/min)	RPM (min-1)	Feed (mm/min)	RPM (min-1)	Feed (mm/min)
E108X/E109X-2	2	11,670	700	11,670	700	11,670	700	4,774	143	4,774	143	4,774	143	11,670	700	15,915	1,432
E108X/E109X-3	3	8,753	525	8,753	525	8,753	525	3,183	100	3,183	100	3,183	100	8,753	525	10,610	954
E108X/E109X-4	4	7,000	420	7,000	420	7,000	420	3,183	100	3,183	100	3,183	100	7,000	420	9,550	955
E108X/E109X-5	5	5,729	343	5,729	343	5,729	343	2,546	100	2,546	100	2,546	100	5,729	343	7,639	763
E108X/E109X-6	6	4,774	286	4,774	286	4,774	286	2,122	90	2,122	90	2,122	90	4,774	286	6,366	700
E108X/E109X-8	8	3,580	358	3,580	358	3,580	358	1,989	120	1,989	120	1,989	120	3,580	358	5,570	668
E108X/E109X-10	10	2,864	286	2,864	286	2,864	286	1,591	95	1,591	95	1,591	95	2,864	286	4,456	712
E108X/E109X-12	12	2,387	238	2,387	238	2,387	238	1,591	127	1,591	127	1,591	127	2,387	238	3,978	716
E108X/E109X-16	16	1,790	116	1,790	116	1,790	116	1,193	119	1,193	119	1,193	119	1,790	116	2,984	537
E108X/E109X-20	20	1,432	186	1,432	186	1,432	186	954	95	954	95	954	95	1,432	186	2,387	477

E108X / V Groove Process

Work Material		GR.1 Carbon Steel		GR.2 Low-alloyed Steel (~24HRC)		GR.3 Hi-alloyed Steel (~30HRC)		GR.4 Hardened Steel (30-38HRC)		GR.5 Hardened Steel (38-48HRC)		GR.8 Stainless Steel		GR.9 Cast Iron		GR.10 Aluminium	
Vc m/min		40~70		40~70		40~70		20~50		20~50		20~50		40~70		100~200	
Code No.	Dc	RPM (min-1)	Feed (mm/min)	RPM (min-1)	Feed (mm/min)	RPM (min-1)	Feed (mm/min)	RPM (min-1)	Feed (mm/min)	RPM (min-1)	Feed (mm/min)	RPM (min-1)	Feed (mm/min)	RPM (min-1)	Feed (mm/min)	RPM (min-1)	Feed (mm/min)
E108X-2	2	11,670	700	11,670	700	11,670	700	4,774	143	4,774	143	4,774	143	11,670	700	15,915	1,432
E108X-3	3	8,753	525	8,753	525	8,753	525	3,183	100	3,183	100	3,183	100	8,753	525	10,610	954
E108X-4	4	7,000	420	7,000	420	7,000	420	3,183	100	3,183	100	3,183	100	7,000	420	9,550	955
E108X-5	5	5,729	343	5,729	343	5,729	343	2,546	100	2,546	100	2,546	100	5,729	343	7,639	763
E108X-6	6	4,774	286	4,774	286	4,774	286	2,122	90	2,122	90	2,122	90	4,774	286	6,366	700
E108X-8	8	3,580	358	3,580	358	3,580	358	1,989	120	1,989	120	1,989	120	3,580	358	5,570	668
E108X-10	10	2,864	286	2,864	286	2,864	286	1,591	95	1,591	95	1,591	95	2,864	286	4,456	712
E108X-12	12	2,387	238	2,387	238	2,387	238	1,591	127	1,591	127	1,591	127	2,387	238	3,978	716
E108X-16	16	1,790	116	1,790	116	1,790	116	1,193	119	1,193	119	1,193	119	1,790	116	2,984	537
E108X-20	20	1,432	186	1,432	186	1,432	186	954	95	954	95	954	95	1,432	186	2,387	477

※ Pls. set up the feed speed under the 50% of conditions we described as above when you do the processing of V groove.

※ The standard of Ad(cutting depth) is 0.3d.

1. Please work with good rigidity / high precision facilities and collet chuck.
2. Please choose proper cutting fluid.
3. The cutting data is reference value only. Please adjust it according to your real working conditions.
4. If RPM is lower the reference value, the Feed rate (fz) and RPM should be reduced by the same proportion.
5. If vibration occurs during cutting, please reduce cutting parameter.

E121HX / E123HX

End Mills for Chamfering 90°

MG Carbide **Bright AlTiCrN**



Type of Operation

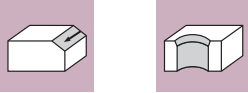

Work Material

P	H	M	K	N	S
○	●	○	○	○	○

P Steel

H <38HRC Hardened Steel

H <48HRC Hardened Steel

H <56HRC Hardened Steel

M Stainless Steel

K Cast Iron

N Aluminium

N Copper

Feature of product:

With Helix cutting edge design, reduce vibration during cutting process.

Sharp cutting edge could get better surface roughness and reduce burrs.

Apply AlTiCrN coating type to enhance tool life and gain better cutting efficiency of cutting tools.

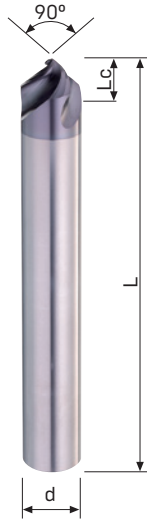

					Code No. E121HX-Dc	
Dc	D1	Lc	L	d	Bright E121	AlTiCrN E121HX
0 -0.02	mm	mm	mm	h6		
2	0.2	0.9	38	3	●	●
3	0.3	1.35	38	3	●	●
4	0.4	1.8	50	4	●	●
5	0.5	2.25	50	6	●	●
6	0.6	2.7	50	6	●	●
8	0.8	3.6	60	8	●	●
10	1	4.5	72	10	●	●
12	1.2	5.4	75	12	●	●
16	1.6	7.2	90	16	●	●
20	2	9	100	20	●	●

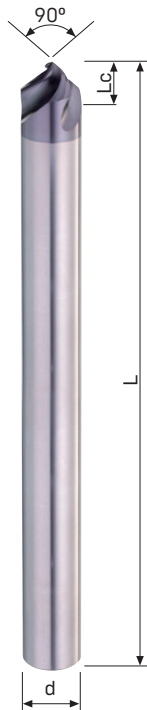

					Code No. E123HX-Dc	
Dc	D1	Lc	L	d	Bright E123	AlTiCrN E123HX
0 -0.02	mm	mm	mm	h6		
3	0.3	1.35	80	3	●	●
4	0.4	1.8	100	4	●	●
5	0.5	2.25	100	6	●	●
6	0.6	2.7	100	6	●	●
8	0.8	3.6	100	8	●	●
10	1	4.5	100	10	●	●
12	1.2	5.4	110	12	●	●
16	1.6	7.2	140	16	●	●
20	2	9	160	20	●	●

Chamfering

Work Material		GR.1 Carbon Steel		GR.2 Low-alloyed Steel (~24HRC)		GR.3 Hi-alloyed Steel (~30HRC)		GR.4 Hardened Steel (30-38HRC)		GR.5 Hardened Steel (38-48HRC)		GR.8 Stainless Steel		GR.9 Cast Iron		GR.15 Aluminium	
Vc m/min		60~90		60~90		50~80		30~50		30~50		30~50		60~90		100~200	
Code No.	Dc	RPM (min-1)	Feed (mm/min)	RPM (min-1)	Feed (mm/min)	RPM (min-1)	Feed (mm/min)	RPM (min-1)	Feed (mm/min)	RPM (min-1)	Feed (mm/min)	RPM (min-1)	Feed (mm/min)	RPM (min-1)	Feed (mm/min)	RPM (min-1)	Feed (mm/min)
E121HX/E123HX-2	2	10,500	945	10,500	630	9,550	573	4,780	215	4,780	215	4,780	215	10,500	945	24,000	2,160
E121HX/E123HX-3	3	8,500	893	6,900	725	6,400	672	3,180	239	3,180	239	3,180	239	8,500	893	16,000	1,680
E121HX/E123HX-4	4	5,500	660	5,500	660	5,200	624	2,800	252	2,800	252	2,800	252	5,500	660	11,940	1,612
E121HX/E123HX-5	5	4,500	675	4,500	675	4,150	623	2,300	242	2,300	242	2,300	242	4,500	675	9,550	1,576
E121HX/E123HX-6	6	3,700	666	3,700	666	3,450	621	2,120	254	2,120	254	2,120	254	3,700	666	8,000	1,440
E121HX/E123HX-8	8	3,180	763	3,180	763	2,780	667	1,600	240	1,600	240	1,600	240	3,180	763	6,000	1,440
E121HX/E123HX-10	10	2,550	765	2,550	765	2,230	669	1,270	229	1,270	229	1,270	229	2,550	765	4,800	1,440
E121HX/E123HX-12	12	2,380	714	2,380	714	1,990	597	1,200	252	1,200	252	1,200	252	2,380	714	4,000	1,200
E121HX/E123HX-16	16	1,800	594	1,800	594	1,500	495	1,000	240	1,000	240	1,000	240	1,800	594	3,000	990
E121HX/E123HX-20	20	1,400	546	1,400	546	1,200	468	800	192	800	192	800	192	1,400	546	2,400	936
(mm)		ap:0.3D		ap:0.3D		ap:0.3D		ap:0.3D		ap:0.3D		ap:0.3D		ap:0.3D		ap:0.3D	

1. Please work with good rigidity / high precision facilities and collet chuck.
2. Please choose proper cutting fluid.
3. The cutting data is reference value only. Please adjust it according to your real working conditions.
4. If RPM is lower the reference value, the Feed rate (fz) and RPM should be reduced by the same proportion.
5. If vibration occurs during cutting, please reduce cutting parameter.

E110HX

End Mills For Back and Front Chamfering 30° / 60° / 90° / 120°

MG
Carbide

AlTiCrN
HX

Type of Operation

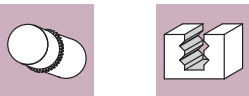
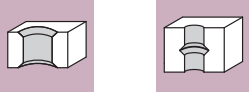

Work Material

P	H	M	K	N	S
●	●	○	○	○	○

P Steel

H <38HRC
Hardened Steel

H <48HRC
Hardened Steel

M Stainless Steel

K Cast Iron

N Aluminium

N Copper

S Titanium

S High Temp Alloys

Feature of product:

End Mills for Back and Front Chamfering / V-Groove End Mills
With great heat resistance,
applicable in high performance
processing.

Suitable for hardened steel,
stainless steel, carbon steel, non-
ferrous metals and other difficult-
to-cut materials.

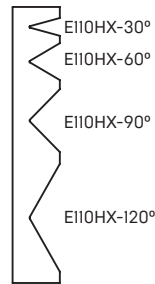
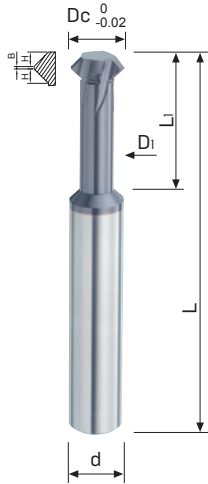

Code No. E110HX-30°-Dc

Dc	H	B	L	d	Li	Di	Z	AlTiCrN
$\begin{matrix} 0 \\ -0.02 \end{matrix}$	mm	mm	mm	h6	mm	mm	t	E110HX-30°
3	0.19	0.03	38	3	7.5	1.6	3	●
4	0.24	0.03	50	4	10	2.2	3	●
5	0.32	0.05	50	5	12.5	2.6	3	●
6	0.43	0.08	50	6	15	3.1	3	●
8	0.46	0.15	60	8	20	4.6	4	●
10	0.51	0.15	72	10	25	6.2	5	●
12	0.59	0.15	75	12	30	7.6	6	●

Code No. E110HX-60°-Dc

Dc	H	B	L	d	Li	Di	Z	AlTiCrN
$\begin{matrix} 0 \\ -0.02 \end{matrix}$	mm	mm	mm	h6	mm	mm	t	E110HX-60°
1	0.17	0.03	38	3	2.5	0.4	3	●
1.5	0.23	0.03	38	3	3.8	0.7	3	●
2	0.29	0.05	38	3	5	1	3	●
2.5	0.35	0.05	38	3	6.3	1.3	3	●
3	0.4	0.08	38	3	7.5	1.6	3	●
3.5	0.46	0.08	50	4	8.8	1.9	3	●
4	0.52	0.1	50	4	10	2.2	3	●
4.5	0.64	0.15	50	5	11.3	2.3	3	●
5	0.69	0.2	50	5	12.5	2.6	3	●
5.5	0.75	0.2	50	6	13.8	2.9	3	●
6	0.92	0.2	50	6	15	3.1	3	●
8	0.98	0.2	60	8	20	4.6	4	●
10	1.1	0.2	72	10	25	6.2	5	●
12	1.27	0.2	75	12	30	7.6	6	●

Code No. E110HX-90°-Dc

Dc	H	B	L	d	Li	Di	Z	AlTiCrN
$\begin{matrix} 0 \\ -0.02 \end{matrix}$	mm	mm	mm	h6	mm	mm	t	E110HX-90°
1	0.3	0.05	38	3	2.5	0.4	3	●
1.5	0.4	0.08	38	3	3.8	0.7	3	●
2	0.5	0.1	38	3	5	1	3	●
2.5	0.6	0.15	38	3	6.3	1.3	3	●
3	0.7	0.2	38	3	7.5	1.6	3	●
3.5	0.8	0.2	50	4	8.8	1.9	3	●
4	0.9	0.2	50	4	10	2.2	3	●
4.5	1.1	0.2	50	5	11.3	2.3	3	●
5	1.2	0.2	50	5	12.5	2.6	3	●
5.5	1.3	0.2	50	6	13.8	2.9	3	●
6	1.6	0.2	50	6	15	3.1	3	●
8	1.7	0.2	60	8	20	4.6	4	●
10	1.9	0.2	72	10	25	6.2	5	●
12	2.2	0.2	75	12	30	7.6	6	●

Code No. E110HX-120°-Dc

Dc	H	B	L	d	Li	Di	Z	AlTiCrN
$\begin{matrix} 0 \\ -0.02 \end{matrix}$	mm	mm	mm	h6	mm	mm	t	E110HX-120°
3	1.21	0.2	38	3	7.5	1.6	3	●
4	1.56	0.2	50	4	10	2.2	3	●
5	2.08	0.2	50	5	12.5	2.6	3	●
6	2.77	0.2	50	6	15	3.1	3	●
8	2.94	0.2	60	8	20	4.6	4	●
10	3.29	0.2	72	10	25	6.2	5	●
12	3.81	0.2	75	12	30	7.6	6	●

Chamfering

Work Material		GR.1 Carbon Steel		GR.2 Low-alloyed Steel (~24HRC)		GR.4 Hardened Steel (30-38HRC)		GR.8 Stainless Steel		GR.9 Cast Iron		GR.15 Titanium		GR.10 Aluminium		GR.10 Aluminium	
Vc m/min		30~60		25~70		15~40		25~50		30~80		15~30		25~80		100~200	
Code No.	Dc	RPM (min-1)	Feed (mm/min)	RPM (min-1)	Feed (mm/min)	RPM (min-1)	Feed (mm/min)	RPM (min-1)	Feed (mm/min)	RPM (min-1)	Feed (mm/min)	RPM (min-1)	Feed (mm/min)	RPM (min-1)	Feed (mm/min)	RPM (min-1)	Feed (mm/min)
E110HX-1	1	14,323	2,148	14,323	2,148	7,957	477	11,140	835	14,323	2,148	4,774	286	14,323	2,148	31,830	4,700
E110HX-1.5	1.5	9,549	1,430	9,549	1,430	5300	318	7,427	557	9,549	1,430	3,183	190	9,549	1,430	21,220	3,183
E110HX-2.0	2	7,161	1,280	7,161	1,280	3978	238	5,570	417	7,161	1,280	2,387	143	7,161	1,280	15,915	2,387
E110HX-2.5	2.5	5,729	1,030	5,729	1,030	3183	238	4,456	400	5,729	1,030	1,909	114	5,729	1,030	12,732	1,900
E110HX-3	3	4,774	1,000	4,774	1,000	2652	198	3,713	334	4,774	1,000	1,591	100	4,774	1,000	10,610	1,591
E110HX-3.5	3.5	4,547	818	4,547	818	2728	204	3,637	381	4,547	818	1,818	136	4,547	818	9,094	1,364
E110HX-4	4	3,978	835	3,978	835	2387	214	3,183	334	3,978	835	1,591	119	3,978	835	9,549	1,432
E110HX-4.5	4.5	3,536	742	3,536	742	2122	190	2,828	296	3,536	742	1,414	127	3,536	742	8,848	1,327
E110HX-5	5	3,183	763	3,183	763	1910	200	2,546	305	3,183	763	1,273	114	3,183	763	7,639	1,145
E110HX-5.5	5.5	3,100	651	3,100	651	1736	182	2,314	277	3,100	651	1,157	121	3,100	651	6,944	1,041
E110HX-6	6	2,917	612	2,917	612	1856	194	2,387	286	2,917	612	1,061	111	2,917	612	6,366	954
E110HX-8	8	2,188	612	2,188	612	1392	194	1,790	286	2,188	612	994	159	2,188	612	5,570	1,114
E110HX-10	10	1,750	612	1,750	612	1114	222	1,432	286	1,750	612	795	159	1,750	612	4,456	1,114
E110HX-12	12	1,591	668	1,591	668	928	250	1,193	286	1,591	668	663	159	1,591	668	3,713	1,114

1. Please work with good rigidity / high precision facilities and collet chuck.
2. Please choose proper cutting fluid.
3. The cutting data is reference value only. Please adjust it according to your real working conditions.
4. If RPM is lower the reference value, the Feed rate [fz] and RPM should be reduced by the same proportion.
5. If vibration occurs during cutting, please reduce cutting parameter.

E120HX

End Mills For Back and Front Chamfering 30° / 60° / 90° / 120°

MG
Carbide

AlTiCrN
HX



Type of Operation

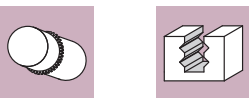
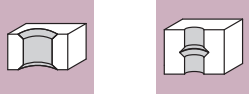

Work Material

P	H	M	K	N	S
●	●	○	○	○	○

P Steel

H <38HRC
Hardened Steel

H <48HRC
Hardened Steel

M Stainless Steel

K Cast Iron

N Aluminium

N Copper

S Titanium

S High Temp Alloys

Feature of product:

End Mills for Back and Front Chamfering / V-Groove End Mills
With great heat resistance,
applicable in high performance
processing.

Suitable for hardened steel,
stainless steel, carbon steel, non-
ferrous metals and other difficult-
to-cut materials.

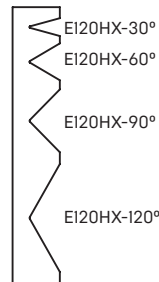
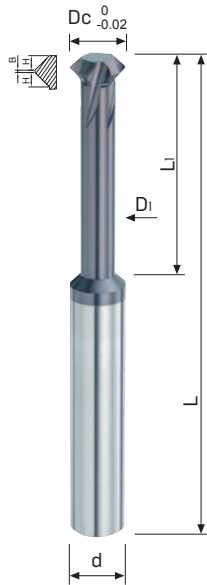

Code No. E120HX-30°-Dc

Dc 0 -0.02	H mm	B mm	L mm	d h6	Li mm	Di mm	Z t	AlTiCrN E120HX-30°
3	0.19	0.03	50	3	12	1.6	3	●
4	0.24	0.03	50	4	16	2.2	3	●
5	0.32	0.05	50	5	20	2.6	3	●
6	0.43	0.08	60	6	24	3.1	3	●
8	0.46	0.15	70	8	32	4.6	4	●
10	0.51	0.15	80	10	40	6.2	5	●
12	0.59	0.15	90	12	48	7.6	6	●

Code No. E120HX-60°-Dc

Dc 0 -0.02	H mm	B mm	L mm	d h6	Li mm	Di mm	Z t	AlTiCrN E120HX-60°
3	0.4	0.08	50	3	12	1.6	3	●
3.5	0.46	0.08	50	4	14	1.9	3	●
4	0.52	0.1	50	4	16	2.2	3	●
4.5	0.64	0.15	50	5	18	2.3	3	●
5	0.69	0.2	50	5	20	2.6	3	●
5.5	0.75	0.2	60	6	22	2.9	3	●
6	0.92	0.2	60	6	24	3.1	3	●
8	0.98	0.2	70	8	32	4.6	4	●
10	1.1	0.2	80	10	40	6.2	5	●
12	1.27	0.2	90	12	48	7.6	6	●

Code No. E120HX-90°-Dc

Dc 0 -0.02	H mm	B mm	L mm	d h6	Li mm	Di mm	Z t	AlTiCrN E120HX-90°
3	0.7	0.2	50	3	12	1.6	3	●
3.5	0.8	0.2	50	4	14	1.9	3	●
4	0.9	0.2	50	4	16	2.2	3	●
4.5	1.1	0.2	50	5	18	2.3	3	●
5	1.2	0.2	50	5	20	2.6	3	●
5.5	1.3	0.2	60	6	22	2.9	3	●
6	1.6	0.2	60	6	24	3.1	3	●
8	1.7	0.2	70	8	32	4.6	4	●
10	1.9	0.2	80	10	40	6.2	5	●
12	2.2	0.2	90	12	48	7.6	6	●

Code No. E120HX-120°-Dc

















Dc 0 -0.02	H mm	B mm	L mm	d h6	Li mm	Di mm	Z t	AlTiCrN E120HX-120°
3	1.21	0.2	50	3	12	1.6	3	●
4	1.56	0.2	50	4	16	2.2	3	●
5	2.08	0.2	50	5	20	2.6	3	●
6	2.77	0.2	60	6	24	3.1	3	●
8	2.94	0.2	70	8	32	4.6	4	●
10	3.29	0.2	80	10	40	6.2	5	●
12	3.81	0.2	90	12	48	7.6	6	●

Chamfering

Work Material		GR.1 Carbon Steel		GR.2 Low-alloyed Steel (~24HRC)		GR.4 Hardened Steel (30-38HRC)		GR.8 Stainless Steel		GR.9 Cast Iron		GR.15 Titanium		GR.10 Aluminium		GR.10 Aluminium	
Vc m/min		30~60		25~70		15~40		25~50		30~80		15~30		25~80		100~200	
Code No.	Dc	RPM (min-1)	Feed (mm/min)	RPM (min-1)	Feed (mm/min)	RPM (min-1)	Feed (mm/min)	RPM (min-1)	Feed (mm/min)	RPM (min-1)	Feed (mm/min)	RPM (min-1)	Feed (mm/min)	RPM (min-1)	Feed (mm/min)	RPM (min-1)	Feed (mm/min)
E120HX-3	3	4,774	1,000	4,774	1,000	2,652	198	3,713	334	4,774	1,000	1,591	100	4,774	1,000	10,610	1,591
E120HX-3.5	3.5	4,547	818	4,547	818	2,728	204	3,637	381	4,547	818	1,818	136	4,547	818	9,094	1,364
E120HX-4	4	3,978	835	3,978	835	2,387	214	3,183	334	3,978	835	1,591	119	3,978	835	9,549	1,432
E120HX-4.5	4.5	3,536	742	3,536	742	2,122	190	2,828	296	3,536	742	1,414	127	3,536	742	8,848	1,327
E120HX-5	5	3,183	763	3,183	763	1,910	200	2,546	305	3,183	763	1,273	114	3,183	763	7,639	1,145
E120HX-5.5	5.5	3,100	651	3,100	651	1,736	182	2,314	277	3,100	651	1,157	121	3,100	651	6,944	1,041
E120HX-6	6	2,917	612	2,917	612	1,856	194	2,387	286	2,917	612	1,061	111	2,917	612	6,366	954
E120HX-8	8	2,188	612	2,188	612	1,392	194	1,790	286	2,188	612	994	159	2,188	612	5,570	1,114
E120HX-10	10	1,750	612	1,750	612	1,114	222	1,432	286	1,750	612	795	159	1,750	612	4,456	1,114
E120HX-12	12	1,591	668	1,591	668	928	250	1,193	286	1,591	668	663	159	1,591	668	3,713	1,114

1. Please work with good rigidity / high precision facilities and collet chuck.
2. Please choose proper cutting fluid.
3. The cutting data is reference value only. Please adjust it according to your real working conditions.
4. If RPM is lower the reference value, the Feed rate (fz) and RPM should be reduced by the same proportion.
5. If vibration occurs during cutting, please reduce cutting parameter.

Universal Finishing End Mills

Page	91	93	95	97	99	101
Apperance						
Code No	E122X	E125X E127X	E162TX E163TX	E124X	E126X E128X	E164TX E165TX
Carbide	MG Carbide	MG Carbide	MG Carbide	MG Carbide	MG Carbide	UMG Carbide
Coating	AlTiN X-NaNo	AlTiN X-NaNo	AlTiSiN TX	AlTiN X-NaNo	AlTiN X-NaNo	AlTiSiN TX
Helix Angle	 35°	 35°	 35°	 35°	 35°	 35°
No.of Flutes	 2	 2	 2	 4	 4	 4

ASIA

103

105

107



E158TX
E159TX

E168TX
E169TX

E166TX
E167TX

SMG
Carbide

SMG
Carbide

SMG
Carbide

AlTiSiN
TX

AlTiSiN
TX

AlTiSiN
TX



Universal End Mills

Code No. E122X-Dc

MG
Carbide

AlTiN
X-NaNo

Type of Operation

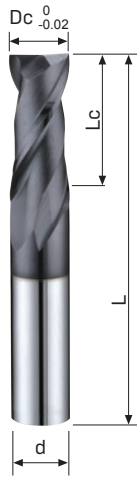

MG Carbide					AlTiN X-NaNo					MG Carbide					AlTiN X-NaNo				
Dc ₀ -0.02	Lc	L	d	AITiN E122X	Dc ₀ -0.02	Lc	L	d	AITiN E122X	Dc ₀ -0.02	Lc	L	d	AITiN E122X	Dc ₀ -0.02	Lc	L	d	AITiN E122X
0.1	0.3	50	4	●	6.9	20	60	8	●	13.9	26	80	12	●	0.1	0.3	50	4	●
0.2	0.5	50	4	●	7	20	60	8	●	14	32	90	16	●	0.2	0.5	50	4	●
0.3	0.8	50	4	●	7.1	20	60	8	●	14.1	32	90	16	●	0.3	0.8	50	4	●
0.4	1	50	4	●	7.2	20	60	8	●	14.2	32	90	16	●	0.4	1	50	4	●
0.5	1.2	50	4	●	7.3	20	60	8	●	14.3	32	90	16	●	0.5	1.2	50	4	●
0.6	1.5	50	4	●	7.4	20	60	8	●	14.4	32	90	16	●	0.6	1.5	50	4	●
0.7	1.8	50	4	●	7.5	20	60	8	●	14.5	32	90	16	●	0.7	1.8	50	4	●
0.8	2	50	4	●	7.6	20	60	8	●	14.6	32	90	16	●	0.8	2	50	4	●
0.9	2.5	50	4	●	7.7	20	60	8	●	14.7	32	90	16	●	0.9	2.5	50	4	●
1	3	50	4	●	7.8	20	60	8	●	14.8	32	90	16	●	1	3	50	4	●
1.1	3	50	4	●	7.9	20	60	8	●	14.9	32	90	16	●	1.1	3	50	4	●
1.2	4	50	4	●	8	20	60	8	●	15	32	90	16	●	1.2	4	50	4	●
1.3	4	50	4	●	8.1	20	72	10	●	15.1	38	100	16	●	1.3	4	50	4	●
1.4	4	50	4	●	8.2	20	72	10	●	15.2	38	100	16	●	1.4	4	50	4	●
1.5	5	50	4	●	8.3	20	72	10	●	15.3	38	100	16	●	1.5	5	50	4	●
1.6	5	50	4	●	8.4	20	72	10	●	15.4	38	100	16	●	1.6	5	50	4	●
1.7	5	50	4	●	8.5	20	72	10	●	15.5	38	100	16	●	1.7	5	50	4	●
1.8	5	50	4	●	8.6	22	72	10	●	15.6	38	100	16	●	1.8	5	50	4	●
1.9	5	50	4	●	8.7	22	72	10	●	15.7	38	100	16	●	1.9	5	50	4	●
2	6	50	4	●	8.8	22	72	10	●	15.8	38	100	16	●	2	6	50	4	●
2.1	6	50	4	●	8.9	22	72	10	●	15.9	38	100	16	●	2.1	6	50	4	●
2.2	6	50	4	●	9	22	72	10	●	16	38	100	16	●	2.2	6	50	4	●
2.3	6	50	4	●	9.1	22	72	10	●	16.1	38	100	20	●	2.3	6	50	4	●
2.4	8	50	4	●	9.2	22	72	10	●	16.2	38	100	20	●	2.4	8	50	4	●
2.5	8	50	4	●	9.3	22	72	10	●	16.3	38	100	20	●	2.5	8	50	4	●
2.6	8	50	4	●	9.4	22	72	10	●	16.4	38	100	20	●	2.6	8	50	4	●
2.7	8	50	4	●	9.5	22	72	10	●	16.5	38	100	20	●	2.7	8	50	4	●
2.8	8	50	4	●	9.6	22	72	10	●	16.6	38	100	20	●	2.8	8	50	4	●
2.9	8	50	4	●	9.7	22	72	10	●	16.7	38	100	20	●	2.9	8	50	4	●
3A	8	50	4	●	9.8	22	72	10	●	16.8	38	100	20	●	3A	8	50	4	●
4A	11	50	4	●	9.9	22	72	10	●	16.9	38	100	20	●	4A	11	50	4	●
3	8	50	6	●	10	22	72	10	●	17	38	100	20	●	3	8	50	6	●
3.1	10	50	6	●	10.1	22	75	12	●	17.1	38	100	20	●	3.1	10	50	6	●
3.2	10	50	6	●	10.2	22	75	12	●	17.2	38	100	20	●	3.2	10	50	6	●
3.3	10	50	6	●	10.3	22	75	12	●	17.3	38	100	20	●	3.3	10	50	6	●
3.4	10	50	6	●	10.4	22	75	12	●	17.4	38	100	20	●	3.4	10	50	6	●
3.5	10	50	6	●	10.5	22	75	12	●	17.5	38	100	20	●	3.5	10	50	6	●
3.6	10	50	6	●	10.6	26	75	12	●	17.6	38	100	20	●	3.6	10	50	6	●
3.7	10	50	6	●	10.7	26	75	12	●	17.7	38	100	20	●	3.7	10	50	6	●
3.8	11	50	6	●	10.8	26	75	12	●	17.8	38	100	20	●	3.8	11	50	6	●
3.9	11	50	6	●	10.9	26	75	12	●	17.9	38	100	20	●	3.9	11	50	6	●
4	11	50	6	●	11	26	75	12	●	18	38	100	20	●	4	11	50	6	●
4.1	11	50	6	●	11.1	26	75	12	●	18.1	38	100	20	●	4.1	11	50	6	●
4.2	11	50	6	●	11.2	26	75	12	●	18.2	38	100	20	●	4.2	11	50	6	●
4.3	11	50	6	●	11.3	26	75	12	●	18.3	38	100	20	●	4.3	11	50	6	●
4.4	11	50	6	●	11.4	26	75	12	●	18.4	38	100	20	●	4.4	11	50	6	●
4.5	11	50	6	●	11.5	26	75	12	●	18.5	38	100	20	●	4.5	11	50	6	●
4.6	11	50	6	●	11.6	26	75	12	●	18.6	38	100	20	●	4.6	11	50	6	●
4.7	11	50	6	●	11.7	26	75	12	●	18.7	38	100	20	●	4.7	11	50	6	●
4.8	13	50	6	●	11.8	26	75	12	●	18.8	38	100	20	●	4.8	13	50	6	●
4.9	13	50	6	●	11.9	26	75	12	●	18.9	38	100	20	●	4.9	13	50	6	●
5	13	50	6	●	12	26	75	12	●	19	38	100	20	●	5	13	50	6	●
5.1	13	50	6	●	12.1	26	80	12	●	19.1	38	100	20	●	5.1	13	50	6	●
5.2	13	50	6	●	12.2	26	80	12	●	19.2	38	100	20	●	5.2	13	50	6	●
5.3	13	50	6	●	12.3	26	80	12	●	19.3	38	100	20	●	5.3	13	50	6	●
5.4	13	50	6	●	12.4	26	80	12	●	19.4	38	100	20	●	5.4	13	50	6	●
5.5	13	50	6	●	12.5	26	80	12	●	19.5	38	100	20	●	5.5	13	50	6	●
5.6	16	50	6	●	12.6	26	80	12	●	19.6	38	100	20	●	5.6	16	50	6	●
5.7	16	50	6	●	12.7	26	80	12	●	19.7	38	100	20	●	5.7	16	50	6	●
5.8	16	50	6	●	12.8	26	80	12	●	19.8	38	100	20	●	5.8	16	50	6	●
5.9	16	50	6	●	12.9	26	80	12	●	19.9	38	100	20	●	5.9	16	50	6	●
6	16	50	6	●	13	26	80	12	●	20	38	100	20	●	6	16	50	6	●
6.1	16	60	8	●	13.1	26	80	12	●	1/8 3.175	8	50	6	●	6.1	16	60	8	●
6.2	16	60	8	●	13.2	26	80	12	●	3/16 4.760	12	50	6	●	6.2	16	60	8	●
6.3	16	60	8	●	13.3	26	80	12	●	1/4 6.350	18	60	8	●	6.3	16	60	8	●
6.4	16	60	8	●	13.4	26	80	12	●	5/16 7.940	20	60	8	●	6.4	16	60	8	●
6.5	16	60	8	●	13.5	26	80	12	●	3/8 9.525	22	72	10	●	6.5	16	60	8	●
6.6	20	60	8	●	13.6	26	80	12	●	1/2 12.700	26	75	12	●	6.6	20	60	8	●
6.7	20	60	8	●	13.7	26	80	12	●	5/8 15.880	38	100	16	●	6.7	20	60	8	●
6.8	20	60	8	●	13.8	26	80	12	●	3/4 19.050	38	100	20	●	6.8	20	60	8	●

Feature of product:

Universal End Mills- 2 Flutes
Excellent surface cutting effect
on work piece.

Nano multilayer coating enable to
enhance wear resistance.

Suitable for general cutting
process and enable to use for drill
milling.

Slotting

Work Material		GR.1 Carbon Steel		GR.2 Low-alloyed Steel (~24HRC)		GR.3 Hi-alloyed Steel (~30HRC)		GR.4 Hardened Steel (30~38HRC)		GR.5 Hardened Steel (38~48HRC)		GR.8 Stainless Steel		GR.9 Cast Iron		GR.11 Copper	
Vc m/min		Ø0.1~0.7 20~50 Ø0.8~3.0 55~65 Ø3.1~20 65~80		Ø0.1~0.7 20~50 Ø0.8~3.0 55~65 Ø3.1~20 65~80		Ø0.1~0.7 20~50 Ø0.8~3.0 55~65 Ø3.1~20 65~80		Ø0.1~0.7 20~40 Ø0.8~3.0 40~50 Ø3.1~20 55~60		Ø0.1~0.7 20~35 Ø0.8~3.0 35~45 Ø3.1~20 45~50		Ø0.1~0.7 20~40 Ø0.8~3.0 40~50 Ø3.1~20 55~60		Ø0.1~0.7 20~50 Ø0.8~3.0 55~65 Ø3.1~20 80~100		Ø0.1~0.7 30~95 Ø0.8~20 125~150	
Code No.	Dc	RPM (min-1)	Feed (mm/min)	RPM (min-1)	Feed (mm/min)	RPM (min-1)	Feed (mm/min)	RPM (min-1)	Feed (mm/min)	RPM (min-1)	Feed (mm/min)	RPM (min-1)	Feed (mm/min)	RPM (min-1)	Feed (mm/min)	RPM (min-1)	Feed (mm/min)
E122X-0.1	0.1	35,000	60	35,000	60	35,000	60	35,000	50	35,000	20	35,000	50	35,000	60	50,000	100
E122X-0.2	0.2	32,000	85	32,000	85	32,000	80	32,000	75	32,000	30	32,000	75	32,000	85	50,000	140
E122X-0.3	0.3	32,000	100	32,000	100	32,000	90	32,000	80	32,000	55	32,000	80	32,000	100	50,000	170
E122X-0.4	0.4	32,000	110	32,000	110	32,000	100	32,000	90	27,500	60	32,000	90	32,000	110	50,000	190
E122X-0.5	0.5	31,000	115	31,000	115	31,000	150	25,000	90	22,000	60	25,000	90	31,000	115	50,000	200
E122X-0.6	0.6	27,000	118	27,000	118	27,000	105	19,500	90	17,000	60	19,500	90	27,000	118	50,000	230
E122X-0.8	0.8	21,500	120	21,500	120	21,500	108	15,500	90	13,500	60	15,500	90	21,500	120	50,000	290
E122X-1	1	17,500	120	17,500	120	17,500	108	12,500	90	11,000	60	12,500	90	17,500	120	47,500	300
E122X-1.2	1.2	15,000	118	15,000	118	15,000	106	10,500	90	9,300	60	10,500	90	15,000	118	40,500	300
E122X-1.5	1.5	12,500	122	12,500	122	12,500	110	8,900	90	7,900	60	8,900	90	12,500	122	32,000	300
E122X-1.8	1.8	10,500	125	10,500	125	10,500	115	7,500	90	6,800	60	7,500	90	10,500	125	28,000	300
E122X-2	2	9,700	130	9,700	130	9,700	117	7,000	90	6,300	70	7,000	90	9,700	130	24,000	300
E122X-2.5	2.5	8,200	155	8,200	155	8,200	140	6,100	90	5,300	70	6,100	90	8,200	155	20,000	350
E122X-3	3	6,900	170	6,900	170	6,900	153	5,300	100	4,400	70	5,300	100	8,493	200	16,000	400
E122X-3.5	3.5	6,000	190	6,000	190	6,000	190	4,700	100	3,860	70	4,700	100	7,280	210	13,650	415
E122X-4	4	5,400	210	5,400	210	5,400	190	4,200	120	3,500	90	4,200	120	6,370	215	12,000	430
E122X-4.5	4.5	4,850	240	4,850	240	4,850	240	3,800	120	3,200	90	3,800	120	5,660	220	10,600	465
E122X-5	5	4,500	265	4,500	265	4,500	240	3,500	130	3,000	95	3,500	130	5,096	225	9,500	500
E122X-5.5	5.5	4,200	268	4,200	268	4,200	268	3,200	130	2,720	95	3,200	130	4,630	225	8,700	510
E122X-6	6	4,000	270	4,000	270	4,000	243	2,900	130	2,500	100	2,900	130	4,247	230	7,900	520
E122X-7	7	3,500	265	3,500	265	3,500	265	2,550	120	2,200	100	2,550	120	3,640	235	6,900	520
E122X-8	8	3,000	265	3,000	265	3,000	265	2,200	120	1,900	100	2,200	120	3,185	235	5,900	520
E122X-9	9	2,700	260	2,700	260	2,700	260	1,950	120	1,650	95	1,950	120	2,830	215	5,300	500
E122X-10	10	2,400	255	2,400	255	2,400	255	1,700	120	1,400	95	1,700	120	2,548	215	4,700	500
E122X-11	11	2,200	250	2,200	250	2,200	250	1,550	120	1,300	95	1,550	120	2,310	215	4,350	500
E122X-12	12	2,000	246	2,000	246	2,000	246	1,400	120	1,200	95	1,400	120	2,123	215	4,000	500
E122X-13	13	1,850	240	1,850	240	1,850	240	1,300	90	1,100	80	1,300	90	1,960	210	3,750	400
E122X-14	14	1,700	240	1,700	240	1,700	240	1,200	90	1,000	80	1,200	90	1,820	210	3,500	400
E122X-15	15	1,600	220	1,600	220	1,600	220	1,050	90	900	80	1,050	90	1,700	210	3,250	400
E122X-16	16	1,500	200	1,500	200	1,500	200	1,100	90	800	80	1,100	90	1,593	210	3,000	400
E122X-17	17	1,400	190	1,400	190	1,400	190	1,000	90	750	70	1,000	90	1,500	205	2,850	350
E122X-18	18	1,300	180	1,300	180	1,300	180	900	90	700	70	900	90	1,416	205	2,700	350
E122X-19	19	1,100	165	1,100	165	1,100	165	850	90	650	60	850	90	1,340	205	2,550	300
E122X-20	20	1,200	155	1,200	155	1,200	155	800	90	600	60	800	90	1,274	205	2,400	300
		ap:<1 0.1D <3 0.3D ≥3 0.5D		ap:<1 0.1D <3 0.3D ≥3 0.5D		ap:<1 0.1D <3 0.3D ≥3 0.5D		ap:<1 0.1D <3 0.3D ≥3 0.5D		ap:<1 0.01D <3 0.02D ≥3 0.05D		ap:<1 0.1D <3 0.3D ≥3 0.5D		ap:<1 0.1D <3 0.3D ≥3 0.5D		ap:<1 0.1D <3 0.3D ≥3 0.5D	

1. Please work with good rigidity / high precision facilities and collet chuck.
2. Please choose proper cutting fluid.
3. The cutting data is reference value only. Please adjust it according to your real working conditions.
4. If RPM is lower the reference value, the Feed rate (fz) and RPM should be reduced by the same proportion.
5. If vibration occurs during cutting, please reduce cutting parameter.

E125X / E127X

Universal End Mills

MG Carbide **AlTiN X-NaNo**



Type of Operation

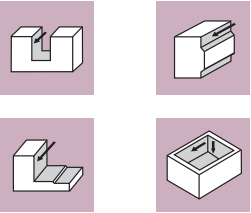

Work Material

P	H	M	K	N	S
●	●	○	●	○	○

P Steel

H <38HRC Hardened Steel

H <48HRC Hardened Steel

M Stainless Steel

K Cast Iron

N Copper

Feature of product:

Universal End Mills with Long Length- 2 Flutes

Nano multilayer coating enable to enhance wear resistance.

Suitable for general cutting process, extended length enable to work on deeper work piece with excellent cutting surface.

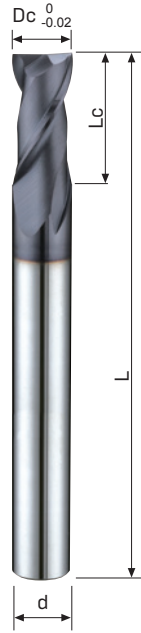

Code No. E125X-Dc

Dc	Lc	L	d	AlTiN
$0_{-0.02}$	mm	mm	h6	E125X
3	12	70	6	●
4	15	70	6	●
5	20	80	6	●
6	20	80	6	●
7	25	100	8	●
8	25	100	8	●
9	30	100	10	●
10	30	100	10	●
11	35	110	12	●
12	40	110	12	●
14	40	120	16	●
16	50	140	16	●
20	60	160	20	●

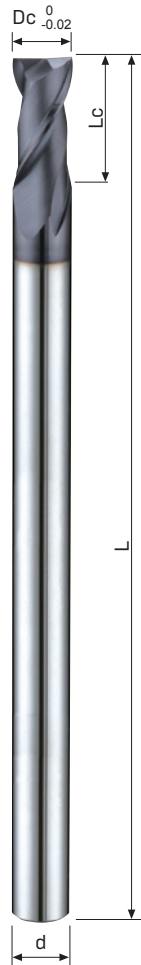

Code No. E127X-Dc

Dc	Lc	L	d	AlTiN
$0_{-0.02}$	mm	mm	h6	E127X
3	12	80	4	●
4	15	80	4	●
5	20	100	6	●
6	20	100	6	●
8	25	130	8	●
10	30	160	10	●
12	40	180	12	●
16	50	210	16	●
20	60	210	20	●

Slotting

Work Material		GR.1 Carbon Steel		GR.2 Low-alloyed Steel (~24HRC)		GR.3 Hi-alloyed Steel (~30HRC)		GR.4 Hardened Steel (30~38HRC)		GR.5 Hardened Steel (38~48HRC)		GR.9 Cast Iron	
Vc m/min		60		60		50		40		30		80	
Code No.	Dc	RPM (min-1)	Feed (mm/min)	RPM (min-1)	Feed (mm/min)	RPM (min-1)	Feed (mm/min)	RPM (min-1)	Feed (mm/min)	RPM (min-1)	Feed (mm/min)	RPM (min-1)	Feed (mm/min)
E125X/E127X-3	3	6,050	140	6,050	140	5,200	120	4,200	80	3,000	65	6,800	140
E125X/E127X-4	4	4,860	149	4,860	149	3,800	120	3,200	90	2,160	65	4,860	149
E125X/E127X-5	5	4,050	162	4,050	162	3,050	120	2,600	90	1,800	75	4,050	162
E125X/E127X-6	6	3,250	162	3,250	162	2,600	120	2,100	90	1,440	75	3,250	162
E125X-7	7	2,850	162	2,850	162	2,275	130	1,850	100	1,260	75	2,850	162
E125X/E127X-8	8	2,450	162	2,450	162	1,950	140	1,600	100	1,080	75	2,450	162
E125X-9	9	2,200	162	2,200	162	1,750	140	1,450	110	970	75	2,200	162
E125X/E127X-10	10	1,950	162	1,950	162	1,550	140	1,300	110	870	75	1,950	162
E125X-11	11	1,780	162	1,780	162	1,420	140	1,200	110	790	75	1,780	162
E125X/E127X-12	12	1,620	162	1,620	162	1,300	140	1,080	110	720	75	1,620	162
E125X-14	14	1,650	180	1,650	180	1,200	150	1,000	118	720	80	1,650	180
E125X/E127X-16	16	1,400	198	1,400	198	1,900	160	900	125	630	90	1,400	198
E125X/E127X-20	20	1,080	198	1,080	198	870	160	720	125	480	90	1,080	198
(mm)		ap:0.3D		ap:0.3D		ap:0.3D		ap:0.2D		ap:0.2D		ap:0.3D	

※ Notice: E127X is Long Length series End Mills. Please adjust the parameter according

1. Please work with good rigidity / high precision facilities and collet chuck.
2. Please choose proper cutting fluid.
3. The cutting data is reference value only. Please adjust it according to your real working conditions.
4. If RPM is lower the reference value, the Feed rate [fz] and RPM should be reduced by the same proportion.
5. If vibration occurs during cutting, please reduce cutting parameter.

E162TX / E163TX

Universal End Mills

UMG Carbide **AlTiSiN TX**

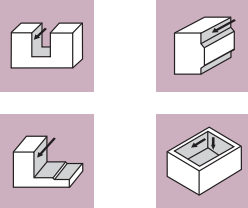
**Type of Operation****Work Material**

P	H	M	K	N	S
●	●	●	●	●	●

P Steel

H <38HRC Hardened Steel

H <48HRC Hardened Steel

H <56HRC Hardened Steel

Feature of product:

Universal End Mills- 2 Flutes
Using UMG carbide material and coated with high wear resistance TX coating enable to enhance tool life.

Suitable for high hardness material finishing, general cutting process and enable to use for drill milling.

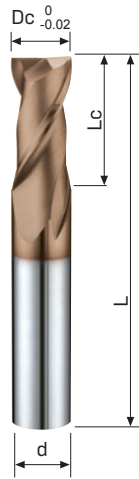

Code No. E162TX-Dc				
Dc 0 -0.02	Lc mm	L mm	d h6	AlTiSiN E162TX
0.1	0.3	50	4	●
0.2	0.5	50	4	●
0.3	0.8	50	4	●
0.4	1	50	4	●
0.5	1.2	50	4	●
0.6	1.5	50	4	●
0.8	2	50	4	●
1	3	50	4	●
1.5	5	50	4	●
2	6	50	4	●
2.5	8	50	4	●
3A	8	50	4	●
4A	11	50	4	●
3	8	50	6	●
3.5	10	50	6	●
4	11	50	6	●
4.5	11	50	6	●
5	13	50	6	●
5.5	13	50	6	●
6	16	50	6	●
7	20	60	8	●
8	20	60	8	●
9	22	72	10	●
10	22	72	10	●
11	26	75	12	●
12	26	75	12	●
14	32	90	16	●
16	38	100	16	●
18	38	100	20	●
20	38	100	20	●

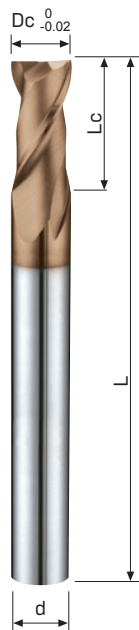

Code No. E163TX-Dc				
Dc 0 -0.02	Lc mm	L mm	d h6	AlTiSiN E163TX
3	12	70	6	●
4	15	70	6	●
5	20	80	6	●
6	20	80	6	●
7	25	100	8	●
8	25	100	8	●
9	30	100	10	●
10	30	100	10	●
11	35	110	12	●
12	40	110	12	●
14	40	120	16	●
16	50	140	16	●
20	60	160	20	●

Slotting

Work Material		GR.1 Carbon Steel		GR.2 Low-alloyed Steel (~24HRC)		GR.3 Hi-alloyed Steel (~30HRC)		GR.4 Hardened Steel (30~38HRC)		GR.5 Hardened Steel (38~48HRC)		GR.6 Hardened Steel (48~56HRC)	
Vc m/min		Ø0.1~0.7 28~57 Ø0.8~3.0 60~100 Ø3.1~20 109~120		Ø0.1~0.7 28~57 Ø0.8~3.0 60~100 Ø3.1~20 109~120		Ø0.1~0.7 20~50 Ø0.8~3.0 55~65 Ø3.1~20 65~80		Ø0.1~0.7 28~45 Ø0.8~3.0 48~80 Ø3.1~20 88~110		Ø0.1~0.7 28~34 Ø0.8~3.0 35~59 Ø3.1~20 65~70		Ø0.1~20 21~45	
Code No.	Dc	RPM (min-1)	Feed (mm/min)	RPM (min-1)	Feed (mm/min)	RPM (min-1)	Feed (mm/min)	RPM (min-1)	Feed (mm/min)	RPM (min-1)	Feed (mm/min)	RPM (min-1)	Feed (mm/min)
E162TX-0.1	0.1	30,000	100	30,000	100	30,000	100	30,000	100	30,000	50	30,000	25
E162TX-0.2	0.2	30,000	100	30,000	100	30,000	100	30,000	100	30,000	50	30,000	25
E162TX-0.3	0.3	30,000	110	30,000	110	30,000	110	30,000	110	30,000	55	22,000	25
E162TX-0.4	0.4	30,000	120	30,000	120	30,000	120	30,000	120	27,000	60	17,000	25
E162TX-0.5	0.5	30,000	120	30,000	120	29,000	120	29,000	120	21,500	60	13,000	25
E162TX-0.6	0.6	30,000	120	30,000	120	24,000	120	24,000	120	18,000	60	11,000	25
E162TX-0.8	0.8	24,000	120	24,000	120	19,000	120	19,000	120	13,800	60	8,800	30
E162TX-1	1	28,500	500	28,500	500	28,500	500	25,000	380	19,000	250	12,500	110
E162TX-1.5	1.5	22,000	505	22,000	505	22,000	505	19,250	390	14,500	255	9,650	115
E162TX-2	2	15,500	510	15,500	510	15,500	510	13,500	400	10,000	260	6,800	120
E162TX-2.5	2.5	13,000	530	13,000	530	13,000	530	11,000	405	8,150	270	5,800	130
E162TX/E163TX-3	3	10,500	550	10,500	550	10,500	550	8,500	410	6,300	280	4,800	140
E162TX-3.5	3.5	9,600	555	9,600	555	9,600	555	7,750	405	5,750	275	4,300	135
E162TX/E163TX-4	4	8,700	560	8,700	560	8,700	560	7,000	400	5,200	270	3,800	135
E162TX-4.5	4.5	7,700	550	7,700	550	7,700	550	6,500	450	4,800	260	3,500	130
E162TX/E163TX-5	5	7,500	545	7,500	545	7,500	545	6,150	475	4,450	250	3,225	125
E162TX-5.5	5.5	6,800	540	6,800	540	6,800	540	5,800	500	4,000	240	3,000	120
E162TX/E163TX-6	6	6,300	530	6,300	530	6,300	530	5,300	550	3,700	235	2,650	120
E162TX/E163TX-7	7	5,550	530	5,550	530	5,550	530	4,650	460	3,250	240	2,300	135
E162TX/E163TX-8	8	4,800	530	4,800	530	4,800	530	4,000	370	2,800	250	2,000	130
E162TX/E163TX-9	9	4,300	540	4,300	540	4,300	540	3,600	375	2,550	250	1,800	140
E162TX/E163TX-10	10	3,800	550	3,800	550	3,800	550	3,200	380	2,300	250	1,600	150
E162TX/E163TX-11	11	3,500	540	3,500	540	3,500	540	2,900	380	2,120	255	1,500	150
E162TX/E163TX-12	12	3,200	530	3,200	530	3,200	530	2,600	380	1,950	260	1,400	155
E162TX/E163TX-14	14	2,750	510	2,750	510	2,750	510	2,500	360	1,600	250	1,000	135
E162TX/E163TX-16	16	2,400	500	2,400	500	2,400	500	2,200	350	1,400	240	900	120
E162TX-18	18	2,200	480	2,200	480	2,200	480	1,950	320	1,200	220	800	110
E162TX/E163TX-20	20	1,900	460	1,900	460	1,900	460	1,750	300	1,100	200	720	110
(mm)		ap:<3 0.1D ≥3 0.2D		ap:<3 0.1D ≥3 0.2D		ap:<3 0.1D ≥3 0.2D		ap:<3 0.1D ≥3 0.2D		ap:<3 0.05D ≥3 0.1D		ap:<3 0.05D ≥3 0.1D	

※ Notice: E163TX is Long Length series End Mills. Please adjust the parameter according

1. Please work with good rigidity / high precision facilities and collet chuck.
2. Please choose proper cutting fluid.
3. The cutting data is reference value only. Please adjust it according to your real working conditions.
4. If RPM is lower the reference value, the Feed rate (fz) and RPM should be reduced by the same proportion.
5. If vibration occurs during cutting, please reduce cutting parameter.

E124X

Finishing End Mills

MG Carbide

AlTiN X-NaNo

35°

4

N

γ10°

90°

Type of Operation

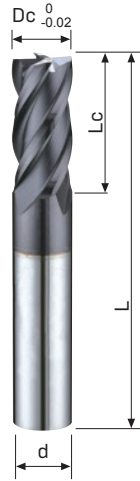

Code No. E124X-Dc

Dc 0 -0.02	Lc mm	L mm	d h6	AlTiN E124X
1	3	50	4	●
1.2	4	50	4	●
1.4	4	50	4	●
1.5	5	50	4	●
1.6	5	50	4	●
1.8	5	50	4	●
2	6	50	4	●
2.2	6	50	4	●
2.4	8	50	4	●
2.5	8	50	4	●
2.6	8	50	4	●
2.8	8	50	4	●
3A	8	50	4	●
4A	11	50	4	●
3	8	50	6	●
3.5	10	50	6	●
4	11	50	6	●
4.5	11	50	6	●
5	13	50	6	●
5.5	13	50	6	●
6	16	50	6	●
6.5	16	60	8	●
7	20	60	8	●
7.5	20	60	8	●
8	20	60	8	●
8.5	20	72	10	●
9	22	72	10	●
9.5	22	72	10	●
10	22	72	10	●
10.5	22	75	12	●
11	26	75	12	●
12	26	75	12	●
13	26	80	12	●
14	32	90	16	●
15	32	90	16	●
16	38	100	16	●
17	38	100	20	●
18	38	100	20	●
19	38	100	20	●
20	38	100	20	●

Work Material

P	H	M	K	N	S
●	●	○	●	○	○

P	Steel
---	-------

H	<38HRC Hardened Steel
---	--------------------------

H	<48HRC Hardened Steel
---	--------------------------

M	Stainless Steel
---	-----------------

K	Cast Iron
---	-----------

N	Copper
---	--------

Feature of product:

Finishing End Mills- 4 Flutes
Nano multilayer coating enable to enhance wear resistance.

Suitable for general and finishing process with excellent cutting surface on work piece.

Code No. E124X-Dc

Dc 0 -0.02	Lc mm	L mm	d h6	AlTiN E124X	
1/8	3.175	8	50	6	●
3/16	4.760	12	50	6	●
1/4	6.350	18	60	8	●
5/16	7.940	20	60	8	●
3/8	9.525	22	72	10	●
1/2	12.700	26	75	12	●
5/8	15.880	38	100	16	●
3/4	19.050	38	100	20	●

Side Milling

Work Material		GR.1 Carbon Steel		GR.2 Low-alloyed Steel (~24HRC)		GR.3 Hi-alloyed Steel (~30HRC)		GR.4 Hardened Steel (30~38HRC)		GR.5 Hardened Steel (38~48HRC)		GR.8 Stainless Steel		GR.9 Cast Iron		GR.11 Copper	
Vc m/min		85		85		75		60		50		60		85		150	
Code No.	Dc	RPM (min-1)	Feed (mm/min)	RPM (min-1)	Feed (mm/min)	RPM (min-1)	Feed (mm/min)	RPM (min-1)	Feed (mm/min)	RPM (min-1)	Feed (mm/min)	RPM (min-1)	Feed (mm/min)	RPM (min-1)	Feed (mm/min)	RPM (min-1)	Feed (mm/min)
E124X-1	1	20,000	240	20,000	240	15,000	210	11,000	85	7,100	40	11,000	85	20,000	240	47,600	420
E124X-1.5	1.5	13,500	250	13,500	250	12,500	215	8,000	90	6,900	80	8,000	90	13,500	250	31,800	620
E124X-2	2	13,000	300	13,000	300	11,000	280	7,000	110	6,350	100	7,000	110	13,000	300	24,000	590
E124X-2.5	2.5	11,000	370	11,000	370	9,500	245	6,300	110	5,500	105	6,300	110	11,000	370	19,200	960
E124X-3	3	9,000	480	9,000	480	7,400	350	5,300	120	4,800	110	5,300	120	9,000	480	15,800	860
E124X-3.5	3.5	7,800	490	7,800	490	6,500	350	4,800	130	4,300	110	4,800	130	7,800	490	13,600	860
E124X-4	4	6,650	500	6,650	500	5,500	350	4,250	135	3,700	115	4,250	135	6,650	500	12,000	900
E124X-4.5	4.5	6,000	550	6,000	550	5,000	385	3,870	130	3,450	120	3,870	130	5,950		10,700	970
E124X-5	5	5,300	600	5,300	600	4,500	420	3,500	130	3,200	120	3,500	130	5,300	600	9,400	1,040
E124X-5.5	5.5	4,900	600	4,900	600	4,100	420	3,250	135	2,920	125	3,250	135	4,900		8,600	1,040
E124X-6	6	4,500	600	4,500	600	3,700	425	3,000	140	2,650	125	3,000	140	4,500	600	7,800	1,040
E124X-7	7	3,900	575	3,900	575	2,950	410	2,420	130	2,250	125	2,420	130	3,900		6,800	1,025
E124X-8	8	3,300	550	3,300	550	2,600	410	1,850	120	1,900	125	1,850	120	3,300	550	5,800	1,010
E124X-9	9	2,950	535	2,950	535	2,350	405	1,650	125	1,700	130	1,650	125	2,950		5,300	1,010
E124X-10	10	2,600	520	2,600	520	2,100	400	1,500	125	1,500	130	1,500	125	2,600	520	4,800	1,010
E124X-11	11	2,400	520	2,400	520	1,950	405	1,350	125	1,350	120	1,350	120	2,400		4,400	1,010
E124X-12	12	2,200	520	2,200	520	1,800	405	1,200	120	1,200	120	1,200	120	2,200	520	4,000	1,010
E124X-13	13	2,050	535	2,050	535	1,700	410	1,200	130	1,150	120	1,200	130	2,050		3,700	1,000
E124X-14	14	1,900	550	1,900	550	1,600	410	1,200	140	1,100	120	1,200	140	1,900	550	3,400	990
E124X-15	15	1,800	540	1,800	540	1,500	410	1,150	130	1,050	100	1,050	135	1,800		3,200	975
E124X-16	16	1,700	530	1,700	530	1,400	410	1,100	130	1,000	100	1,100	130	1,700	530	3,000	960
E124X-17	17	1,600	525	1,600	525	1,300	405	1,020	100	940	95	1,020	115	1,600		2,800	950
E124X-18	18	1,500	520	1,500	520	1,200	405	950	100	880	95	950	100	1,500	520	2,600	940
E124X-19	19	1,400	510	1,400	510	1,150	385	925	90	840	90	925	95	1,400		2,500	910
E124X-20	20	1,300	500	1,300	500	1,100	370	900	90	800	90	900	90	1,300	500	2,400	890
(mm)		ap:1.5D		ap:1.5D		ap:1.5D		ap:1.5D		ap:1.5D		ap:1.5D		ap:1.5D		ap:1.5D	
		ae:<3 0.05D ≥3 0.1D		ae:<3 0.05D ≥3 0.1D		ae:<3 0.05D ≥3 0.1D		ae:<3 0.05D ≥3 0.1D		ae:<3 0.01D ≥3 0.02D		ae:<3 0.05D ≥3 0.1D		ae:<3 0.05D ≥3 0.1D		ae:<3 0.05D ≥3 0.1D	

1. Please work with good rigidity / high precision facilities and collet chuck.
2. Please choose proper cutting fluid.
3. The cutting data is reference value only. Please adjust it according to your real working conditions.
4. If RPM is lower the reference value, the Feed rate [fz] and RPM should be reduced by the same proportion.
5. If vibration occurs during cutting, please reduce cutting parameter.

E126X / E128X

Finishing End Mills

MG
CarbideAlTiN
X-NaNo

Type of Operation



Work Material

P	H	M	K	N	S
●	●	○	●	○	○

P	Steel
---	-------

H	<38HRC Hardened Steel
---	--------------------------

H	<48HRC Hardened Steel
---	--------------------------

M	Stainless Steel
---	-----------------

K	Cast Iron
---	-----------

N	Copper
---	--------

Feature of product:

Finishing End Mills with Long Length- 4 Flutes

Nano multilayer coating enable to enhance wear resistance.

Suitable for finishing and general cutting process, extended length enable to work on deeper work piece with excellent cutting surface.

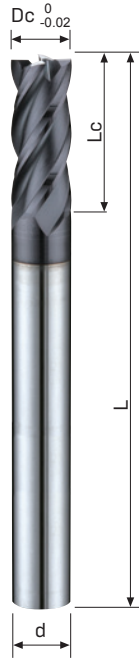

Dc	Lc	L	d	AITiN
0 -0.02	mm	mm	h6	E126X
3	12	70	6	●
4	15	70	6	●
5	20	80	6	●
6	20	80	6	●
7	25	100	8	●
8	25	100	8	●
9	30	100	10	●
10	30	100	10	●
11	35	110	12	●
12	40	110	12	●
14	40	120	16	●
16	50	140	16	●
20	60	160	20	●

Code No. E126X-Dc

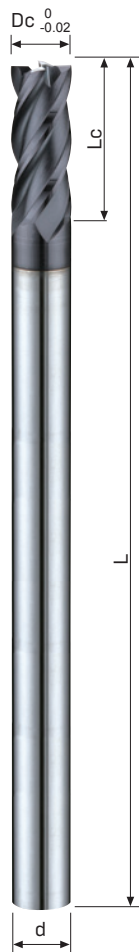

Dc	Lc	L	d	AITiN
0 -0.02	mm	mm	h6	E128X
3	12	80	4	●
4	15	80	4	●
5	20	100	6	●
6	20	100	6	●
8	25	130	8	●
10	30	160	10	●
12	40	180	12	●
16	50	210	16	●
20	60	210	20	●

Code No. E128X-Dc

Side Milling

Work Material		GR.1 Carbon Steel		GR.2 Low-alloyed Steel (~24HRC)		GR.3 Hi-alloyed Steel (~30HRC)		GR.4 Hardened Steel (30~38HRC)		GR.5 Hardened Steel (38~48HRC)		GR.8 Stainless Steel		GR.9 Cast Iron		GR.11 Copper	
Vc m/min		65		65		55		40		38		40		65		115	
Code No.	Dc	RPM (min-1)	Feed (mm/min)	RPM (min-1)	Feed (mm/min)	RPM (min-1)	Feed (mm/min)	RPM (min-1)	Feed (mm/min)	RPM (min-1)	Feed (mm/min)	RPM (min-1)	Feed (mm/min)	RPM (min-1)	Feed (mm/min)	RPM (min-1)	Feed (mm/min)
E126X/E128X-3	3	6,750	360	6,750	360	5,550	265	3,975	90	3,600	85	3,975	90	6,750	360	11,850	645
E126X/E128X-4	4	5,000	375	5,000	375	4,125	265	3,200	100	2,775	85	3,200	100	5,000	375	9,000	675
E126X/E128X-5	5	3,975	450	3,975	450	3,375	315	2,625	100	2,400	90	2,625	100	3,975	450	7,050	780
E126X/E128X-6	6	3,375	450	3,375	450	2,775	320	2,250	105	1,988	95	2,250	105	3,375	450	5,850	780
E126X-7	7	2,900	430	2,900	430	2,360	315	1,800	100	1,700	95	1,820	100	2,900	430	5,000	770
E126X/E128X-8	8	2,475	410	2,475	410	1,950	310	1,400	90	1,425	95	1,400	90	2,475	410	4,350	760
E126X-9	9	2,200	400	2,200	400	1,775	305	1,270	95	1,270	100	1,250	95	2,200	400	3,950	760
E126X/E128X-10	10	1,950	390	1,950	390	1,575	300	1,125	95	1,125	100	1,125	95	1,950	390	3,600	760
E126X-11	11	1,800	390	1,800	390	1,450	305	1,000	90	1,000	95	1,000	90	1,800	390	3,300	760
E126X/E128X-12	12	1,650	390	1,650	390	1,350	305	900	90	900	90	900	90	1,650	390	3,000	760
E126X-14	14	1,430	413	1,430	413	1,200	310	900	105	825	90	900	105	1,430	413	2,550	750
E126X/E128X-16	16	1,275	400	1,275	400	1,050	310	825	100	750	75	825	100	1,275	400	2,250	720
E126X/E128X-20	20	975	375	975	375	825	275	675	70	600	70	675	70	975	375	1,800	670
(mm)		ap:2.5D		ap:2.5D		ap:2.5D		ap:2.5D		ap:2.5D		ap:2.5D		ap:2.5D		ap:2.5D	
		ae:0.1D		ae:0.1D		ae:0.1D		ae:0.1D		ae:0.1D		ae:0.1D		ae:0.1D		ae:0.1D	

※ Notice: E128X is Long Length series End Mills. Please adjust the parameter according

1. Please work with good rigidity / high precision facilities and collet chuck.
2. Please choose proper cutting fluid.
3. The cutting data is reference value only. Please adjust it according to your real working conditions.
4. If RPM is lower the reference value, the Feed rate [fz] and RPM should be reduced by the same proportion.
5. If vibration occurs during cutting, please reduce cutting parameter.

E164TX / E165TX

Finishing End Mills

UMG
Carbide

AlTiSiN
TX



Type of Operation

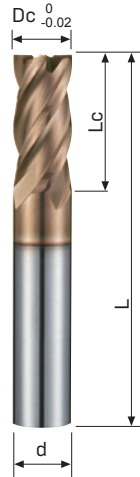

Code No. E164TX-Dc

Dc	Lc	L	d	AlTiSiN
$0_{-0.02}$	mm	mm	h6	E164TX
1	3	50	4	●
1.5	5	50	4	●
2	6	50	4	●
2.5	8	50	4	●
3A	8	50	4	●
4A	11	50	4	●
3	8	50	6	●
3.5	10	50	6	●
4	11	50	6	●
4.5	11	50	6	●
5	13	50	6	●
5.5	13	50	6	●
6	16	50	6	●
7	20	60	8	●
8	20	60	8	●
9	22	72	10	●
10	22	72	10	●
11	26	75	12	●
12	26	75	12	●
14	32	90	16	●
16	38	100	16	●
18	38	100	20	●
20	38	100	20	●

Work Material

P	H	M	K	N	S
●	●				

P	Steel
---	-------

H	<38HRC Hardened Steel
---	--------------------------

H	<48HRC Hardened Steel
---	--------------------------

H	<56HRC Hardened Steel
---	--------------------------

H	<68HRC Hardened Steel
---	--------------------------

Feature of product:

Finishing End Mills with Standard & Long Length- 4 Flutes

Using UMG carbide material and coated with high wear resistance TX coating enable to enhance tool life.

The small rake angle design with strong cutting edge for chipping resistance, suitable for high hardness material finishing process.

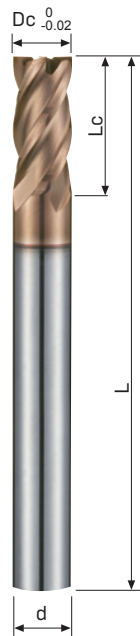

Code No. E165TX-Dc

Dc	Lc	L	d	AlTiSiN
$0_{-0.02}$	mm	mm	h6	E165TX
3	12	70	6	●
4	15	70	6	●
5	20	80	6	●
6	20	80	6	●
7	25	100	8	●
8	25	100	8	●
9	30	100	10	●
10	30	100	10	●
11	35	110	12	●
12	40	110	12	●
14	40	120	16	●
16	50	140	16	●
20	60	160	20	●

Side Milling

Work Material		GR.1 Carbon Steel		GR.2 Low-alloyed Steel (~24HRC)		GR.3 Hi-alloyed Steel (~30HRC)		GR.4 Hardened Steel (30~38HRC)		GR.5 Hardened Steel (38~48HRC)		GR.6 Hardened Steel (48~56HRC)		GR.7 Hardened Steel (56~68HRC)	
Vc m/min		Ø1.0~2.5 63~70 Ø3.0~20 108~122		Ø1.0~2.5 63~70 Ø3.0~20 108~122		Ø1.0~2.5 63~70 Ø3.0~20 108~122		Ø1.0~2.0 63~67 Ø3.0~20 69~72		Ø1.0~2.0 63~67 Ø3.0~20 69~72		Ø1.0~20 30~45		Ø1.0~20 30~40	
Code No.	Dc	RPM (min-1)	Feed (mm/min)	RPM (min-1)	Feed (mm/min)	RPM (min-1)	Feed (mm/min)	RPM (min-1)	Feed (mm/min)	RPM (min-1)	Feed (mm/min)	RPM (min-1)	Feed (mm/min)	RPM (min-1)	Feed (mm/min)
E164TX-1	1	20,000	240	20,000	240	20,000	240	20,000	185	20,000	185	10,000	60	9,500	40
E164TX-1.5	1.5	15,000	245	15,000	245	15,000	245	15,000	185	15,000	185	7,100	70	6,300	50
E164TX-2	2	11,000	480	11,000	480	11,000	480	10,000	300	10,000	300	6,400	150	4,800	95
E164TX-2.5	2.5	8,800	600	8,800	600	8,800	600	8,500	350	8,500	350	5,600	170	4,500	100
E164TX/E165TX-3	3	11,500	500	11,500	500	11,500	500	7,300	450	7,300	450	4,800	220	4,000	150
E164TX-3.5	3.5	10,000	510	10,000	510	10,000	510	6,400	475	6,400	475	4,200	235	3,600	185
E164TX/E165TX-4	4	8,600	515	8,600	515	8,600	515	5,600	500	5,600	500	3,600	250	3,200	220
E164TX-4.5	4.5	7,700	515	7,700	515	7,700	515	5,100	525	5,100	525	3,250	265	2,900	220
E164TX/E165TX-5	5	6,800	515	6,800	515	6,800	515	4,500	550	4,500	550	2,900	280	2,600	220
E164TX-5.5	5.5	6,300	515	6,300	515	6,300	515	4,100	575	4,100	575	2,650	290	2,350	220
E164TX/E165TX-6	6	5,800	520	5,800	520	5,800	520	3,700	600	3,700	600	2,400	300	2,100	220
E164TX-7	7	5,050	520	5,050	520	5,050	520	3,250	610	3,250	610	2,100	305	1,850	210
E164TX/E165TX-8	8	4,300	520	4,300	520	4,300	520	2,800	620	2,800	620	1,800	310	1,600	210
E164TX-9	9	3,850	530	3,850	530	3,850	530	2,550	620	2,550	620	1,600	305	1,450	195
E164TX/E165TX-10	10	3,400	540	3,400	540	3,400	540	2,300	620	2,300	620	1,400	300	1,300	180
E164TX-11	11	3,150	545	3,150	545	3,150	545	2,100	620	2,100	620	1,300	300	1,200	165
E164TX/E165TX-12	12	2,900	545	2,900	545	2,900	545	1,900	620	1,900	620	1,200	300	1,100	150
E164TX-14	14	2,650	575	2,650	575	2,650	575	1,650	550	1,650	550	1,050	265	950	125
E164TX/E165TX-16	16	2,400	610	2,400	610	2,400	610	1,400	480	1,400	480	900	230	800	120
E164TX-18	18	2,250	620	2,250	620	2,250	620	1,250	450	1,250	450	810	220	720	105
E164TX/E165TX-20	20	1,950	630	1,950	630	1,950	630	1,100	420	1,100	420	720	210	640	90
(mm)		ap:1.5D		ap:1.5D		ap:1.5D		ap:1.5D		ap:1.5D		ap:1.5D		ap:1.5D	
		ae:<3 0.02D ≥3 0.05D		ae:<3 0.02D ≥3 0.05D		ae:<3 0.02D ≥3 0.05D		ae:<3 0.02D ≥3 0.05D		ae:<3 0.02D ≥3 0.05D		ae:0.02D		ae:0.02D	

※ Notice: E165TX is Long Length series End Mills. Please adjust the parameter according

1. Please work with good rigidity / high precision facilities and collet chuck.
2. Please choose proper cutting fluid.
3. The cutting data is reference value only. Please adjust it according to your real working conditions.
4. If RPM is lower the reference value, the Feed rate (fz) and RPM should be reduced by the same proportion.
5. If vibration occurs during cutting, please reduce cutting parameter.

E158TX / E159TX

High Performance End Mills

SMG
CarbideAlTiSiN
TX

Type of Operation

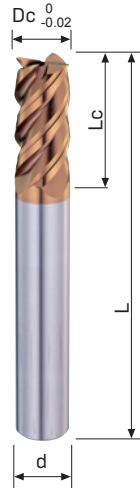

Code No. E158TX-Dc				
Dc 0 -0.02	Lc mm	L mm	d h6	AlTiSiN E158TX
1	3	50	4	●
1.5	5	50	4	●
2	6	50	4	●
2.5	8	50	4	●
3A	8	50	4	●
4A	11	50	4	●
3	8	50	6	●
4	11	50	6	●
5	13	50	6	●
6	16	50	6	●
8	20	60	8	●
10	22	72	10	●
12	26	75	12	●
16	38	100	16	●
20	38	100	20	●

Work Material

P	H	M	K	N	S
●	●	●	●	○	○

P Steel

H <38HRC
Hardened SteelH <48HRC
Hardened SteelH <56HRC
Hardened SteelH <68HRC
Hardened Steel

M Stainless Steel

K Cast Iron

N Aluminium

N Copper

S Titanium

S Nickel

S High Temp Alloys



Code No. E159TX-Dc				
Dc 0 -0.02	Lc mm	L mm	d h6	AlTiSiN E159TX
3	12	70	6	●
4	15	70	6	●
5	20	80	6	●
6	20	80	6	●
8	25	100	8	●
10	30	100	10	●
12	40	110	12	●
16	50	140	16	●
20	60	160	20	●

Feature of product:

Finishing End Mills with Standard & Long Length- 4 Flutes

Negative rake angle design makes cutting edge strong and chipping resistance.

High efficiency 45° helix angle enable to reduce cutting resistance.

Suitable for high hardness material finishing process.

Side Milling

Work Material		GR.1 Carbon Steel		GR.2 Low-alloyed Steel (~24HRC)		GR.3 Hi-alloyed Steel (~30HRC)		GR.4 Hardened Steel (30-38HRC)		GR.5 Hardened Steel (38-48HRC)		GR.5 Hardened Steel (48-56HRC)		GR.5 Hardened Steel (56-68HRC)		GR.8 Stainless Steel		GR.9 Cast Iron	
Vc m/min		100		100		80		65		62		60		30		62		100	
Code No.	Dc	RPM (min-1)	Feed (mm/min)	RPM (min-1)	Feed (mm/min)	RPM (min-1)	Feed (mm/min)	RPM (min-1)	Feed (mm/min)	RPM (min-1)	Feed (mm/min)	RPM (min-1)	Feed (mm/min)	RPM (min-1)	Feed (mm/min)	RPM (min-1)	Feed (mm/min)	RPM (min-1)	Feed (mm/min)
E158TX-1	1	31,850	509	31,850	509	25,480	407	20,700	331	19,747	315	19,110	305	9,555	152	19,747	315	31,850	509
E158TX-1.5	1.5	21,233	594	21,233	594	16,986	475	13,800	386	13,164	368	12,740	305	6,370	152	13,164	368	21,233	594
E158TX-2	2	15,925	637	15,925	637	12,740	560	10,351	455	9,873	395	9,555	344	4,777	152	9,873	395	15,925	637
E158TX-2.5	2.5	12,740	764	12,740	764	10,192	611	8,281	496	7,898	473	7,644	458	3,822	152	7,898	473	12,740	764
E158TX-3	3	10,600	950	10,600	950	8,300	750	7,000	560	6,600	510	6,400	480	3,200	180	6,600	510	10,600	950
E158TX-4	4	8,000	1,000	8,000	1,000	6,150	800	5,200	560	5,000	600	4,800	510	2,400	185	5,000	600	8,000	1,000
E158TX-5	5	6,350	1,000	6,350	1,000	5,000	840	4,200	580	4,000	610	3,800	530	2,000	190	4,000	610	6,350	1,000
E158TX/E159TX-6	6	5,300	1,200	5,300	1,200	4,200	950	3,500	700	3,300	650	3,200	540	1,600	190	3,300	650	5,300	1,200
E158TX/E159TX-8	8	4,000	1,200	4,000	1,200	3,100	900	2,700	650	2,500	640	2,400	550	1,200	175	2,500	640	4,000	1,200
E158TX/E159TX-10	10	3,200	1,100	3,200	1,100	2,500	850	2,100	600	2,000	585	1,900	520	950	155	2,000	585	3,200	1,100
E158TX/E159TX-12	12	2,650	1,100	2,650	1,100	2,000	850	1,750	560	1,700	530	1,600	470	800	160	1,700	530	2,650	1,100
E158TX/E159TX-16	16	2,000	950	2,000	950	1,600	730	1,300	500	1,250	430	1,200	400	600	160	1,250	430	2,000	950
E158TX/E159TX-20	20	1,600	760	1,600	760	1,300	580	1,100	450	980	380	950	350	480	160	980	380	1,600	760
(mm)		ap:1.5D		ap:1.5D		ap:1.5D		ap:1.5D		ap:1.5D		ap:1.0D		ap:1.0D		ap:1.5D		ap:1.5D	
		ae:0.2D		ae:0.2D		ae:0.2D		ae:0.1D		ae:0.1D		ae:0.05D		ae:0.05D		ae:0.1D		ae:0.2D	

※ Notice: E159TX is Long Length series End Mills. Please adjust the parameter according

Side Milling (High-speed machining)

Work Material		GR.1 Carbon Steel		GR.2 Low-alloyed Steel (~24HRC)		GR.3 Hi-alloyed Steel (~30HRC)		GR.4 Hardened Steel (30-38HRC)		GR.5 Hardened Steel (38-48HRC)		GR.5 Hardened Steel (48-56HRC)		GR.5 Hardened Steel (56-68HRC)		GR.8 Stainless Steel		GR.9 Cast Iron	
Vc m/min		200		200		200		200		150		100		80		150		200	
Code No.	Dc	RPM (min-1)	Feed (mm/min)	RPM (min-1)	Feed (mm/min)	RPM (min-1)	Feed (mm/min)	RPM (min-1)	Feed (mm/min)	RPM (min-1)	Feed (mm/min)	RPM (min-1)	Feed (mm/min)	RPM (min-1)	Feed (mm/min)	RPM (min-1)	Feed (mm/min)	RPM (min-1)	Feed (mm/min)
E158TX-3	3	21,233	1,274	21,233	1,274	21,233	1,274	21,233	1,274	15,925	955	10,616	637	8493	509	15,925	955	21,233	1,274
E158TX-4	4	15,925	1,274	15,925	1,274	15,925	1,274	15,925	1,274	11,943	955	7,962	637	6370	509	11,943	955	15,925	1,274
E158TX-5	5	12,740	1,528	12,740	1,528	12,740	1,528	12,740	1,528	9,555	1,146	6,370	764	5096	509	9,555	1,146	12,740	1,528
E158TX-6	6	10,500	2,800	10,500	2,800	10,500	2,500	10,500	1,800	8,000	1,350	5,300	900	4,200	600	8,000	1,350	10,500	2,800
E158TX-8	8	8,000	2,400	8,000	2,400	8,000	2,300	8,000	1,700	5,900	1,350	4,000	850	3,200	550	5,900	1,350	8,000	2,400
E158TX-10	10	6,300	2,350	6,300	2,350	6,300	2,200	6,300	1,650	4,700	1,300	3,200	800	2,500	500	4,700	1,300	6,300	2,350
E158TX-12	12	5,300	2,350	5,300	2,350	5,300	2,100	5,300	1,650	4,000	1,300	2,600	785	2,100	480	4,000	1,300	5,300	2,350
E158TX-16	16	4,000	1,800	4,000	1,800	4,000	1,800	4,000	1,600	3,000	1,200	2,000	780	1,600	480	3,000	1,200	4,000	1,800
E158TX-20	20	3,200	1,500	3,200	1,500	3,200	1,500	3,200	1,450	2,400	1,100	1,600	730	1,300	475	2,400	1,100	3,200	1,500
(mm)		ap:1.5D		ap:1.5D		ap:1.5D		ap:1.5D		ap:1.5D		ap:1.0D		ap:1.0D		ap:1.5D		ap:1.5D	
		ae:0.05D		ae:0.02D		ae:0.05D		ae:0.05D		ae:0.05D		ae:0.02D		ae:0.02D		ae:0.05D		ae:0.05D	

1. Please work with good rigidity / high precision facilities and collet chuck.
2. Please choose proper cutting fluid.
3. The cutting data is reference value only. Please adjust it according to your real working conditions.
4. If RPM is lower the reference value, the Feed rate (fz) and RPM should be reduced by the same proportion.
5. If vibration occurs during cutting, please reduce cutting parameter.

E168TX / E169TX

High Performance End Mills

SMG Carbide

AlTiSiN TX

55°

4

N

$\gamma-10^\circ$

0.05-0.15

45°

Type of Operation

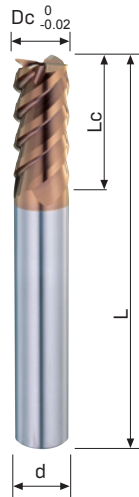

Code No. E168TX-Dc

Dc 0 -0.02	Lc mm	L mm	d h6	AlTiSiN E168TX
3	8	50	6	●
4	11	50	6	●
5	13	50	6	●
6	16	50	6	●
8	20	60	8	●
10	22	72	10	●
12	26	75	12	●
16	38	100	16	●
20	38	100	20	●

Work Material

P	H	M	K	N	S
	●				

H	<48HRC Hardened Steel
---	--------------------------

H	<56HRC Hardened Steel
---	--------------------------

H	<68HRC Hardened Steel
---	--------------------------

Feature of product:

Finishing End Mills with Standard & Long Length- 4 Flutes

Using SMG carbide material and coated with high wear resistance TX coating enable to enhance tool life.

Negative rake angle design makes cutting edge strong and chipping resistance.

High efficiency 55° helix angle enable to reduce cutting resistance.

Suitable for high hardness material finishing process.



Code No. E169TX-Dc

Dc 0 -0.02	Lc mm	L mm	d h6	AlTiSiN E169TX
6	20	80	6	●
8	25	100	8	●
10	30	100	10	●
12	40	110	12	●
16	50	140	16	●
20	60	160	20	●

Side Milling

Work Material		GR.5 Hardened Steel (38-48HRC)		GR.6 Hardened Steel (48-56HRC)		GR.7 Hardened Steel (56-68HRC)	
Vc m/min		150		100		50	
Code No.	Dc	RPM (min ⁻¹)	Feed (mm/min)	RPM (min ⁻¹)	Feed (mm/min)	RPM (min ⁻¹)	Feed (mm/min)
E168TX-3	3	15,800	1,200	10,500	820	3,800	120
E168TX-4	4	12,000	1,300	8,000	800	2,650	135
E168TX-5	5	9,500	1,300	6,300	850	2,250	140
E168TX/E169TX-6	6	8,000	1,200	5,300	820	2,200	175
E168TX/E169TX-8	8	6,000	1,100	4,000	750	1,650	185
E168TX/E169TX-10	10	4,800	1,100	3,200	745	1,300	165
E168TX/E169TX-12	12	4,000	1,065	2,700	740	1,100	145
E168TX/E169TX-16	16	3,000	1,000	2,000	730	840	170
E168TX/E169TX-20	20	2,400	955	1,600	700	670	170
(mm) 		ap:1.5D		ap:1.5D		ap:1.5D	
		ae:0.05D		ae:0.03D		ae:0.02D	

High Speed Side Milling

Work Material		GR.5 Hardened Steel (38-48HRC)		GR.6 Hardened Steel (48-56HRC)		GR.7 Hardened Steel (56-68HRC)	
Vc m/min		200		150		100	
Code No.	Dc	RPM (min ⁻¹)	Feed (mm/min)	RPM (min ⁻¹)	Feed (mm/min)	RPM (min ⁻¹)	Feed (mm/min)
E168TX-3	3	21,233	1,620	15,925	1,130	10,617	424
E168TX-4	4	15,925	1,725	11,944	1,200	7,963	477
E168TX-5	5	12,740	1,750	9,555	1,200	6,370	510
E168TX-6	6	10,617	1,200	7,963	700	5,308	530
E168TX-8	8	7,963	1,200	5,972	700	3,981	530
E168TX-10	10	6,370	850	4,778	630	3,185	420
E168TX-12	12	5,308	850	3,981	630	2,654	420
E168TX-16	16	3,981	900	2,986	650	1,991	420
E168TX-20	20	3,185	900	2,389	650	1,593	420
(mm) 		ap:1.5D		ap:1.5D		ap:1.5D	
		ae:0.01D		ae:0.01D		ae:0.01D	

※ Notice: E169TX is Long Length series End Mills. Please adjust the parameter according

1. Please work with good rigidity / high precision facilities and collet chuck.
2. Please choose proper cutting fluid.
3. The cutting data is reference value only. Please adjust it according to your real working conditions.
4. If RPM is lower the reference value, the Feed rate (fz) and RPM should be reduced by the same proportion.
5. If vibration occurs during cutting, please reduce cutting parameter.

E166TX / E167TX

Finishing End Mills

SMG
CarbideAlTiSiN
TX

Type of Operation

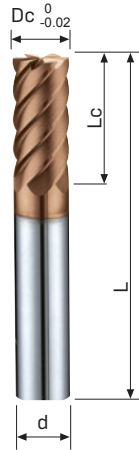

Code No. E166TX-Dc

Dc 0 -0.02	Lc mm	L mm	d h6	NO.of Flute	AlTiSiN E166TX
3	8	50	6	4	●
4	11	50	6	4	●
5	13	50	6	6	●
6	16	50	6	6	●
8	20	60	8	6	●
10	22	72	10	6	●
12	26	75	12	6	●
16	38	100	16	6	●
20	38	100	20	6	●

Work Material

P	H	M	K	N	S
	●		○		○

H <48HRC
Hardened SteelH <56HRC
Hardened SteelH <68HRC
Hardened Steel

K Cast Iron

S Titanium

S High Temp Alloys

Feature of product:

Finishing End Mills with Standard & Long Length- 6 Flutes

Using SMG carbide material and coated with high wear resistance TX coating enable to enhance tool life.

Negative rake angle design makes cutting edge strong and chipping resistance.

Multi flutes design enable to decrease cutting edge pressure evenly, increase core strength and tool life.

High efficiency 45° helix angle enable to reduce cutting resistance.

Suitable for high hardness material in finishing process.

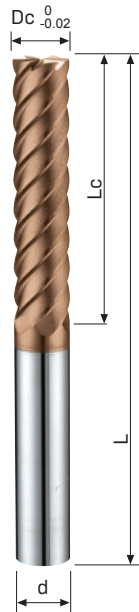

Code No. E167TX-Dc

Dc 0 -0.02	Lc mm	L mm	d h6	NO.of Flute	AlTiSiN E167TX
6	26	80	6	6	●
8	36	100	8	6	●
10	46	100	10	6	●
12	56	110	12	6	●
16	66	140	16	6	●
20	76	160	20	6	●

E166TX Side Milling

Work Material		GR.5 Hardened Steel (38-48HRC)		GR.6 Hardened Steel (48-56HRC)		GR.7 Hardened Steel (56-68HRC)		GR.9 Cast Iron	
Vc m/min		150		100		90		145	
Code No.	Dc	RPM (min-1)	Feed (mm/min)	RPM (min-1)	Feed (mm/min)	RPM (min-1)	Feed (mm/min)	RPM (min-1)	Feed (mm/min)
E166TX-3	3	13,500	1,600	10,500	1,200	7,900	650	15,000	1,800
E166TX-4	4	9,900	1,600	7,900	1,200	5,900	660	11,000	1,800
E166TX-5	5	7,900	1,580	6,300	1,200	4,700	650	8,800	1,750
E166TX-6	6	6,600	2,300	5,300	1,800	4,000	1,000	7,400	2,600
E166TX-8	8	4,900	2,350	4,000	1,850	3,000	1,000	5,500	2,600
E166TX-10	10	4,000	2,400	3,200	1,900	2,400	1,000	4,500	2,600
E166TX-12	12	3,300	2,400	2,600	1,900	2,000	1,000	3,700	2,600
E166TX-16	16	2,500	2,100	2,000	1,700	1,500	900	2,800	2,400
E166TX-20	20	2,000	1,900	1,600	1,400	1,200	830	2,300	2,100
(mm) 		ap:1.5D		ap:1.5D		ap:1.5D		ap:1.6D	
		ae:0.1D		ae:0.05D		ae:0.03D		ae:0.1D	



















E167TX Side Milling

Work Material		GR.5 Hardened Steel (38-48HRC)		GR.6 Hardened Steel (48-56HRC)		GR.7 Hardened Steel (56-68HRC)		GR.9 Cast Iron	
Vc m/min		45		35		30		70	
Code No.	Dc	RPM (min-1)	Feed (mm/min)	RPM (min-1)	Feed (mm/min)	RPM (min-1)	Feed (mm/min)	RPM (min-1)	Feed (mm/min)
E167TX-6	6	2,100	530	1,500	300	1,350	230	3,200	850
E167TX-8	8	1,800	550	1,200	310	1,100	250	2,800	1,000
E167TX-10	10	1,600	550	1,150	340	1,000	260	2,400	1,000
E167TX-12	12	1,300	520	1,000	280	800	230	1,950	970
E167TX-16	16	985	450	700	230	600	200	1,400	800
E167TX-20	20	800	380	570	210	480	160	1,100	660
(mm) 		ap:3.0D		ap:3.0D		ap:3.0D		ap:3.0D	
		ae:0.1D		ae:0.05D		ae:0.05D		ae:0.1D	

1. Please work with good rigidity / high precision facilities and collet chuck.
2. Please choose proper cutting fluid.
3. The cutting data is reference value only. Please adjust it according to your real working conditions.
4. If RPM is lower the reference value, the Feed rate (fz) and RPM should be reduced by the same proportion.
5. If vibration occurs during cutting, please reduce cutting parameter.

Ball Nose End Mills



Page	111	113	115	117	117	119
Appearance						
Code No	B222X	B232X B242X B246X	B262TX B263TX B264TX	B272ATX	B273ATX	B251TX
Carbide	MG Carbide	MG Carbide	SMG Carbide	SMG Carbide	SMG Carbide	SMG Carbide
Coating	AlTiN X-NaNo	AlTiN X-NaNo	AlTiSiN TX	AlTiSiN ATX	AlTiSiN ATX	AlTiSiN TX
Helix Angle	 30°	 30°	 30°	 30°	 30°	 25°
No. of Flutes	 2	 2	 2	 2	 2	 2

ASIA

121 123 123 125



B261TX B253TX B254TX B250TX

SMG Carbide SMG Carbide SMG Carbide UMG Carbide

AlTiSiN TX AlTiSiN TX AlTiSiN TX AlTiSiN TX

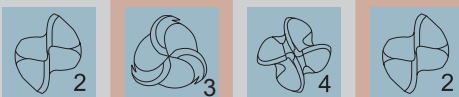

B222X

Ball Nose End Mills

MG
Carbide

AlTiN
X-NaNo



Type of Operation

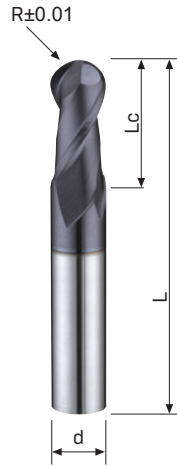

Code No. B222X-Dc

Dc	R	Lc	L	d	AlTiN B222X
0 -0.02	±0.01	mm	mm	h6	
0.1	0.05R	0.2	50	4	●
0.2	0.1R	0.4	50	4	●
0.3	0.15R	0.6	50	4	●
0.4	0.2R	0.8	50	4	●
0.5	0.25R	1	50	4	●
0.6	0.3R	1.2	50	4	●
0.7	0.35R	1.4	50	4	●
0.8	0.4R	1.6	50	4	●
0.9	0.45R	1.8	50	4	●
1	0.5R	2	50	4	●
1.2	0.6R	2.4	50	4	●
1.4	0.7R	2.8	50	4	●
1.5	0.75R	3	50	4	●
1.6	0.8R	3.2	50	4	●
1.8	0.9R	3.6	50	4	●
2	1R	4	50	4	●
2.5	1.25R	5	50	4	●
3A	1.5R	6	50	4	●
4A	2R	8	50	4	●
3	1.5R	6	50	6	●
3.5	1.75R	8	50	6	●
4	2R	8	50	6	●
4.5	2.25R	10	50	6	●
5	2.5R	10	50	6	●
5.5	2.75R	12	50	6	●
6	3R	12	50	6	●
6.5	3.25R	14	60	8	●
7	3.5R	14	60	8	●
7.5	3.75R	14	60	8	●
8	4R	14	60	8	●
8.5	4.25R	18	72	10	●
9	4.5R	18	72	10	●
9.5	4.75R	18	72	10	●
10	5R	18	72	10	●
11	5.5R	22	75	12	●
12	6R	22	75	12	●
13	6.5R	26	90	16	●
14	7R	26	90	16	●
15	7.5R	30	90	16	●
16	8R	30	100	16	●
17	8.5R	34	100	20	●
18	9R	34	100	20	●
19	9.5R	38	100	20	●
20	10R	38	100	20	●

Work Material

P	H	M	K	N	S
●	●	○	●	○	○

P	Steel
----------	-------

H	<38HRC Hardened Steel
----------	--------------------------

H	<48HRC Hardened Steel
----------	--------------------------

M	Stainless Steel
----------	-----------------

K	Cast Iron
----------	-----------

N	Copper
----------	--------

Feature of product:

Ball Nose End Mills- 2 Flutes
Suitable to work on various kind of materials.

Nano multilayer coating enable to enhance wear resistance.

S shape ball nose geometry design enable to keep cutting stable.

Suitable to work on material below HRC48.

General processing

Work Material		GR.1 Carbon Steel		GR.2 Low-alloyed Steel (~24HRC)		GR.3 Hi-alloyed Steel (~30HRC)		GR.4 Hardened Steel (30~38HRC)		GR.5 Hardened Steel (38~48HRC)		GR.8 Stainless Steel		GR.9 Cast Iron		GR.11 Copper	
Vc m/min		Ø0.1~0.6 20~60 Ø0.8~20 80~120		Ø0.1~0.6 20~60 Ø0.8~20 80~120		Ø0.1~0.6 20~60 Ø0.8~20 80~100		Ø0.1~0.6 20~60 Ø0.8~20 60~80		Ø0.1~0.6 20~60 Ø0.8~20 60~70		Ø0.1~0.6 20~60 Ø0.8~20 60~80		Ø0.1~0.6 20~60 Ø0.8~20 80~120		Ø0.1~0.6 25~75 Ø0.8~20 100~120	
Code No.	Dc	RPM	Feed	RPM	Feed	RPM	Feed	RPM	Feed	RPM	Feed	RPM	Feed	RPM	Feed	RPM	Feed
		(min-1)	(mm/min)	(min-1)	(mm/min)	(min-1)	(mm/min)	(min-1)	(mm/min)	(min-1)	(mm/min)	(min-1)	(mm/min)	(min-1)	(mm/min)	(min-1)	(mm/min)
B222X-R0.05	0.1	32,000	140	32,000	140	32,000	140	32,000	120	32,000	120	32,000	100	32,000	140	40,000	180
B222X-R0.1	0.2	32,000	160	32,000	160	32,000	160	32,000	140	32,000	140	32,000	120	32,000	160	40,000	200
B222X-R0.15	0.3	32,000	200	32,000	200	32,000	200	32,000	200	32,000	200	32,000	200	32,000	200	40,000	300
B222X-R0.2	0.4	32,000	296	32,000	296	32,000	330	32,000	330	32,000	205	32,000	330	32,000	296	40,000	490
B222X-R0.25	0.5	32,000	395	32,000	395	32,000	330	32,000	330	32,000	205	32,000	330	32,000	395	40,000	490
B222X-R0.3	0.6	32,000	490	32,000	490	32,000	400	32,000	400	32,000	265	32,000	400	32,000	490	40,000	580
B222X-R0.4	0.8	32,000	550	32,000	550	31,500	406	31,500	406	27,500	290	31,500	406	32,000	550	40,000	660
B222X-R0.5	1	31,500	564	31,500	564	25,000	412	25,000	412	22,000	296	25,000	412	31,500	564	32,000	700
B222X-R0.6	1.2	29,190	570	29,190	570	23,880	410	23,880	410	18,580	300	21,250	410	29,195	570	31,850	710
B222X-R0.75	1.5	26,250	578	26,250	578	20,860	418	20,860	418	14,800	302	20,860	418	26,250	578	25,500	715
B222X-R0.9	1.8	21,230	580	21,230	580	17,690	424	17,690	424	12,380	305	17,690	420	23,000	580	23,000	720
B222X-R1	2	21,000	582	21,000	582	16,720	425	16,720	425	11,000	310	16,720	425	21,000	582	19,000	730
B222X-R1.25	2.5	15,750	596	15,750	596	12,580	430	12,580	430	8,900	316	12,580	430	15,750	596	12,700	745
B222X-R1.5	3	10,500	620	10,500	620	8,450	435	8,450	435	7,400	322	8,450	435	10,500	620	12,500	760
B222X-R1.75	3.5	9,840	625	9,840	625	7,350	440	7,350	440	6,400	330	7,350	440	9,840	625	11,000	760
B222X-R2	4	9,250	630	9,250	630	6,350	442	6,350	442	5,550	342	6,350	442	9,250	630	9,500	765
B222X-R1.25	4.5	8,600	635	8,600	635	5,700	445	5,700	445	5,100	355	5,700	445	8,600	635	8,600	770
B222X-R2.5	5	7,950	640	7,950	640	5,095	447	5,095	447	4,460	377	5,095	447	7,950	640	7,650	775
B222X-R2.75	5.5	6,600	645	6,600	645	4,650	450	4,650	450	4,050	380	4,650	450	6,600	645	6,950	780
B222X-R3	6	5,300	670	5,300	670	4,200	465	4,200	465	3,700	390	4,200	465	5,300	670	6,300	800
B222X-R3.5	7	4,600	730	4,600	730	3,700	510	3,700	510	3,200	420	3,700	510	4,600	730	5,500	870
B222X-R4	8	3,950	790	3,950	790	3,150	555	3,150	555	2,750	455	3,150	555	3,950	790	4,750	950
B222X-R4.5	9	3,550	765	3,550	765	2,825	540	2,825	540	2,450	440	2,825	540	3,550	765	4,250	920
B222X-R5	10	3,150	745	3,150	745	2,500	525	2,500	525	2,200	430	2,500	525	3,150	745	3,800	890
B222X-R5.5	11	2,900	720	2,900	720	2,300	505	2,300	505	2,000	430	2,300	505	2,900	720	3,470	865
B222X-R6	12	2,650	700	2,650	700	2,100	490	2,100	490	1,850	430	2,100	490	2,650	700	3,170	840
B222X-R6.5	13	2,450	655	2,450	655	1,960	460	1,960	460	1,730	400	1,960	460	2,450	655	2,970	790
B222X-R7	14	2,300	610	2,300	610	1,830	430	1,830	430	1,620	375	1,830	430	2,300	610	2,780	730
B222X-R7.5	15	2,150	565	2,150	565	1,700	400	1,700	400	1,500	350	1,700	400	2,150	565	2,590	680
B222X-R8	16	1,990	525	1,990	525	1,580	370	1,580	370	1,390	325	1,580	370	1,990	525	2,400	630
B222X-R8.5	17	1,890	495	1,890	495	1,500	350	1,500	350	1,320	305	1,500	350	1,890	495	2,270	590
B222X-R9	18	1,790	470	1,790	470	1,420	330	1,420	330	1,250	290	1,420	330	1,790	470	2,150	560
B222X-R9.5	19	1,690	445	1,690	445	1,340	310	1,340	310	1,180	275	1,340	310	1,690	445	2,020	530
B222X-R10	20	1,590	420	1,590	420	1,260	290	1,260	290	1,110	260	1,260	290	1,590	420	1,900	500
		ap:0.1D		ap:0.1D		ap:0.1D		ap:0.1D		ap:0.1D		ap:0.1D		ap:0.1D		ap:0.1D	
		ae:<1 0.1D ≥1 0.2D		ae:<1 0.1D ≥1 0.2D		ae:<1 0.1D ≥1 0.2D		ae:<1 0.1D ≥1 0.2D		ae:<1 0.05D ≥1 0.1D		ae:<1 0.05D ≥1 0.1D		ae:<1 0.1D ≥1 0.2D		ae:<1 0.1D ≥1 0.2D	

1. Please work with good rigidity / high precision facilities and collet chuck.
2. Please choose proper cutting fluid.
3. The cutting data is reference value only. Please adjust it according to your real working conditions.
4. If RPM is lower the reference value, the Feed rate (fz) and RPM should be reduced by the same proportion.
5. If vibration occurs during cutting, please reduce cutting parameter.

B232X / B242X / B246X

Ball Nose End Mills

MG
Carbide

AlTiN
X-NaNo



Type of Operation



Work Material

P	H	M	K	N	S
●	●	○	●	○	○

P Steel

H <38HRC
Hardened Steel

H <48HRC
Hardened Steel

M Stainless Steel

K Cast Iron

N Copper

Feature of product:

Ball Nose End Mills with Long Length- 2 Flutes

Suitable to work on various kind of materials.

Nano multilayer coating enable to enhance wear resistance.

S shape ball nose geometry design enable to keep cutting stable.

Suitable to work on material below HRC48.

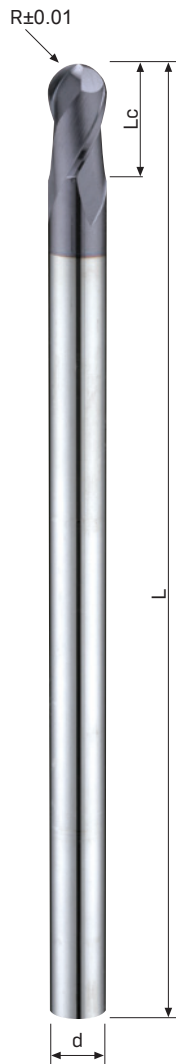
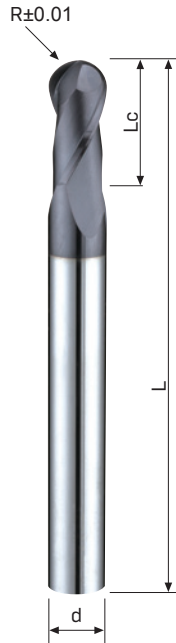

Code No. B232X-Dc

Dc	R	Lc	L	d	AlTiN
$\begin{matrix} 0 \\ -0.02 \end{matrix}$	±0.01	mm	mm	h6	B232X
1	0.5R	2	50	6	●
1.5	0.75R	3	50	6	●
2	1R	4	60	6	●
2.5	1.25R	5	60	6	●
3	1.5R	6	70	6	●
4	2R	8	70	6	●
5	2.5R	10	80	6	●
6	3R	12	80	6	●
7	3.5R	14	100	8	●
8	4R	14	100	8	●
9	4.5R	18	100	10	●
10	5R	18	100	10	●
12	6R	22	110	12	●
14	7R	26	120	16	●
16	8R	30	140	16	●
20	10R	38	160	20	●

Code No. B242X-Dc

Dc	R	Lc	L	d	AlTiN
$\begin{matrix} 0 \\ -0.02 \end{matrix}$	±0.01	mm	mm	h6	B242X
1	0.5R	2	70	3	●
2	1R	4	70	3	●
3	1.5R	6	80	4	●
4	2R	8	80	4	●
5	2.5R	10	100	6	●
6	3R	12	100	6	●
8	4R	14	130	8	●
10	5R	18	160	10	●
12	6R	22	180	12	●
16	8R	30	210	16	●
20	10R	38	210	20	●

Code No. B246X-Dc

Dc	R	Lc	L	d	AlTiN
$\begin{matrix} 0 \\ -0.02 \end{matrix}$	±0.01	mm	mm	h6	B246X
2	1R	4	100	3	●
4	2R	8	130	4	●
6	3R	12	160	6	●
8	4R	14	180	8	●
10	5R	18	200	10	●
12	6R	22	210	12	●

General processing

Work Material		GR.1 Carbon Steel		GR.2 Low-alloyed Steel (~24HRC)		GR.3 Hi-alloyed Steel (~30HRC)		GR.4 Hardened Steel (30-38HRC)		GR.5 Hardened Steel (38-48HRC)		GR.8 Stainless Steel		GR.9 Cast Iron		GR.11 Copper	
Vc m/min		100		100		65		65		55		65		100		100	
Code No.	Dc	RPM (min-1)	Feed (mm/min)	RPM (min-1)	Feed (mm/min)	RPM (min-1)	Feed (mm/min)	RPM (min-1)	Feed (mm/min)	RPM (min-1)	Feed (mm/min)	RPM (min-1)	Feed (mm/min)	RPM (min-1)	Feed (mm/min)	RPM (min-1)	Feed (mm/min)
B232X/B242X-R0.5	1	25,200	480	25,200	480	20,000	320	20,000	320	17,600	225	20,000	320	25,200	480	25,600	560
B232X-R0.75	1.5	16,640	480	16,640	480	13,600	320	13,600	320	11,840	225	13,600	320	16,640	480	20,400	560
B232X/B242X/B246X-R1	2	12,400	480	12,400	480	10,000	320	10,000	320	8,800	230	10,000	320	12,400	480	15,200	560
B232X-R1.25	2.5	12,400	480	12,400	480	8,160	320	8,160	320	7,120	230	8,160	320	12,400	480	10,160	560
B232X/B242X-R1.5	3	8,400	500	8,400	500	6,760	325	6,760	325	5,920	230	6,760	325	8,400	500	10,000	608
B232X/B242X/B246X-R2	4	6,360	500	6,360	500	5,080	355	5,080	355	4,440	300	5,080	355	6,360	500	7,600	608
B232X/B242X-R2.5	5	6,360	500	6,360	500	4,070	355	4,070	355	3,568	300	4,070	355	6,360	500	6,120	608
B232X/B242X/B246X-R3	6	4,240	535	4,240	535	3,360	370	3,360	370	2,960	310	3,360	370	4,240	535	5,040	640
B232X/B242X/B246X-R4	8	3,160	630	3,160	630	2,520	445	2,520	445	2,200	360	2,520	445	3,160	630	3,800	760
B232X/B242X/B246X-R5	10	2,520	600	2,520	600	2,000	420	2,000	420	1,760	340	2,000	420	2,520	600	3,040	710
B232X/B242X/B246X-R6	12	2,120	560	2,120	560	1,680	390	1,680	390	1,480	340	1,680	390	2,120	560	2,530	670
B232X/B242X-R8	16	1,590	420	1,590	420	1,260	295	1,260	295	1,110	260	1,260	295	1,590	420	1,920	500
B232X/B242X-R10	20	1,270	335	1,270	335	1,000	230	1,000	230	888	200	1,000	230	1,270	335	1,520	400
		ap:0.1D		ap:0.1D		ap:0.1D		ap:0.1D		ap:0.1D		ap:0.1D		ap:0.1D		ap:0.1D	
		ae:0.2D		ae:0.2D		ae:0.2D		ae:0.2D		ae:0.1D		ae:0.1D		ae:0.2D		ae:0.2D	

※ Notice: B242X&B246X is Long Length series End Mills. Please adjust the parameter according

1. Please work with good rigidity / high precision facilities and collet chuck.
2. Please choose proper cutting fluid.
3. The cutting data is reference value only. Please adjust it according to your real working conditions.
4. If RPM is lower the reference value, the Feed rate (fz) and RPM should be reduced by the same proportion.
5. If vibration occurs during cutting, please reduce cutting parameter.

B262TX / B263TX / B264TX

Ball Nose End Mills

SMG
CarbideAlTiSiN
TX

Type of Operation



Work Material

P	H	M	K	N	S
●	●	●	○	●	●

P Steel

H <38HRC
Hardened SteelH <48HRC
Hardened SteelH <56HRC
Hardened SteelH <68HRC
Hardened Steel

K Cast Iron

Feature of product:

Ball Nose End Mills with Standard & Long Length- 2 Flutes

Using SMG carbide material and Nano multilayer coating enable to enhance lubrication and wear resistance.

S shape ball nose geometry with small cutting edge design enable to keep longer tool life.

Suitable to work on high hardness material in finishing process.

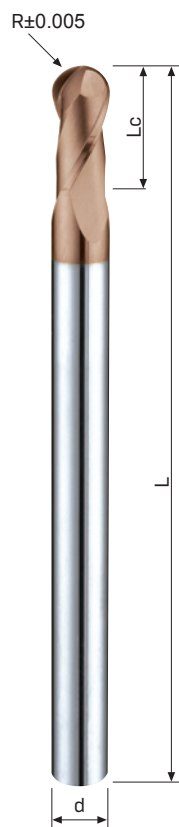
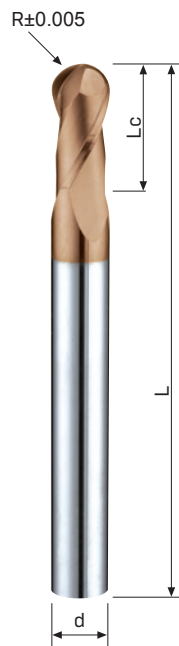
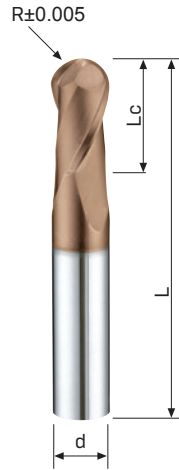

Code No. B262TX-Dc

Dc	R	Lc	L	d	AlTiSiN B262TX
$\begin{matrix} 0 \\ -0.02 \end{matrix}$	± 0.005	mm	mm	h6	
0.1	0.05R	0.2	50	4	●
0.2	0.1R	0.4	50	4	●
0.3	0.15R	0.6	50	4	●
0.4	0.2R	0.8	50	4	●
0.5	0.25R	1	50	4	●
0.6	0.3R	1.2	50	4	●
0.8	0.4R	1.6	50	4	●
1	0.5R	2	50	4	●
1.5	0.75R	3	50	4	●
2	1R	4	50	4	●
2.5	1.25R	5	50	4	●
3A	1.5R	6	50	4	●
4A	2R	8	50	4	●
3	1.5R	6	50	6	●
4	2R	8	50	6	●
5	2.5R	10	50	6	●
6	3R	12	50	6	●
7	3.5R	14	60	8	●
8	4R	14	60	8	●
9	4.5R	18	72	10	●
10	5R	18	72	10	●
12	6R	22	75	12	●
14	7R	26	90	16	●
16	8R	30	100	16	●
20	10R	38	100	20	●

Code No. B263TX-Dc

Dc	R	Lc	L	d	AlTiSiN B263TX
$\begin{matrix} 0 \\ -0.02 \end{matrix}$	± 0.005	mm	mm	h6	
1	0.5R	2	50	6	●
1.5	0.75R	3	50	6	●
2	1R	4	60	6	●
2.5	1.25R	5	60	6	●
3	1.5R	6	70	6	●
4	2R	8	70	6	●
5	2.5R	10	80	6	●
6	3R	12	80	6	●
7	3.5R	14	100	8	●
8	4R	14	100	8	●
9	4.5R	18	100	10	●
10	5R	18	100	10	●
12	6R	22	110	12	●
14	7R	26	120	16	●
16	8R	30	140	16	●
20	10R	38	160	20	●

Code No. B264TX-Dc

Dc	R	Lc	L	d	AlTiSiN B264TX
$\begin{matrix} 0 \\ -0.02 \end{matrix}$	± 0.005	mm	mm	h6	
1	0.5R	2	70	3	●
2	1R	4	70	3	●
3	1.5R	6	80	4	●
4	2R	8	80	4	●
5	2.5R	10	100	6	●
6	3R	12	100	6	●
8	4R	14	130	8	●
10	5R	18	160	10	●
12	6R	22	180	12	●
16	8R	30	210	16	●
20	10R	38	210	20	●

General processing

Work Material		GR.1 Carbon Steel		GR.2 Low-alloyed Steel (~24HRC)		GR.3 Hi-alloyed Steel (~30HRC)		GR.4 Hardened Steel (30~38HRC)		GR.5 Hardened Steel (38~48HRC)		GR.6 Hardened Steel (48~56HRC)		GR.7 Hardened Steel (56~68HRC)	
Vc m/min		Ø0.1~0.6 30~60 Ø0.8~20 80~120		Ø0.1~0.6 30~60 Ø0.8~20 80~120		Ø0.1~0.6 30~60 Ø0.8~20 80~100		Ø0.1~0.6 30~60 Ø0.8~20 73~80		Ø0.1~0.6 30~60 Ø0.8~20 65~70		Ø0.1~0.6 23~46 Ø0.8~20 48~60		Ø0.1~0.6 20~35 Ø0.8~20 35~42	
Code No.	Dc	RPM (min-1)	Feed (mm/min)	RPM (min-1)	Feed (mm/min)	RPM (min-1)	Feed (mm/min)	RPM (min-1)	Feed (mm/min)	RPM (min-1)	Feed (mm/min)	RPM (min-1)	Feed (mm/min)	RPM (min-1)	Feed (mm/min)
B262TX-R0.05	0.1	32,000	320	32,000	320	32,000	300	32,000	250	24,500	160	24,500	100	24,500	50
B262TX-R0.1	0.2	32,000	360	32,000	360	32,000	320	32,000	280	24,500	180	24,500	100	24,500	75
B262TX-R0.15	0.3	32,000	400	32,000	400	32,000	365	32,000	300	32,000	180	24,500	100	24,500	75
B262TX-R0.2	0.4	32,000	450	32,000	450	32,000	400	32,000	320	32,000	200	24,500	130	24,500	115
B262TX-R0.25	0.5	32,000	485	32,000	485	32,000	440	32,000	360	32,000	230	24,500	150	24,500	130
B262TX-R0.3	0.6	32,000	530	32,000	530	31,500	480	32,000	400	32,000	260	24,500	170	23,500	150
B262TX-R0.4	0.8	32,000	605	32,000	605	31,500	550	29,000	400	27,000	270	19,000	185	14,000	140
B262TX/B263TX/B264TX-R0.5	1	32,000	680	32,000	680	31,500	620	25,000	400	22,000	280	19,000	200	14,000	130
B262TX/B263TX-R0.75	1.5	32,000	680	32,000	680	31,500	620	25,000	400	22,000	280	19,000	200	14,000	130
B262TX/B263TX/B264TX-R1	2	19,000	765	19,000	765	15,500	620	12,500	400	11,000	290	9,500	200	7,100	135
B262TX/B263TX-R1.25	2.5	19,000	765	19,000	765	15,500	620	12,500	400	11,000	290	9,500	200	6,360	135
B262TX/B236TX/B264TX-R1.5	3	12,500	765	12,500	765	10,500	630	8,450	400	7,400	290	6,350	200	4,700	140
B262TX/B236TX/B264TX-R2	4	9,500	765	9,500	765	7,950	630	6,350	450	5,550	370	4,750	270	3,500	170
B262TX/B236TX/B264TX-R2.5	5	7,600	850	7,600	850	6,350	630	5,050	450	4,450	370	3,800	280	2,860	170
B262TX/B236TX/B264TX-R3	6	6,350	850	6,350	850	5,300	650	4,200	460	3,700	390	3,150	290	2,300	175
B262TX/B263TX-R3.5	7	5,050	950	5,050	950	4,650	710	3,650	500	3,200	420	2,750	305	2,000	190
B262TX/B236TX/B264TX-R4	8	4,750	1,050	4,750	1,050	3,950	780	3,150	550	2,750	450	2,350	325	1,700	200
B262TX/B263TX-R4.5	9	4,250	1,000	4,250	1,000	3,550	760	2,850	535	2,450	440	2,120	330	1,550	200
B262TX/B236TX/B264TX-R5	10	3,800	950	3,800	950	3,150	740	2,500	525	2,200	430	1,900	330	1,400	200
B262TX/B236TX/B264TX-R6	12	3,150	890	3,150	890	2,650	700	2,100	490	1,850	430	1,550	310	1,100	190
B262TX/B263TX-R7	14	2,700	860	2,700	860	2,250	670	1,800	475	1,550	380	1,350	300	955	180
B262TX/B236TX/B264TX-R8	16	2,350	840	2,350	840	1,950	640	1,550	475	1,350	380	1,150	265	835	175
B262TX/B236TX/B264TX-R10	20	1,900	760	1,900	760	1,750	570	1,400	450	1,100	350	955	250	665	170
		ap:<1 0.05D ≥1 0.1D		ap:<1 0.05D ≥1 0.1D		ap:<1 0.05D ≥1 0.1D		ap:<1 0.05D ≥1 0.1D		ap:<1 0.05D ≥1 0.1D		ap:0.05D		ap:0.05D	
		ae:<1 0.1D ≥1 0.1D		ae:<1 0.1D ≥1 0.1D		ae:<1 0.1D ≥1 0.1D		ae:<1 0.1D ≥1 0.1D		ae:<1 0.1D ≥1 0.1D		ae:0.075D		ae:0.075D	

High-speed machining

Work Material		GR.1 Carbon Steel		GR.2 Low-alloyed Steel (~24HRC)		GR.3 Hi-alloyed Steel (~30HRC)		GR.4 Hardened Steel (30~38HRC)		GR.5 Hardened Steel (38~48HRC)		GR.6 Hardened Steel (48~56HRC)		GR.7 Hardened Steel (56~68HRC)	
Vc m/min		Ø1~3 157~198 Ø4~20 226~300		Ø1~3 157~198 Ø4~20 226~300		Ø1~3 155~165 Ø4~20 195~250		Ø1~3 140~160 Ø4~20 188~220		Ø1~3 125~153 Ø4~20 170~180		Ø1~3 100~113 Ø4~20 138~180		Ø1~3 79~92 Ø4~20 119~126	
Code No.	Dc	RPM (min-1)	Feed (mm/min)	RPM (min-1)	Feed (mm/min)	RPM (min-1)	Feed (mm/min)	RPM (min-1)	Feed (mm/min)	RPM (min-1)	Feed (mm/min)	RPM (min-1)	Feed (mm/min)	RPM (min-1)	Feed (mm/min)
B262TX/B263TX/B264TX-R0.5	1	50,000	2,800	50,000	2,800	50,000	2,800	50,000	2,500	47,500	2,200	32,000	1,400	25,000	1,000
B262TX/B263TX-R0.75	1.5	41,800	2,800	41,800	2,800	33,000	2,800	30,000	2,500	26,500	2,200	24,000	1,400	19,500	1,000
B262TX/B263TX/B264TX-R1	2	31,500	3,500	31,500	3,500	25,000	2,800	24,500	2,500	23,500	2,250	17,000	1,500	12,500	1,000
B262TX/B263TX-R1.25	2.5	41,800	3,500	41,800	3,500	21,000	2,800	20,000	25,000	19,500	2,200	14,000	1,500	10,000	950
B262TX/B236TX/B264TX-R1.5	3	21,000	3,500	21,000	3,500	16,500	2,800	16,000	2,500	15,500	2,200	11,000	1,500	8,400	950
B262TX/B236TX/B264TX-R2	4	18,000	3,700	18,000	3,700	15,500	3,200	15,000	2,700	13,500	2,400	11,000	1,900	7,900	1,000
B262TX/B236TX/B264TX-R2.5	5	15,500	4,000	15,500	4,000	15,000	4,000	14,000	2,800	11,000	2,300	10,000	2,000	7,600	1,200
B262TX/B236TX/B264TX-R3	6	15,000	4,800	15,000	4,800	13,500	4,300	11,500	2,700	9,500	2,200	9,500	2,200	6,600	1,050
B262TX/B236TX/B264TX-R4	8	11,500	3,600	11,500	3,600	10,000	3,200	8,900	2,000	7,100	1,700	7,100	1,700	4,900	880
B262TX/B236TX/B264TX-R5	10	9,500	3,000	9,500	3,000	8,200	2,500	7,100	1,700	5,700	1,300	5,700	1,300	3,900	700
B262TX/B236TX/B264TX-R6	12	7,900	2,450	7,900	2,450	6,800	2,100	5,900	1,350	4,700	1,000	4,700	1,000	3,300	580
B262TX/B236TX/B264TX-R8	16	5,900	1,800	5,900	1,800	5,000	1,500	4,500	1,000	3,500	800	3,500	800	2,450	400
B262TX/B236TX/B264TX-R10	20	4,700	1,300	4,700	1,300	4,000	1,200	3,500	800	2,800	650	2,800	650	2,000	320
		ap:0.02D		ap:0.02D		ap:0.02D		ap:0.02D		ap:0.02D		ap:0.02D		ap:0.02D	
		ae:0.02D		ae:0.02D		ae:0.02D		ae:0.02D		ae:0.02D		ae:0.02D		ae:0.02D	

※ Notice: B263TX/B264TX is Long Length series End Mills. Please adjust the parameter according

B272ATX / B273ATX

Ball Nose End Mills

SMG
CarbideAlTiSiN
ATX

Type of Operation



Work Material

P	H	M	K	N	S
	●				

H	<48HRC Hardened Steel
---	--------------------------

H	<56HRC Hardened Steel
---	--------------------------

H	<68HRC Hardened Steel
---	--------------------------

Feature of product:

Ball Nose End Mills with Standard & Long Length- 2 Flutes

Using SMG carbide material and Nano multilayer coating enable to enhance lubrication and wear resistance.

S shape ball nose geometry with small cutting edge design enable to keep longer tool life.

High radius precision of ball nose suitable to work on high hardness and high precision mold process.

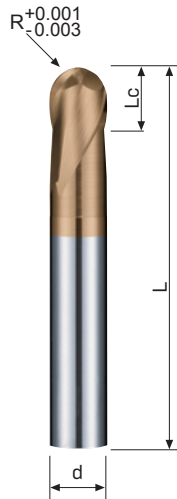

Code No. B272ATX-Dc

Dc	R	Lc	L	d	AlTiSiN
0 -0.02	+0.001 -0.003	mm	mm	h5	B272ATX
0.1	0.05R	0.1	40	4	●
0.2	0.1R	0.2	40	4	●
0.3	0.15R	0.3	40	4	●
0.4	0.2R	0.4	40	4	●
0.5	0.25R	0.5	40	4	●
0.6	0.3R	0.6	40	4	●
0.8	0.3R	0.8	40	4	●
1	0.5R	1	40	4	●
1.5	0.75R	1.5	40	4	●
2	1R	2	45	6	●
2.5	1.25R	2.5	45	6	●
3	1.5R	3	45	6	●
4	2R	4	45	6	●
5	2.5R	5	50	6	●
6	3R	6	50	6	●
8	4R	8	60	8	●
10	5R	10	72	10	●
12	6R	12	75	12	●

※ Suitable in: Heat-shrinkage shank

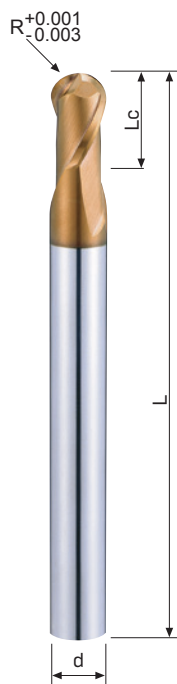

Code No. B273ATX-Dc

Dc	R	Lc	L	d	AlTiSiN
0 -0.02	+0.001 -0.003	mm	mm	h5	B273ATX
1	0.5R	1.5	50	4	●
1.5	0.75R	2.5	50	4	●
2	1R	3	50	6	●
2.5	1.25R	4	50	6	●
3	1.5R	4.5	70	6	●
4	2R	6	70	6	●
5	2.5R	7.5	80	6	●
6	3R	9	80	6	●
8	4R	12	100	8	●
10	5R	15	100	10	●
12	6R	18	110	12	●

Finishing

Work Material		GR.5 Hardened Steel (38~48HRC)		GR.6 Hardened Steel (48~56HRC)		GR.7 Hardened Steel (56~68HRC)	
Vc m/min		130		120		90	
Code No.	Dc	RPM (min ⁻¹)	Feed (mm/min)	RPM (min ⁻¹)	Feed (mm/min)	RPM (min ⁻¹)	Feed (mm/min)
B272ATX-R0.25	0.5	20,000	700	17,000	650	17,000	600
B272ATX/B273ATX-R0.5	1	20,000	800	15,000	750	15,000	750
B272ATX/B273ATX-R0.75	1.5	18,000	1,400	15,000	900	14,000	900
B272ATX/B273ATX-R1	2	15,000	1,600	14,000	1,200	14,000	1,260
B273ATX-R1.25	2.5	14,000	1,700	13,000	1,500	10,000	1,200
B272ATX/B273ATX-R1.5	3	13,000	1,700	12,500	1,500	10,000	1,200
B272ATX/B273ATX-R2	4	11,000	1,680	10,000	1,560	7,200	1,080
B272ATX/B273ATX-R2.5	5	10,000	1,600	9,600	1,440	6,800	1,080
B272ATX/B273ATX-R3	6	6,900	1,450	6,400	1,280	4,800	960
B272ATX/B273ATX-R4	8	5,200	1,200	4,800	1,060	3,600	790
B272ATX/B273ATX-R5	10	4,100	1,030	3,800	910	2,900	700
B272ATX/B273ATX-R6	12	3,500	910	3,200	800	2,400	600
		ap:0.02D		ap:0.02D		ap:0.02D	
		ae:0.02D		ae:0.02D		ae:0.02D	

High-speed machining

Work Material		GR.5 Hardened Steel (38~48HRC)		GR.6 Hardened Steel (48~56HRC)		GR.7 Hardened Steel (56~68HRC)	
Vc m/min		235		130		115	
Code No.	Dc	RPM (min ⁻¹)	Feed (mm/min)	RPM (min ⁻¹)	Feed (mm/min)	RPM (min ⁻¹)	Feed (mm/min)
B272ATX-R0.25	0.5	50,000	1,450	40,000	1,100	40,000	900
B272ATX/B273ATX-R0.5	1	30,000	1,700	24,000	2,000	21,000	1,700
B272ATX/B273ATX-R0.75	1.5	30,000	2,400	17,000	2,000	15,000	1,700
B272ATX/B273ATX-R1	2	28,000	2,800	14,000	2,100	12,200	1,800
B273ATX-R1.25	2.5	24,000	2,850	12,500	2,100	10,500	1,800
B272ATX/B273ATX-R1.5	3	21,000	3,000	10,500	2,200	9,000	1,750
B272ATX/B273ATX-R2	4	18,000	3,200	9,000	2,300	7,900	2,000
B272ATX/B273ATX-R2.5	5	15,500	3,300	7,800	2,500	6,800	2,000
B272ATX/B273ATX-R3	6	13,000	3,450	6,500	2,500	5,700	2,200
B272ATX/B273ATX-R4	8	9,500	3,000	5,200	2,100	4,500	1,900
B272ATX/B273ATX-R5	10	7,500	2,500	4,200	1,800	3,700	1,700
B272ATX/B273ATX-R6	12	6,200	2,000	3,600	1,700	3,100	1,450
		ap:0.02D		ap:0.02D		ap:0.02D	
		ae:0.02D		ae:0.02D		ae:0.02D	

1. Please work with good rigidity / high precision facilities and collet chuck.
2. Please choose proper cutting fluid.
3. The cutting data is reference value only. Please adjust it according to your real working conditions.
4. If RPM is lower the reference value, the Feed rate [fz] and RPM should be reduced by the same proportion.
5. If vibration occurs during cutting, please reduce cutting parameter.

B251TX

Ball Nose End Mills

SMG Carbide **AlTiSiN TX**



Type of Operation

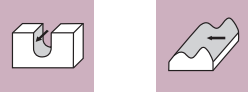

Work Material

P	H	M	K	N	S
	●				

H <48HRC
Hardened Steel

H <56HRC
Hardened Steel

H <68HRC
Hardened Steel

Feature of product:

Ball Nose Short Groove End Mills-
Micro

Using SMG carbide material and Nano multilayer coating enable to enhance lubrication and wear resistance.

S shape ball nose geometry with small cutting edge design enable to keep longer tool life.

The smallest diameter up to 0.1mm, suitable to work on high hardness and high precision mold process.

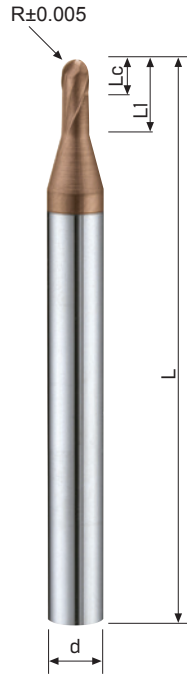

Code No. B251TX-Dc

Dc	R	Lc	L	d	L1	AlTiSiN B251TX
0 -0.02	±0.005	mm	mm	h6	mm	●
0.1	0.05R	0.1	50	4	0.3	●
0.2	0.1R	0.2	50	4	0.5	●
0.3	0.15R	0.3	50	4	0.8	●
0.4	0.2R	0.4	50	4	1	●
0.5	0.25R	0.5	50	4	1.3	●
0.6	0.3R	0.6	50	4	1.5	●
0.8	0.4R	0.8	50	4	2	●
1	0.5R	1	50	4	2.5	●
1.5	0.75R	1.5	50	4	3.8	●
2	1R	2	50	6	5	●
3	1.5R	3	60	6	8	●
4	2R	4	60	6	10	●
5	2.5R	5	60	6	12	●
6	3R	6	60	6	15	●

Finishing

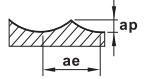
Work Material		GR.5 Hardened Steel (38~48HRC)		GR.6 Hardened Steel (48~56HRC)		GR.7 Hardened Steel (56~68HRC)	
Vc m/min		130		120		90	
Code No.	Dc	RPM (min ⁻¹)	Feed (mm/min)	RPM (min ⁻¹)	Feed (mm/min)	RPM (min ⁻¹)	Feed (mm/min)
B251TX-R0.15	0.3	40,000	500	30,000	400	30,000	350
B251TX-R0.2	0.4	40,000	500	30,000	400	30,000	350
B251TX-R0.25	0.5	40,000	600	30,000	500	30,000	400
B251TX-R0.3	0.6	30,000	600	30,000	500	30,000	500
B251TX-R0.4	0.8	30,000	700	20,000	600	30,000	600
B251TX-R0.5	1	20,000	800	15,000	750	15,000	750
B251TX-R0.75	1.5	18,000	1,400	15,000	900	14,000	900
B251TX-R1	2	15,000	1,600	14,000	1,200	14,000	1,260
B251TX-R1.5	3	13,000	1,700	12,500	1,500	10,000	1,200
B251TX-R2	4	11,000	1,680	10,000	1,560	7,200	1,080
B251TX-R2.5	5	10,000	1,600	9,600	1,440	6,800	1,080
B251TX-R3	6	6,900	1,450	6,400	1,280	4,800	960
(mm) 	ap:0.02D		ap:0.02D		ap:0.02D		
	ae:0.02D		ae:0.02D		ae:0.02D		

High-speed machining

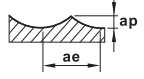
Work Material		GR.5 Hardened Steel (38~48HRC)		GR.6 Hardened Steel (48~56HRC)		GR.7 Hardened Steel (56~68HRC)	
Vc m/min		200		175		120	
Code No.	Dc	RPM (min ⁻¹)	Feed (mm/min)	RPM (min ⁻¹)	Feed (mm/min)	RPM (min ⁻¹)	Feed (mm/min)
B251TX-R0.15	0.3	50,000	950	40,000	720	40,000	600
B251TX-R0.2	0.4	50,000	1,200	40,000	900	40,000	800
B251TX-R0.25	0.5	50,000	1,400	40,000	1,000	40,000	930
B251TX-R0.3	0.6	50,000	1,600	40,000	1,200	40,000	1,300
B251TX-R0.4	0.8	50,000	2,000	40,000	1,500	40,000	1,400
B251TX-R0.5	1	50,000	2,500	40,000	1,900	32,000	1,400
B251TX-R0.75	1.5	46,000	3,000	32,000	2,000	25,000	1,600
B251TX-R1	2	35,000	3,300	25,000	2,500	20,000	1,750
B251TX-R1.5	3	23,000	3,200	19,000	2,500	13,000	1,800
B251TX-R2	4	17,500	3,300	14,000	2,500	9,800	1,600
B251TX-R2.5	5	14,000	3,300	11,000	2,500	7,900	1,700
B251TX-R3	6	11,500	3,000	9,500	2,500	6,500	1,700
(mm) 	ap:0.02D		ap:0.02D		ap:0.02D		
	ae:0.02D		ae:0.02D		ae:0.02D		

1. Please work with good rigidity / high precision facilities and collet chuck.
2. Please choose proper cutting fluid.
3. The cutting data is reference value only. Please adjust it according to your real working conditions.
4. If RPM is lower the reference value, the Feed rate [fz] and RPM should be reduced by the same proportion.
5. If vibration occurs during cutting, please reduce cutting parameter.

B261TX

Ball Nose End Mills

SMG
CarbideAlTiSiN
TX

Type of Operation



Work Material

P	H	M	K	N	S
	●				

H	<48HRC Hardened Steel
---	--------------------------

H	<56HRC Hardened Steel
---	--------------------------

H	<68HRC Hardened Steel
---	--------------------------

Feature of product:

Ball Nose End Mills with Standard & Long Length- 2 Flutes

Using SMG carbide material and Nano multilayer coating enable to enhance lubrication and wear resistance.

S shape ball nose geometry with small cutting edge design enable to keep longer tool life.

Suitable to work on high hardness and high precision mold process.

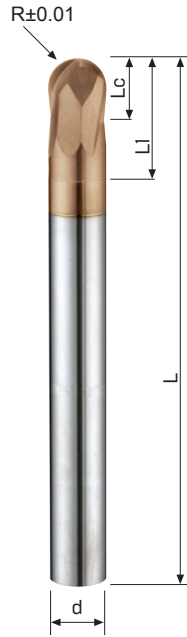

Code No. B261TX-Dc

Dc	R	Lc	L	d	L1	AlTiSiN B261TX
0 -0.02	±0.01	mm	mm	h6	mm	
1	0.5R	1	50	4	2	●
1.5	0.75R	1.5	50	4	3	●
2	1R	2	60	6	4	●
3	1.5R	3	70	6	6	●
4	2R	4	70	6	8	●
5	2.5R	5	80	6	10	●
6	3R	6	80	6	12	●
8	4R	8	100	8	16	●
10	5R	10	100	10	20	●
12	6R	12	110	12	24	●

Finishing

Work Material		GR.5 Hardened Steel (38-48HRC)		GR.6 Hardened Steel (48-56HRC)		GR.7 Hardened Steel (56-68HRC)	
Vc m/min		230		200		180	
Code No.	Dc	RPM (min-1)	Feed (mm/min)	RPM (min-1)	Feed (mm/min)	RPM (min-1)	Feed (mm/min)
B261TX-R0.5	1	40,000	1,000	31,500	800	23,000	600
B261TX-R0.75	1.5	34,000	1,000	26,000	800	19,200	600
B261TX-R1	2	26,500	1,300	22,000	1,000	16,200	800
B261TX-R1.5	3	25,500	2,300	21,000	1,800	15,500	1,500
B261TX-R2	4	21,000	2,350	17,300	1,800	12,800	1,400
B261TX-R2.5	5	18,000	2,300	14,800	1,850	11,000	1,380
B261TX-R3	6	12,000	2,300	10,500	2,000	9,500	1,800
B261TX-R4	8	9,100	1,700	7,900	1,500	7,100	1,300
B261TX-R5	10	7,300	1,400	6,300	1,200	5,700	1,000
B261TX-R6	12	6,000	1,200	5,300	1,000	4,700	950
		ap:0.02D		ap:0.02D		ap:0.02D	
		ae:0.02D		ae:0.02D		ae:0.02D	

High-speed machining

Work Material		GR.5 Hardened Steel (38-48HRC)		GR.6 Hardened Steel (48-56HRC)		GR.7 Hardened Steel (56-68HRC)	
Vc m/min		320		250		180	
Code No.	Dc	RPM (min-1)	Feed (mm/min)	RPM (min-1)	Feed (mm/min)	RPM (min-1)	Feed (mm/min)
B261TX-R3	6	17,500	4,000	13,000	3,000	10,000	2,000
B261TX-R4	8	13,000	3,000	9,800	2,300	7,500	1,500
B261TX-R5	10	10,500	2,500	7,900	1,800	6,000	1,200
B261TX-R6	12	8,700	2,000	6,600	1,500	5,000	1,000
		ap:0.02D		ap:0.02D		ap:0.02D	
		ae:0.02D		ae:0.02D		ae:0.02D	

1. Please work with good rigidity / high precision facilities and collet chuck.
2. Please choose proper cutting fluid.
3. The cutting data is reference value only. Please adjust it according to your real working conditions.
4. If RPM is lower the reference value, the Feed rate [fz] and RPM should be reduced by the same proportion.
5. If vibration occurs during cutting, please reduce cutting parameter.

B253TX / B254TX

Ball Nose End Mills - 3 / 4 Flutes

Type of Operation

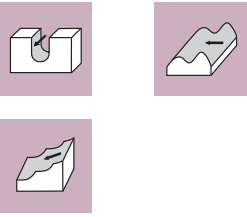

Work Material

P	H	M	K	N	S
	●		○		○

H <48HRC Hardened Steel

H <56HRC Hardened Steel

H <68HRC Hardened Steel

K Cast Iron

S Titanium

S Nickel

S High Temp Alloys

Feature of product:

B253TX Ball Nose End Mills- 3 Flutes

B254TX Ball Nose End Mills- 4 Flutes

Using SMG carbide material and Nano multilayer coating enable to enhance lubrication and wear resistance.

S shape ball nose geometry with small cutting edge design enable to keep tool life longer.

High radius precision of ball nose suitable to work on high hardness and high precision mold process.

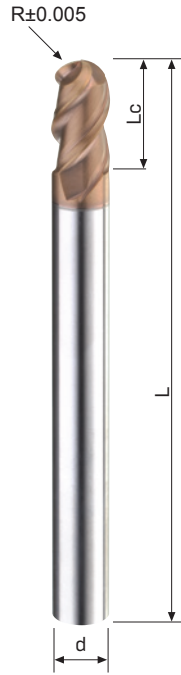

SMG Carbide

AlTiSiN TX



Code No. B253TX-Dc

Dc 0 -0.02	R ±0.005	Lc mm	L mm	d h6	AlTiSiN B253TX
6	3	12	80	6	●
8	4	14	100	8	●
10	5	18	100	10	●
12	6	22	110	12	●

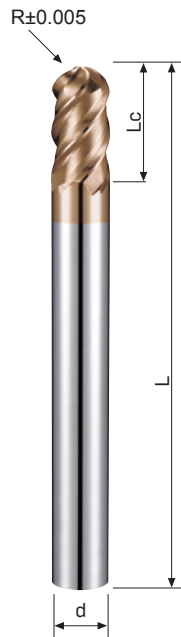

SMG Carbide

AlTiSiN TX



Code No. B254TX-Dc

Dc 0 -0.02	R ±0.005	Lc mm	L mm	d h6	AlTiSiN B254TX
3	1.5R	6	70	6	●
4	2R	8	70	6	●
5	2.5R	10	80	6	●
6	3R	12	80	6	●
8	4R	14	100	8	●
10	5R	18	100	10	●
12	6R	22	110	12	●
16	8R	30	140	16	●
20	10R	38	160	20	●

High feed machining

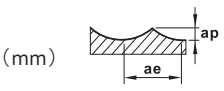
Work Material		GR.5 Hardened Steel (38-48HRC)		GR.6 Hardened Steel (48-56HRC)		GR.7 Hardened Steel (56-68HRC)	
Code No.	Dc	RPM (min-1)	Feed (mm/min)	RPM (min-1)	Feed (mm/min)	RPM (min-1)	Feed (mm/min)
B253TX-R3	6	8000~3200	2700~1200	6400~2500	1900~830	4800~1900	1500~700
B253TX-R4	8	6000~2400	2600~1000	4800~1900	1900~800	3800~1500	1500~600
B253TX-R5	10	4800~1900	3400~1400	3800~1500	2400~1000	3000~1000	1600~800
B253TX-R6	12	4000~1600	2400~1000	3200~1300	1700~1100	2200~800	1350~600
	ap:0.075~0.015		ap:0.075~0.015		ap:0.075~0.015		
	ae:0.2~0.18		ae:0.2~0.18		ae:0.2~0.18		

Finishing

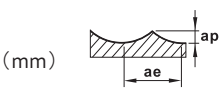
Work Material		GR.5 Hardened Steel (38-48HRC)		GR.6 Hardened Steel (48-56HRC)		GR.7 Hardened Steel (56-68HRC)	
Vc m/min		280		220		200	
Code No.	Dc	RPM (min-1)	Feed (mm/min)	RPM (min-1)	Feed (mm/min)	RPM (min-1)	Feed (mm/min)
B254TX-R1.5	3	29,000	6,560	23,000	4,500	21,100	4,240
B254TX-R2	4	22,000	6,250	17,100	4,000	15,800	3,520
B254TX-R2.5	5	17,500	5,600	13,600	3,500	12,700	3,200
B254TX-R3	6	15,000	5,000	11,400	3,000	10,600	2,500
B254TX-R4	8	11,000	4,200	8,550	2,500	7,950	2,250
B254TX-R5	10	9,000	3,500	6,850	2,150	6,350	2,000
B254TX-R6	12	7,500	3,000	5,700	2,000	5,300	1,900
B254TX-R8	16	5,500	3,000	4,280	2,000	4,000	1,900
B254TX-R10	20	4,500	3,000	3,500	2,000	3,200	1,900
	ap:0.02D		ap:0.02D		ap:0.02D		
	ae:0.05D		ae:0.05D		ae:0.05D		

1. Please work with good rigidity / high precision facilities and collet chuck.
2. Please choose proper cutting fluid.
3. The cutting data is reference value only. Please adjust it according to your real working conditions.
4. If RPM is lower the reference value, the Feed rate (fz) and RPM should be reduced by the same proportion.
5. If vibration occurs during cutting, please reduce cutting parameter.

B250TX

Ball Nose End Mills

UMG Carbide **AlTiSiN TX**



Type of Operation



Work Material

P	H	M	K	N	S
●	●	●	○	●	●

P Steel

H <38HRC Hardened Steel

H <48HRC Hardened Steel

H <56HRC Hardened Steel

H <68HRC Hardened Steel

K Cast Iron

Feature of product:

Ball Nose End Mills- 2 Flutes

Using UMG carbide material and Nano multilayer coating enable to enhance lubrication and wear resistance.

S shape ball nose geometry with side taper cutting edge design, suitable to work on high hardness and high precision mold process.

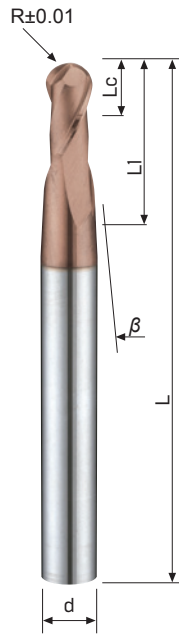

Code No. B250TX-R×β



















R	β	Lc	L	d	L1	AlTiSiN B250TX
±0.01	on Side	mm	mm	h6	mm	
0.5R	1° 30'	2	60	6	23	●
0.5R	5°	2	60	6	23	●
0.5R	3°	2	80	6	42	●
1R	1° 30'	4	60	6	23	●
1R	5°	4	60	6	23	●
1R	3°	4	80	6	41	●
1.5R	3°	6	70	6	32	●
1.5R	1° 30'	6	90	6	52	●
2R	3°	8	70	6	28	●
2R	1° 30'	8	90	6	49	●
2.5R	3°	10	90	8	41	●
2.5R	1° 30'	10	110	8	61	●
3R	3°	12	90	8	34	●
3R	1° 30'	12	110	8	53	●
4R	3°	14	100	10	36	●
4R	1° 30'	14	120	10	55	●
5R	3°	18	110	12	40	●
5R	1° 30'	18	130	12	59	●
6R	3°	22	140	16	63	●
6R	1° 30'	22	160	16	83	●

General processing

Work Material		GR.1 Carbon Steel		GR.2 Low-alloyed Steel (~24HRC)		GR.3 Hi-alloyed Steel (~30HRC)		GR.4 Hardened Steel (30~38HRC)		GR.5 Hardened Steel (38~48HRC)		GR.6 Hardened Steel (48~56HRC)	
Vc m/min		85		85		65		65		45		30	
Code No.	Dc	RPM (min-1)	Feed (mm/min)	RPM (min-1)	Feed (mm/min)	RPM (min-1)	Feed (mm/min)	RPM (min-1)	Feed (mm/min)	RPM (min-1)	Feed (mm/min)	RPM (min-1)	Feed (mm/min)
B250TX-R0.5	1	20,000	125	20,000	125	15,000	120	15,000	120	11,000	65	7,100	30
B250TX-R1	2	11,000	130	11,000	130	85,000	120	85,000	120	6,400	70	4,000	40
B250TX-R1.5	3	5,900	230	5,900	230	5,000	190	5,000	190	3,500	90	2,150	45
B250TX-R2	4	5,300	310	5,300	310	4,200	230	4,200	230	2,950	90	1,850	55
B250TX-R2.5	5	4,400	305	4,400	305	3,500	230	3,500	230	2,450	100	1,500	55
B250TX-R3	6	3,300	290	3,300	290	2,600	230	2,600	230	1,850	95	1,200	50
B250TX-R4	8	2,600	275	2,600	275	2,100	220	2,100	220	1,450	95	950	50
B250TX-R5	10	2,200	275	2,200	275	1,750	220	1,750	220	1,200	90	800	45
B250TX-R6	12	2,650	700	2,650	700	2,100	490	2,100	490	1,850	430	2,100	490
<p>(mm)</p>		ap:1.5D		ap:1.5D		ap:1.5D		ap:1.5D		ap:1.5D		ap:1.5D	
		ae:0.02D		ae:0.02D		ae:0.02D		ae:0.02D		ae:0.02D		ae:0.02D	

1. Please work with good rigidity / high precision facilities and collet chuck.
2. Please choose proper cutting fluid.
3. The cutting data is reference value only. Please adjust it according to your real working conditions.
4. If RPM is lower the reference value, the Feed rate (fz) and RPM should be reduced by the same proportion.
5. If vibration occurs during cutting, please reduce cutting parameter.

End Mills With Corner Radius

Page	129	131	133	135	137	139
Apperance						
Code No	B255X	B257X	B256X	B258X	B286TX	B275TX
Carbide	UMG Carbide	UMG Carbide	UMG Carbide	UMG Carbide	SMG Carbide	SMG Carbide
Coating	AlTiN X-NaNo	AlTiN X-NaNo	AlTiN X-NaNo	AlTiN X-NaNo	AlTiSiN TX	AlTiSiN TX
Helix Angle	 30°	 30°	 30°	 30°	 45°	 45°
No.of Flutes	 2	 2	 4	 4	 4	 4

ASIA

141

143

143

145

147



B277TX

B259TX

B269TX

B271TX

E105X

**SMG
Carbide**

**SMG
Carbide**

**SMG
Carbide**

**SMG
Carbide**

**UMG
Carbide**

**AlTiSiN
TX**

**AlTiSiN
TX**

**AlTiSiN
TX**

**AlTiSiN
TX**

**AlTiN
X-NaNo**



B255X

End Mills With Corner Radius

Code No. B255X-Dc×R

UMG
CarbideAlTiN
X-NaNo

Type of Operation

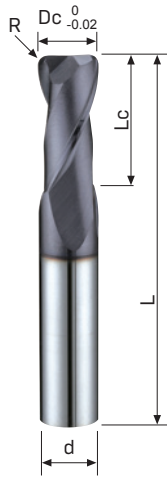

Dc	R	Lc	L	d	AlTiN B255X
$0_{-0.02}$	± 0.01	mm	mm	h6	
1	R0.1	3	50	4	●
1	R0.2	3	50	4	●
1	R0.3	3	50	4	●
1.5	R0.1	5	50	4	●
1.5	R0.2	5	50	4	●
1.5	R0.3	5	50	4	●
1.5	R0.5	5	50	4	●
2	R0.1	6	50	4	●
2	R0.2	6	50	4	●
2	R0.3	6	50	4	●
2	R0.5	6	50	4	●
2.5	R0.1	8	50	4	●
2.5	R0.2	8	50	4	●
2.5	R0.3	8	50	4	●
2.5	R0.5	8	50	4	●
3A	R0.1	8	50	4	●
3A	R0.2	8	50	4	●
3A	R0.3	8	50	4	●
3A	R0.5	8	50	4	●
4A	R0.1	11	50	4	●
4A	R0.2	11	50	4	●
4A	R0.3	11	50	4	●
4A	R0.5	11	50	4	●
4A	R1	11	50	4	●
3	R0.1	8	50	6	●
3	R0.2	8	50	6	●
3	R0.3	8	50	6	●
3	R0.5	8	50	6	●
4	R0.1	11	50	6	●
4	R0.2	11	50	6	●
4	R0.3	11	50	6	●
4	R0.5	11	50	6	●
4	R1	11	50	6	●
5	R0.2	13	50	6	●
5	R0.3	13	50	6	●
5	R0.5	13	50	6	●
5	R1	13	50	6	●
6	R0.2	16	50	6	●
6	R0.3	16	50	6	●
6	R0.5	16	50	6	●
6	R1	16	50	6	●
6	R1.5	16	50	6	●
6	R2	16	50	6	●
8	R0.2	20	60	8	●
8	R0.3	20	60	8	●
8	R0.5	20	60	8	●
8	R1	20	60	8	●
8	R1.5	20	60	8	●
8	R2	20	60	8	●
8	R3	20	60	8	●
10	R0.2	22	72	10	●
10	R0.3	22	72	10	●
10	R0.5	22	72	10	●
10	R1	22	72	10	●
10	R1.5	22	72	10	●
10	R2	22	72	10	●
10	R3	22	72	10	●

Dc	R	Lc	L	d	AlTiN B255X
$0_{-0.02}$	± 0.01	mm	mm	h6	
12	R0.2	26	75	12	●
12	R0.3	26	75	12	●
12	R0.5	26	75	12	●
12	R1	26	75	12	●
12	R1.5	26	75	12	●
12	R2	26	75	12	●
12	R3	26	75	12	●
16	R0.5	38	100	16	●
16	R1	38	100	16	●
16	R1.5	38	100	16	●
16	R2	38	100	16	●
16	R3	38	100	16	●
16	R4	38	100	16	●
20	R0.5	38	100	20	●
20	R1	38	100	20	●
20	R1.5	38	100	20	●
20	R2	38	100	20	●
20	R3	38	100	20	●
20	R4	38	100	20	●
20	R5	38	100	20	●

Work Material

P	H	M	K	N	S
●	●	○	●	○	○

P	Steel
---	-------

H	<38HRC Hardened Steel
---	--------------------------

H	<48HRC Hardened Steel
---	--------------------------

H	<56HRC Hardened Steel
---	--------------------------

M	Stainless Steel
---	-----------------

K	Cast Iron
---	-----------

N	Copper
---	--------

Feature of product:

End Mills with Corner Radius- 2
Flutes

Widely used in roughing 3D curved
profile and normal processing.

Coating with AlTiN to have perfect
wear resistance.

Suitable for various steel
materials up to HRC56.

Slotting

Work Material		GR.1 Carbon Steel		GR.2 Low-alloyed Steel (~24HRC)		GR.3 Hi-alloyed Steel (~30HRC)		GR.4 Hardened Steel (30~38HRC)		GR.5 Hardened Steel (38~48HRC)		GR.6 Hardened Steel (48~56HRC)		GR.9 Cast Iron	
Vc m/min		Ø1.0~3.0 62~70 Ø3.1~20 75~80		Ø1.0~3.0 62~70 Ø3.1~20 75~80		Ø1.0~3.0 62~70 Ø3.1~20 75~80		Ø1.0~3.0 40~50 Ø3.1~20 53~55		Ø1.0~3.0 34~40 Ø3.1~20 44~50		Ø1.0~3.0 22~25 Ø3.1~20 28~30		Ø1.0~3.0 62~70 Ø3.1~20 75~80	
Code No.	Dc	RPM (min-1)	Feed (mm/min)	RPM (min-1)	Feed (mm/min)	RPM (min-1)	Feed (mm/min)	RPM (min-1)	Feed (mm/min)	RPM (min-1)	Feed (mm/min)	RPM (min-1)	Feed (mm/min)	RPM (min-1)	Feed (mm/min)
B255X-1	1	19,500	120	19,500	120	14,500	120	12,500	85	11,000	65	7,000	30	19,500	120
B255X-1.5	1.5	14,000	120	14,000	120	10,500	120	8,500	85	8,000	65	5,000	40	14,000	120
B255X-2	2	11,000	130	11,000	130	8,350	120	7,000	85	6,300	70	3,900	40	11,000	130
B255X-2.5	2.5	9,900	115	9,900	115	7,000	130	6,000	85	5,000	70	3,500	40	9,900	115
B255X-3	3	7,500	190	7,500	190	6,350	150	5,300	100	4,350	75	2,700	40	7,500	190
B255X-4	4	6,000	225	6,000	225	4,900	180	4,200	120	3,500	90	2,200	50	6,000	225
B255X-5	5	5,200	300	5,200	300	4,300	230	3,500	125	3,000	100	1,900	55	5,200	300
B255X-6	6	4,500	300	4,500	300	3,600	230	2,900	120	2,500	100	1,600	55	4,500	300
B255X-8	8	3,300	280	3,300	280	2,700	230	2,200	120	1,900	100	1,100	50	3,300	280
B255X-10	10	2,600	270	2,600	270	2,100	220	1,700	120	1,500	90	950	50	2,600	270
B255X-12	12	2,200	270	2,200	270	1,800	210	1,450	125	1,200	95	800	45	2,200	270
B255X-16	16	1,600	250	1,600	250	1,350	190	1,100	100	950	85	600	35	1,600	250
B255X-20	20	1,300	200	1,300	200	1,050	150	880	75	750	65	480	30	1,300	200
(mm)		ap: ≤3 0.3D >3 0.5D		ap: ≤3 0.3D >3 0.5D		ap: ≤3 0.3D >3 0.5D		ap: ≤3 0.3D >3 0.5D		ap: ≤3 0.3D >3 0.5D		ap : 0.05D		ap: ≤3 0.3D >3 0.5D	

1. Please work with good rigidity / high precision facilities and collet chuck.
2. Please choose proper cutting fluid.
3. The cutting data is reference value only. Please adjust it according to your real working conditions.
4. If RPM is lower the reference value, the Feed rate (fz) and RPM should be reduced by the same proportion.
5. If vibration occurs during cutting, please reduce cutting parameter.

B257X

End Mills With Corner Radius

Code No. B257X-Dc×R

UMG Carbide **AlTiN X-NaNo**



Type of Operation



Work Material

P	H	M	K	N	S
●	●	○	●	○	○

P	Steel
----------	-------

H	<38HRC Hardened Steel
----------	--------------------------

H	<48HRC Hardened Steel
----------	--------------------------

H	<56HRC Hardened Steel
----------	--------------------------

M	Stainless Steel
----------	-----------------

K	Cast Iron
----------	-----------

N	Copper
----------	--------

Feature of product:

End Mills with Corner Radius- 2
Flutes · Long Length

Widely used in roughing 3D curved
profile and normal processing.

Coating with AlTiN to have perfect
wear resistance.

Suitable for various steel
materials up to HRC56.

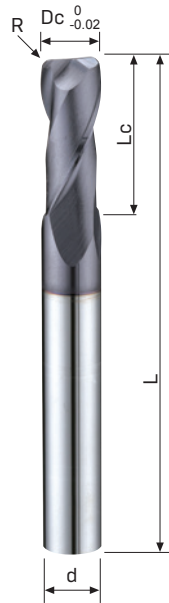

Dc 0 -0.02	R ±0.01	Lc mm	L mm	d h6	AlTiN B257X
3	R0.1	10	50	3	●
3	R0.2	10	50	3	●
3	R0.3	10	50	3	●
3	R0.5	10	50	3	●
4	R0.1	15	60	4	●
4	R0.2	15	60	4	●
4	R0.3	15	60	4	●
4	R0.5	15	60	4	●
4	R1	15	60	4	●
5	R0.2	18	70	5	●
5	R0.3	18	70	5	●
5	R0.5	18	70	5	●
5	R1	18	70	5	●
6	R0.2	20	80	6	●
6	R0.3	20	80	6	●
6	R0.5	20	80	6	●
6	R1	20	80	6	●
6	R1.5	20	80	6	●
6	R2	20	80	6	●
8	R0.2	25	100	8	●
8	R0.3	25	100	8	●
8	R0.5	25	100	8	●
8	R1	25	100	8	●
8	R1.5	25	100	8	●
8	R2	25	100	8	●
8	R3	25	100	8	●
10	R0.2	30	100	10	●
10	R0.3	30	100	10	●
10	R0.5	30	100	10	●
10	R1	30	100	10	●
10	R1.5	30	100	10	●
10	R2	30	100	10	●
10	R3	30	100	10	●
12	R0.2	40	110	12	●
12	R0.3	40	110	12	●
12	R0.5	40	110	12	●
12	R1	40	110	12	●
12	R1.5	40	110	12	●
12	R2	40	110	12	●
12	R3	40	110	12	●
16	R0.5	50	140	16	●
16	R1	50	140	16	●
16	R1.5	50	140	16	●
16	R2	50	140	16	●
16	R3	50	140	16	●
16	R4	50	140	16	●
20	R0.5	60	160	20	●
20	R1	60	160	20	●
20	R1.5	60	160	20	●
20	R2	60	160	20	●
20	R3	60	160	20	●
20	R4	60	160	20	●
20	R5	60	160	20	●

Slotting

Work Material		GR.1 Carbon Steel		GR.2 Low-alloyed Steel (~24HRC)		GR.3 Hi-alloyed Steel (~30HRC)		GR.4 Hardened Steel (30~38HRC)		GR.5 Hardened Steel (38~48HRC)		GR.6 Hardened Steel (48~56HRC)		GR.9 Cast Iron	
Vc m/min		80		80		80		55		50		30		80	
Code No.	Dc	RPM (min-1)	Feed (mm/min)	RPM (min-1)	Feed (mm/min)	RPM (min-1)	Feed (mm/min)	RPM (min-1)	Feed (mm/min)	RPM (min-1)	Feed (mm/min)	RPM (min-1)	Feed (mm/min)	RPM (min-1)	Feed (mm/min)
B257X-3	3	7,500	190	7,500	190	6,350	150	5,300	100	4,350	75	2,700	40	7,500	190
B257X-4	4	6,000	225	6,000	225	4,900	180	4,200	120	3,500	90	2,200	50	6,000	225
B257X-5	5	5,200	300	5,200	300	4,300	230	3,500	125	3,000	100	1,900	55	5,200	300
B257X-6	6	4,500	300	4,500	300	3,600	230	2,900	120	2,500	100	1,600	55	4,500	300
B257X-8	8	3,300	280	3,300	280	2,700	230	2,200	120	1,900	100	1,100	50	3,300	280
B257X-10	10	2,600	270	2,600	270	2,100	220	1,700	120	1,500	90	950	50	2,600	270
B257X-12	12	2,200	270	2,200	270	1,800	210	1,450	125	1,200	95	800	45	2,200	270
B257X-16	16	1,600	250	1,600	250	1,350	190	1,100	100	950	85	600	35	1,600	250
B257X-20	20	1,300	200	1,300	200	1,050	150	880	75	750	65	480	30	1,300	200
(mm)		ap:0.5D		ap:0.5D		ap:0.5D		ap:0.5D		ap:0.5D		ap : 0.05D		ap:0.5D	

1. Please work with good rigidity / high precision facilities and collet chuck.
2. Please choose proper cutting fluid.
3. The cutting data is reference value only. Please adjust it according to your real working conditions.
4. If RPM is lower the reference value, the Feed rate [fz] and RPM should be reduced by the same proportion.
5. If vibration occurs during cutting, please reduce cutting parameter.

B256X

End Mills With Corner Radius

Code No. B256X-Dc×R

UMG
CarbideAlTiN
X-NaNo

Type of Operation



Work Material

P	H	M	K	N	S
●	●	○	●	○	○

P	Steel
---	-------

H	<38HRC Hardened Steel
---	--------------------------

H	<48HRC Hardened Steel
---	--------------------------

H	<56HRC Hardened Steel
---	--------------------------

M	Stainless Steel
---	-----------------

K	Cast Iron
---	-----------

N	Copper
---	--------

Feature of product:

End Mills with Corner Radius- 4
Flutes

Widely used in roughing and
finishing 3D curved profile.

Coating with AlTiN to have perfect
wear resistance.

Suitable for various steel
materials up to HRC56.

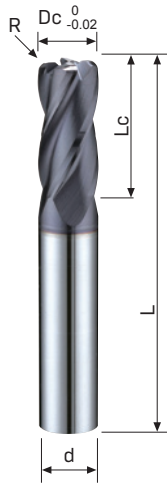

Dc	R	Lc	L	d	AlTiN B256X
$0_{-0.02}$	± 0.01	mm	mm	h6	
1	R0.1	3	50	4	●
1	R0.2	3	50	4	●
1	R0.3	3	50	4	●
1.5	R0.1	5	50	4	●
1.5	R0.2	5	50	4	●
1.5	R0.3	5	50	4	●
1.5	R0.5	5	50	4	●
2	R0.1	6	50	4	●
2	R0.2	6	50	4	●
2	R0.3	6	50	4	●
2	R0.5	6	50	4	●
2.5	R0.1	8	50	4	●
2.5	R0.2	8	50	4	●
2.5	R0.3	8	50	4	●
2.5	R0.5	8	50	4	●
3A	R0.1	8	50	4	●
3A	R0.2	8	50	4	●
3A	R0.3	8	50	4	●
3A	R0.5	8	50	4	●
4A	R0.1	11	50	4	●
4A	R0.2	11	50	4	●
4A	R0.3	11	50	4	●
4A	R0.5	11	50	4	●
4A	R1	11	50	4	●
3	R0.1	8	50	6	●
3	R0.2	8	50	6	●
3	R0.3	8	50	6	●
3	R0.5	8	50	6	●
4	R0.1	11	50	6	●
4	R0.2	11	50	6	●
4	R0.3	11	50	6	●
4	R0.5	11	50	6	●
4	R1	11	50	6	●
5	R0.2	13	50	6	●
5	R0.3	13	50	6	●
5	R0.5	13	50	6	●
5	R1	13	50	6	●
6	R0.2	16	50	6	●
6	R0.3	16	50	6	●
6	R0.5	16	50	6	●
6	R1	16	50	6	●
6	R1.5	16	50	6	●
6	R2	16	50	6	●
8	R0.2	20	60	8	●
8	R0.3	20	60	8	●
8	R0.5	20	60	8	●
8	R1	20	60	8	●
8	R1.5	20	60	8	●
8	R2	20	60	8	●
8	R3	20	60	8	●
10	R0.2	22	72	10	●
10	R0.3	22	72	10	●
10	R0.5	22	72	10	●
10	R1	22	72	10	●
10	R1.5	22	72	10	●
10	R2	22	72	10	●
10	R3	22	72	10	●

Dc	R	Lc	L	d	AlTiN B256X
$0_{-0.02}$	± 0.01	mm	mm	h6	
12	R0.2	26	75	12	●
12	R0.3	26	75	12	●
12	R0.5	26	75	12	●
12	R1	26	75	12	●
12	R1.5	26	75	12	●
12	R2	26	75	12	●
12	R3	26	75	12	●
16	R0.5	38	100	16	●
16	R1	38	100	16	●
16	R1.5	38	100	16	●
16	R2	38	100	16	●
16	R3	38	100	16	●
16	R4	38	100	16	●
20	R0.5	38	100	20	●
20	R1	38	100	20	●
20	R1.5	38	100	20	●
20	R2	38	100	20	●
20	R3	38	100	20	●
20	R4	38	100	20	●
20	R5	38	100	20	●

Side Milling

Work Material		GR.1 Carbon Steel		GR.2 Low-alloyed Steel (~24HRC)		GR.3 Hi-alloyed Steel (~30HRC)		GR.4 Hardened Steel (30~38HRC)		GR.5 Hardened Steel (38~48HRC)		GR.6 Hardened Steel (48~56HRC)		GR.9 Cast Iron		
Vc m/min		Ø1.0~2.5 60~80 Ø3.0~20 80~85		Ø1.0~2.5 60~80 Ø3.0~20 80~85		Ø1.0~2.5 47~70 Ø3.0~20 70~75		Ø1.0~1.5 47~57 Ø1.5~20 57~70		Ø1.0~2.5 30~47 Ø3.0~20 50~60		Ø1.0~20 22~30		Ø1.0~2.5 60~80 Ø3.0~20 80~85		
Code No.	Dc	RPM (min-1)	Feed (mm/min)	RPM (min-1)	Feed (mm/min)	RPM (min-1)	Feed (mm/min)	RPM (min-1)	Feed (mm/min)	RPM (min-1)	Feed (mm/min)	RPM (min-1)	Feed (mm/min)	RPM (min-1)	Feed (mm/min)	
B256X-1	1	20,000	240	20,000	240	15,000	215	15,000	215	10,000	85	7,100	40	20,000	240	
B256X-1.5	1.5	13,500	245	13,500	245	12,000	215	12,000	215	8,000	90	5,100	50	13,500	245	
B256X-2	2	13,000	300	13,000	300	11,000	280	11,000	280	7,000	110	3,900	60	13,000	300	
B256X-2.5	2.5	10,000	320	10,000	320	9,000	300	9,000	300	6,000	120	3,000	60	10,000	320	
B256X-3	3	8,800	500	8,800	500	7,200	350	7,200	350	5,300	125	2,700	60	8,800	500	
B256X-4	4	6,600	530	6,600	530	5,500	360	5,500	360	4,200	130	2,200	70	6,600	530	
B256X-5	5	5,300	600	5,300	600	4,350	420	4,350	420	3,500	140	1,900	75	5,300	600	
B256X-6	6	4,500	610	4,500	610	3,700	425	3,700	425	2,900	145	1,500	70	4,500	610	
B256X-8	8	3,300	590	3,300	590	2,700	425	2,700	425	2,200	145	1,100	65	3,300	590	
B256X-10	10	2,600	580	2,600	580	2,200	420	2,200	420	1,700	145	950	65	2,600	580	
B256X-12	12	2,200	580	2,200	580	1,800	420	1,800	420	1,400	140	800	60	2,200	580	
B256X-16	16	1,600	530	1,600	530	1,300	400	1,300	400	1,200	130	600	45	1,600	530	
B256X-20	20	1,300	510	1,300	510	1,100	370	1,100	370	890	110	470	35	1,300	510	
(mm) 	ap:1.5D		ap:1.5D		ap:1.5D		ap:1.5D		ap:1.5D		ap:1.5D		ap:1.5D		ap:1.5D	
	ae:<3 0.05D ≥3 0.1D		ae:<3 0.05D ≥3 0.1D		ae:<3 0.05D ≥3 0.1D		ae:<3 0.05D ≥3 0.1D		ae:<3 0.05D ≥3 0.1D		ae:<3 0.05D ≥3 0.1D		ae:0.02D		ae:<3 0.05D ≥3 0.1D	

1. Please work with good rigidity / high precision facilities and collet chuck.
2. Please choose proper cutting fluid.
3. The cutting data is reference value only. Please adjust it according to your real working conditions.
4. If RPM is lower the reference value, the Feed rate (fz) and RPM should be reduced by the same proportion.
5. If vibration occurs during cutting, please reduce cutting parameter.

B258X

End Mills With Corner Radius

Code No. B258X-Dc×R

UMG Carbide **AlTiN X-NaNo**



Type of Operation

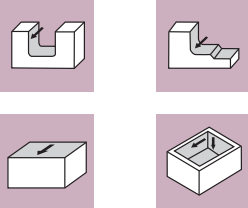

Work Material

P	H	M	K	N	S
●	●	○	●	○	○

P Steel

H <38HRC Hardened Steel

H <48HRC Hardened Steel

H <56HRC Hardened Steel

M Stainless Steel

K Cast Iron

N Copper

Feature of product:

End Mills with Corner Radius- 4 Flutes · Long Length

Widely used in roughing and finishing 3D curved profile.

Coating with AlTiN to have perfect wear resistance.

Suitable for various steel materials up to HRC56.

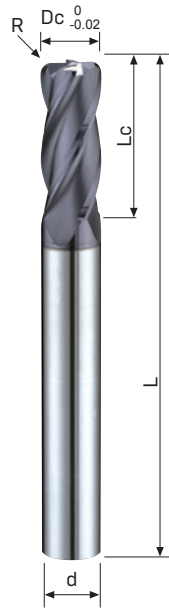

Dc 0 -0.02	R ±0.01	Lc mm	L mm	d h6	AlTiN B258X
3	R0.1	10	50	3	●
3	R0.2	10	50	3	●
3	R0.3	10	50	3	●
3	R0.5	10	50	3	●
4	R0.1	15	60	4	●
4	R0.2	15	60	4	●
4	R0.3	15	60	4	●
4	R0.5	15	60	4	●
4	R1	15	60	4	●
5	R0.2	18	70	5	●
5	R0.3	18	70	5	●
5	R0.5	18	70	5	●
5	R1	18	70	5	●
6	R0.2	20	80	6	●
6	R0.3	20	80	6	●
6	R0.5	20	80	6	●
6	R1	20	80	6	●
6	R1.5	20	80	6	●
6	R2	20	80	6	●
8	R0.2	25	100	8	●
8	R0.3	25	100	8	●
8	R0.5	25	100	8	●
8	R1	25	100	8	●
8	R1.5	25	100	8	●
8	R2	25	100	8	●
8	R3	25	100	8	●
10	R0.2	30	100	10	●
10	R0.3	30	100	10	●
10	R0.5	30	100	10	●
10	R1	30	100	10	●
10	R1.5	30	100	10	●
10	R2	30	100	10	●
10	R3	30	100	10	●
12	R0.2	40	110	12	●
12	R0.3	40	110	12	●
12	R0.5	40	110	12	●
12	R1	40	110	12	●
12	R1.5	40	110	12	●
12	R2	40	110	12	●
12	R3	40	110	12	●
16	R0.5	50	140	16	●
16	R1	50	140	16	●
16	R1.5	50	140	16	●
16	R2	50	140	16	●
16	R3	50	140	16	●
16	R4	50	140	16	●
20	R0.5	60	160	20	●
20	R1	60	160	20	●
20	R1.5	60	160	20	●
20	R2	60	160	20	●
20	R3	60	160	20	●
20	R4	60	160	20	●
20	R5	60	160	20	●

Side Milling

Work Material		GR.1 Carbon Steel		GR.2 Low-alloyed Steel (~24HRC)		GR.3 Hi-alloyed Steel (~30HRC)		GR.4 Hardened Steel (30~38HRC)		GR.5 Hardened Steel (38~48HRC)		GR.6 Hardened Steel (48~56HRC)		GR.9 Cast Iron	
Vc m/min		85		85		75		70		60		30		85	
Code No.	Dc	RPM (min-1)	Feed (mm/min)	RPM (min-1)	Feed (mm/min)	RPM (min-1)	Feed (mm/min)	RPM (min-1)	Feed (mm/min)	RPM (min-1)	Feed (mm/min)	RPM (min-1)	Feed (mm/min)	RPM (min-1)	Feed (mm/min)
B258X-3	3	8,800	500	8,800	500	7,200	350	7,200	350	5,300	125	2,700	60	8,800	500
B258X-4	4	6,600	530	6,600	530	5,500	360	5,500	360	4,200	130	2,200	70	6,600	530
B258X-5	5	5,300	600	5,300	600	4,350	420	4,350	420	3,500	140	1,900	75	5,300	600
B258X-6	6	4,500	610	4,500	610	3,700	425	3,700	425	2,900	145	1,500	70	4,500	610
B258X-8	8	3,300	590	3,300	590	2,700	425	2,700	425	2,200	145	1,100	65	3,300	590
B258X-10	10	2,600	580	2,600	580	2,200	420	2,200	420	1,700	145	950	65	2,600	580
B258X-12	12	2,200	580	2,200	580	1,800	420	1,800	420	1,400	140	800	60	2,200	580
B258X-16	16	1,600	530	1,600	530	1,300	400	1,300	400	1,200	130	600	45	1,600	530
B258X-20	20	1,300	510	1,300	510	1,100	370	1,100	370	890	110	470	35	1,300	510
(mm)		ap:1.5D		ap:1.5D		ap:1.5D		ap:1.5D		ap:1.5D		ap:1.5D		ap:1.5D	
		ae:0.1D		ae:0.1D		ae:0.1D		ae:0.1D		ae:0.1D		ae:0.02D		ae:0.1D	

1. Please work with good rigidity / high precision facilities and collet chuck.
2. Please choose proper cutting fluid.
3. The cutting data is reference value only. Please adjust it according to your real working conditions.
4. If RPM is lower the reference value, the Feed rate [fz] and RPM should be reduced by the same proportion.
5. If vibration occurs during cutting, please reduce cutting parameter.

B286TX

End Mills With Corner Radius

SMG
Carbide

AlTiSiN
TX



Type of Operation



Work Material

P	H	M	K	N	S
●	●	●	●	○	○

P Steel

H <38HRC
Hardened Steel

H <48HRC
Hardened Steel

H <56HRC
Hardened Steel

H <68HRC
Hardened Steel

M Stainless Steel

K Cast Iron

S Titanium

S Nickel

S High Temp Alloys

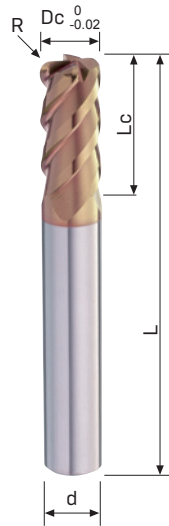

Code No. B286TX-Dc×R

Dc 0 -0.02	R ±0.01	Lc mm	L mm	d h6	AlTiSiN B286TX
1	R0.2	3	50	4	●
1.5	R0.2	5	50	4	●
2	R0.2	6	50	4	●
2	R0.5	6	50	4	●
2.5	R0.2	8	50	4	●
3A	R0.2	8	50	4	●
3A	R0.5	8	50	4	●
4A	R0.2	11	50	4	●
4A	R0.5	11	50	4	●
4A	R1	11	50	4	●
3	R0.2	8	50	6	●
3	R0.5	8	50	6	●
4	R0.2	11	50	6	●
4	R0.5	11	50	6	●
4	R1	11	50	6	●
5	R0.2	13	50	6	●
5	R0.5	13	50	6	●
5	R1	13	50	6	●
6	R0.2	16	50	6	●
6	R0.3	16	50	6	●
6	R0.5	16	50	6	●
6	R1	16	50	6	●
8	R0.2	20	60	8	●
8	R0.3	20	60	8	●
8	R0.5	20	60	8	●
8	R1	20	60	8	●
8	R2	20	60	8	●
10	R0.2	22	72	10	●
10	R0.3	22	72	10	●
10	R0.5	22	72	10	●
10	R1	22	72	10	●
10	R2	22	72	10	●
10	R3	22	72	10	●
12	R0.5	26	75	12	●
12	R1	26	75	12	●
12	R2	26	75	12	●
12	R3	26	75	12	●
16	R1	38	100	16	●
16	R2	38	100	16	●
16	R3	38	100	16	●
20	R1	38	100	20	●
20	R2	38	100	20	●
20	R3	38	100	20	●

Feature of product:

High Performance End Mills with
Corner Radius- 4 Flutes

Using SMG carbide material and
coated multilayer nano coating
to increase lubrication and wear
resistance with good tool life.

High rigidity of the carbide center
and the tool face is designed with
smooth radius angle to reach high
chip removal rate.

Widely used in roughing and
finishing 3D curved profile.

Side Milling

Work Material		GR.1/GR.2 /GR.3 Carbon Steel/Low-alloyed Steel/Hi-alloyed Steel (~24HRC) (~30HRC)		GR.4 /GR.5 Hardened Steel/Hardened Steel (30~38HRC) (38~48HRC)		GR.6 Hardened Steel (48~56HRC)		GR.7 Hardened Steel (56~68HRC)		GR.8 Stainless Steel		GR.9 Cast Iron	
Vc m/min		170		150		100		50		60		150	
Code No.	(Dc)	RPM (min-1)	Feed (mm/min)	RPM (min-1)	Feed (mm/min)	RPM (min-1)	Feed (mm/min)	RPM (min-1)	Feed (mm/min)	RPM (min-1)	Feed (mm/min)	RPM (min-1)	Feed (mm/min)
B286TX-1	1	54145	1083	47775	956	31850	637	8500	50	19110	382	47775	956
B286TX-1.5	1.5	36097	1155	31850	637	21233	425	6000	80	12740	408	31850	637
B286TX-2	2	27073	1624	23888	478	15925	319	4050	100	9555	573	23888	478
B286TX-3	3	18048	1444	15,800	1,200	10,500	820	3,800	120	6370	510	15,800	1,200
B286TX-4	4	13536	1624	12,000	1,300	8,000	800	2,650	135	4778	573	12,000	1,300
B286TX-5	5	10829	1733	9,500	1,300	6,300	850	2,250	140	3822	612	9,500	1,300
B286TX-6	6	9024	1805	8,000	1,200	5,300	820	2,200	175	3185	637	8,000	1,200
B286TX-8	8	6768	1624	6,000	1,100	4,000	750	1,650	185	2389	573	6,000	1,100
B286TX-10	10	5415	1516	4,800	1,100	3,200	745	1,300	165	1911	535	4,800	1,100
B286TX-12	12	4512	1444	4,000	1,065	2,700	740	1,100	145	1593	510	4,000	1,065
B286TX-16	16	3384	1218	3,000	1,000	2,000	730	840	170	1194	430	3,000	1,000
B286TX-20	20	2707	1083	2,400	955	1,600	700	670	170	956	382	2,400	955
	ap:1.0D		ap:1.0D		ap:1.0D		ap:1.0D		ap:1.0D		ap:1.0D		
	ae:0.05D		ae:0.05D		ae:0.03D		ae:0.02D		ae:0.03D		ae:0.05D		

High Speed Side Milling

Work Material		GR.1/GR.2 /GR.3 Carbon Steel/Low-alloyed Steel/Hi-alloyed Steel (~24HRC) (~30HRC)		GR.4 /GR.5 Hardened Steel/Hardened Steel (30~38HRC) (38~48HRC)		GR.6 Hardened Steel (48~56HRC)		GR.7 Hardened Steel (56~68HRC)		GR.8 Stainless Steel		GR.9 Cast Iron	
Vc m/min		250		200		150		100		100		200	
Code No.	(Dc)	RPM (min-1)	Feed (mm/min)	RPM (min-1)	Feed (mm/min)	RPM (min-1)	Feed (mm/min)	RPM (min-1)	Feed (mm/min)	RPM (min-1)	Feed (mm/min)	RPM (min-1)	Feed (mm/min)
B286TX-1	1	79625	1593	63700	700	47000	560	31850	380	31850	700	63700	700
B286TX-1.5	1.5	53083	1699	42400	850	31850	640	21200	430	21200	848	42400	850
B286TX-2	2	39813	2389	31850	1020	23900	956	16000	600	16000	960	31850	1020
B286TX-3	3	26542	2123	21233	850	15925	630	10617	424	10617	849	21233	850
B286TX-4	4	19906	2389	15925	900	11944	630	7963	477	7963	956	15925	900
B286TX-5	5	15925	2548	12740	1000	9555	650	6370	510	6370	1019	12740	1000
B286TX-6	6	13271	2654	10617	1200	7963	700	5308	530	5308	1062	10617	1200
B286TX-8	8	9953	2389	7963	1200	5972	700	3981	530	3981	956	7963	1200
B286TX-10	10	7963	2230	6370	850	4778	630	3185	420	3185	892	6370	850
B286TX-12	12	6635	2123	5308	850	3981	630	2654	420	2654	849	5308	850
B286TX-16	16	4977	1792	3981	900	2986	650	1991	420	1991	717	3981	900
B286TX-20	20	3981	1593	3185	900	2389	650	1593	420	1593	637	3185	900
	ap:1.0D		ap:1.0D		ap:1.0D		ap:1.0D		ap:1.0D		ap:1.0D		
	ae:0.01D		ae:0.01D		ae:0.01D		ae:0.01D		ae:0.03D		ae:0.01D		

1. Please work with good rigidity / high precision facilities and collet chuck.
2. Please choose proper cutting fluid.
3. The cutting data is reference value only. Please adjust it according to your real working conditions.
4. If RPM is lower the reference value, the Feed rate (fz) and RPM should be reduced by the same proportion.
5. If vibration occurs during cutting, please reduce cutting parameter.

B275TX

High Performance End Mills With Corner Radius

SMG
Carbide

AlTiSiN
TX



Type of Operation



Work Material

P	H	M	K	N	S
●	●	●	●	○	○

P Steel

H <38HRC
Hardened Steel

H <48HRC
Hardened Steel

H <56HRC
Hardened Steel

H <68HRC
Hardened Steel

M Stainless Steel

K Cast Iron

S Titanium

S Nickel

S High Temp Alloys

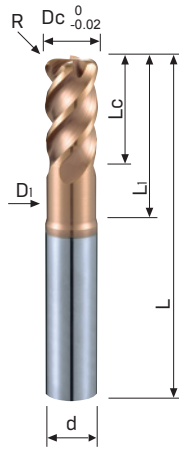

Code No. B275TX-Dc×R

Dc 0 -0.02	R ±0.01	Lc mm	L mm	d h6	Li mm	Di mm	AlTiSiN B275TX
1	R0.2	2	50	4	3	0.9	●
1.5	R0.2	3	50	4	5	1.4	●
2	R0.2	4	50	4	6	1.9	●
3	R0.2	5	50	6	8	2.8	●
3	R0.5	5	50	6	8	2.8	●
4	R0.2	6	50	6	10	3.8	●
4	R0.5	6	50	6	10	3.8	●
5	R0.2	8	50	6	13	4.8	●
5	R0.5	8	50	6	13	4.8	●
6	R0.2	9	50	6	15	5.7	●
6	R0.5	9	50	6	15	5.7	●
6	R1	9	50	6	15	5.7	●
6	R1.5	9	50	6	15	5.7	●
8	R0.2	12	60	8	20	7.6	●
8	R0.5	12	60	8	20	7.6	●
8	R1	12	60	8	20	7.6	●
8	R2	12	60	8	20	7.6	●
10	R0.2	15	75	10	25	9.5	●
10	R0.5	15	75	10	25	9.5	●
10	R1	15	75	10	25	9.5	●
10	R2	15	75	10	25	9.5	●
12	R0.2	18	80	12	30	11.4	●
12	R0.5	18	80	12	30	11.4	●
12	R1	18	80	12	30	11.4	●
12	R2	18	80	12	30	11.4	●
16	R0.5	24	100	16	40	15.2	●
16	R1	24	100	16	40	15.2	●
16	R2	24	100	16	40	15.2	●
16	R3	24	100	16	40	15.2	●
20	R0.5	30	110	20	50	19	●
20	R1	30	110	20	50	19	●
20	R2	30	110	20	50	19	●
20	R3	30	110	20	50	19	●

Feature of product:

High Performance End Mills with
Corner Radius- Short Type

Using SMG carbide material and
coated multilayer nano coating
to increase lubrication and wear
resistance with good tool life.

High precision corner radius
suitable for general & finishing on
high hardness and high precision
mold process.

Side Milling

Work Material		GR.1/GR.2 /GR.3 Carbon Steel/Low-alloyed Steel/Hi-alloyed Steel (~24HRC) (~30HRC)		GR.4 /GR.5 Hardened Steel/Hardened Steel (30-38HRC) (38-48HRC)		GR.6 Hardened Steel (48-56HRC)		GR.7 Hardened Steel (56-68HRC)		GR.8 Stainless Steel		GR.9 Cast Iron	
Vc m/min		170		150		100		50		60		150	
Code No.	(Dc)	RPM (min-1)	Feed (mm/min)	RPM (min-1)	Feed (mm/min)	RPM (min-1)	Feed (mm/min)	RPM (min-1)	Feed (mm/min)	RPM (min-1)	Feed (mm/min)	RPM (min-1)	Feed (mm/min)
B275TX-1	1	54145	1083	47775	956	31850	637	8500	50	19110	382	47775	956
B275TX-1.5	1.5	36097	1155	31850	637	21233	425	6000	80	12740	408	31850	637
B275TX-2	2	27073	1624	23888	478	15925	319	4050	100	9555	573	23888	478
B275TX-3	3	18048	1444	15,800	1,200	10,500	820	3,800	120	6370	510	15,800	1,200
B275TX-4	4	13536	1624	12,000	1,300	8,000	800	2,650	135	4778	573	12,000	1,300
B275TX-5	5	10829	1733	9,500	1,300	6,300	850	2,250	140	3822	612	9,500	1,300
B275TX-6	6	9024	1805	8,000	1,200	5,300	820	2,200	175	3185	637	8,000	1,200
B275TX-8	8	6768	1624	6,000	1,100	4,000	750	1,650	185	2389	573	6,000	1,100
B275TX-10	10	5415	1516	4,800	1,100	3,200	745	1,300	165	1911	535	4,800	1,100
B275TX-12	12	4512	1444	4,000	1,065	2,700	740	1,100	145	1593	510	4,000	1,065
B275TX-16	16	3384	1218	3,000	1,000	2,000	730	840	170	1194	430	3,000	1,000
B275TX-20	20	2707	1083	2,400	955	1,600	700	670	170	956	382	2,400	955
(mm) 	ap:1.0D		ap:1.0D		ap:1.0D		ap:1.0D		ap:1.0D		ap:1.0D		
	ae:0.05D		ae:0.05D		ae:0.03D		ae:0.02D		ae:0.03D		ae:0.05D		

High Speed Side Milling

Work Material		GR.1/GR.2 /GR.3 Carbon Steel/Low-alloyed Steel/Hi-alloyed Steel (~24HRC) (~30HRC)		GR.4 /GR.5 Hardened Steel/Hardened Steel (30-38HRC) (38-48HRC)		GR.6 Hardened Steel (48-56HRC)		GR.7 Hardened Steel (56-68HRC)		GR.8 Stainless Steel		GR.9 Cast Iron	
Vc m/min		250		200		150		100		100		200	
Code No.	(Dc)	RPM (min-1)	Feed (mm/min)	RPM (min-1)	Feed (mm/min)	RPM (min-1)	Feed (mm/min)	RPM (min-1)	Feed (mm/min)	RPM (min-1)	Feed (mm/min)	RPM (min-1)	Feed (mm/min)
B275TX-1	1	79625	1593	63700	700	47000	560	31850	380	31850	700	63700	700
B275TX-1.5	1.5	53083	1699	42400	850	31850	640	21200	430	21200	848	42400	850
B275TX-2	2	39813	2389	31850	1020	23900	956	16000	600	16000	960	31850	1020
B275TX-3	3	26542	2123	21233	850	15925	630	10617	424	10617	849	21233	850
B275TX-4	4	19906	2389	15925	900	11944	630	7963	477	7963	956	15925	900
B275TX-5	5	15925	2548	12740	1000	9555	650	6370	510	6370	1019	12740	1000
B275TX-6	6	13271	2654	10617	1200	7963	700	5308	530	5308	1062	10617	1200
B275TX-8	8	9953	2389	7963	1200	5972	700	3981	530	3981	956	7963	1200
B275TX-10	10	7963	2230	6370	850	4778	630	3185	420	3185	892	6370	850
B275TX-12	12	6635	2123	5308	850	3981	630	2654	420	2654	849	5308	850
B275TX-16	16	4977	1792	3981	900	2986	650	1991	420	1991	717	3981	900
B275TX-20	20	3981	1593	3185	900	2389	650	1593	420	1593	637	3185	900
(mm) 	ap:1.0D		ap:1.0D		ap:1.0D		ap:1.0D		ap:1.0D		ap:1.0D		
	ae:0.01D		ae:0.01D		ae:0.01D		ae:0.01D		ae:0.03D		ae:0.01D		

1. Please work with good rigidity / high precision facilities and collet chuck.
2. Please choose proper cutting fluid.
3. The cutting data is reference value only. Please adjust it according to your real working conditions.
4. If RPM is lower the reference value, the Feed rate (fz) and RPM should be reduced by the same proportion.
5. If vibration occurs during cutting, please reduce cutting parameter.

B277TX

High Performance End Mills With Corner Radius

SMG
Carbide

AlTiSiN
TX



Type of Operation



Work Material

P	H	M	K	N	S
●	●	●	●	○	○

P Steel

H <38HRC
Hardened Steel

H <48HRC
Hardened Steel

H <56HRC
Hardened Steel

H <68HRC
Hardened Steel

M Stainless Steel

K Cast Iron

S Titanium

S Nickel

S High Temp Alloys

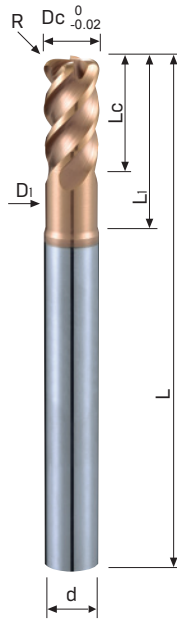

Code No. B277TX-Dc×R

Dc 0 -0.02	R ±0.01	Lc mm	L mm	d h6	L1 mm	D1 mm	AlTiSiN B277TX
6	R0.2	9	80	6	18	5.7	●
6	R0.5	9	80	6	18	5.7	●
6	R1	9	80	6	18	5.7	●
6	R1.5	9	80	6	18	5.7	●
8	R0.2	12	100	8	24	7.6	●
8	R0.5	12	100	8	24	7.6	●
8	R1	12	100	8	24	7.6	●
8	R2	12	100	8	24	7.6	●
10	R0.2	15	100	10	30	9.5	●
10	R0.5	15	100	10	30	9.5	●
10	R1	15	100	10	30	9.5	●
10	R2	15	100	10	30	9.5	●
12	R0.2	18	110	12	36	11.4	●
12	R0.5	18	110	12	36	11.4	●
12	R1	18	110	12	36	11.4	●
12	R2	18	110	12	36	11.4	●
16	R0.5	24	140	16	48	15.2	●
16	R1	24	140	16	48	15.2	●
16	R2	24	140	16	48	15.2	●
16	R3	24	140	16	48	15.2	●
20	R0.5	30	160	20	60	19	●
20	R1	30	160	20	60	19	●
20	R2	30	160	20	60	19	●
20	R3	30	160	20	60	19	●

Feature of product:

High Performance End Mills with
Corner Radius- Short Type · Long
Length

Using SMG carbide material and
coated multilayer nano coating
to increase lubrication and wear
resistance with good tool life.

High precision corner radius
suitable for general & finishing on
high hardness and high precision
mold process.

Side Milling

Work Material		GR.1/GR.2 /GR.3 Carbon Steel/Low-alloyed Steel/Hi-alloyed Steel (~24HRC) (~30HRC)		GR.4 /GR.5 Hardened Steel/Hardened Steel (30~38HRC) (38~48HRC)		GR.6 Hardened Steel (48~56HRC)		GR.7 Hardened Steel (56~68HRC)		GR.8 Stainless Steel		GR.9 Cast Iron	
Vc m/min		150		130		100		50		60		150	
Code No.	(Dc)	RPM (min-1)	Feed (mm/min)	RPM (min-1)	Feed (mm/min)	RPM (min-1)	Feed (mm/min)	RPM (min-1)	Feed (mm/min)	RPM (min-1)	Feed (mm/min)	RPM (min-1)	Feed (mm/min)
B277TX-6	6	7963	1593	7,200	1,080	5,300	820	2,200	175	3185	637	8,000	1,200
B277TX-8	8	5972	1433	5,400	990	4,000	750	1,650	185	2389	573	6,000	1,100
B277TX-10	10	4778	1338	4,320	990	3,200	745	1,300	165	1911	535	4,800	1,100
B277TX-12	12	3981	1274	3,600	959	2,700	740	1,100	145	1593	510	4,000	1,065
B277TX-16	16	2986	1075	2,700	900	2,000	730	840	170	1194	430	3,000	1,000
B277TX-20	20	2389	956	2,160	860	1,600	700	670	170	956	382	2,400	955
	ap:1.0D		ap:1.0D		ap:1.0D		ap:1.0D		ap:1.0D		ap:1.0D		
	ae:0.05D		ae:0.05D		ae:0.03D		ae:0.02D		ae:0.03D		ae:0.05D		

High Speed Side Milling

Work Material		GR.1/GR.2 /GR.3 Carbon Steel/Low-alloyed Steel/Hi-alloyed Steel (~24HRC) (~30HRC)		GR.4 /GR.5 Hardened Steel/Hardened Steel (30~38HRC) (38~48HRC)		GR.6 Hardened Steel (48~56HRC)		GR.7 Hardened Steel (56~68HRC)		GR.8 Stainless Steel		GR.9 Cast Iron	
Vc m/min		200		180		150		100		100		200	
Code No.	(Dc)	RPM (min-1)	Feed (mm/min)	RPM (min-1)	Feed (mm/min)	RPM (min-1)	Feed (mm/min)	RPM (min-1)	Feed (mm/min)	RPM (min-1)	Feed (mm/min)	RPM (min-1)	Feed (mm/min)
B277TX-6	6	10617	2123	9554	1080	7963	700	5308	530	5308	1062	10617	1200
B277TX-8	8	7963	1911	7166	1080	5972	700	3981	530	3981	956	7963	1200
B277TX-10	10	6370	1784	5733	765	4778	630	3185	420	3185	892	6370	850
B277TX-12	12	5308	1699	4777	765	3981	630	2654	420	2654	849	5308	850
B277TX-16	16	3981	1433	3583	810	2986	650	1991	420	1991	717	3981	900
B277TX-20	20	3185	1274	2867	810	2389	650	1593	420	1593	637	3185	900
	ap:1.0D		ap:1.0D		ap:1.0D		ap:1.0D		ap:1.0D		ap:1.0D		
	ae:0.01D		ae:0.01D		ae:0.01D		ae:0.01D		ae:0.01D		ae:0.03D		ae:0.01D

※ Notice: B277TX is Long Length series End Mills. Please adjust the parameter according

1. Please work with good rigidity / high precision facilities and collet chuck.
2. Please choose proper cutting fluid.
3. The cutting data is reference value only. Please adjust it according to your real working conditions.
4. If RPM is lower the reference value, the Feed rate (fz) and RPM should be reduced by the same proportion.
5. If vibration occurs during cutting, please reduce cutting parameter.

B259TX / B269TX

Finishing End Mills With Corner Radius

SMG
Carbide

AlTiSiN
TX



Type of Operation



Work Material

P	H	M	K	N	S
	●		○		

H <48HRC
Hardened Steel

H <56HRC
Hardened Steel

H <68HRC
Hardened Steel

K Cast Iron

Feature of product:

Finishing End Mills with Corner Radius- 6 Flutes - Standard & Long Length

Widely used in roughing and finishing 3D curved profile.

Good wear resistance and lubricating effect with Nano multilayer coating.

Designed with 6 flutes to have high central hardness.

Suitable for steel materials with high hardness.

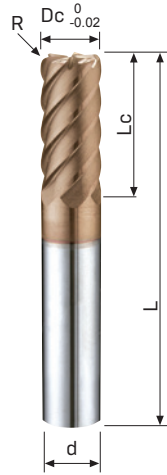

Code No. B259TX-Dc×R

Dc 0 -0.02	R	Lc mm	L mm	d h6	AlTiSiN B259TX
6	R0.5	16	50	6	●
6	R1	16	50	6	●
8	R0.5	20	60	8	●
8	R1	20	60	8	●
10	R0.5	22	72	10	●
10	R1	22	72	10	●
12	R0.5	26	75	12	●
12	R1	26	75	12	●
16	R1	38	100	16	●
16	R2	38	100	16	●
20	R1	38	100	20	●
20	R2	38	100	20	●

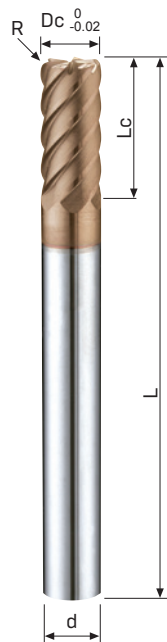

Code No. B269TX-Dc×R

Dc 0 -0.02	R	Lc mm	L mm	d h6	AlTiSiN B269TX
6	R0.5	16	80	6	●
6	R1	16	80	6	●
8	R0.5	20	100	8	●
8	R1	20	100	8	●
10	R0.5	22	100	10	●
10	R1	22	100	10	●
12	R0.5	26	110	12	●
12	R1	26	110	12	●
16	R1	38	140	16	●
16	R2	38	140	16	●
20	R1	38	160	20	●
20	R2	38	160	20	●

High feed cutting

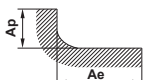
Work Material		GR.5 Hardened Steel (38-48HRC)		GR.6 Hardened Steel (48-56HRC)		GR.7 Hardened Steel (56-68HRC)		GR.9 Cast Iron	
Vc m/min		200		180		160		200	
Code No.	Dc	RPM (min-1)	Feed (mm/min)	RPM (min-1)	Feed (mm/min)	RPM (min-1)	Feed (mm/min)	RPM (min-1)	Feed (mm/min)
B259TX/B269TX	6	10,617	2,548	9,555	2,293	8,493	2,038	10,617	2,548
B259TX/B269TX	8	7,963	2,389	7,166	2,150	6,370	2,293	7,963	2,389
B259TX/B269TX	10	6,370	3,058	5,733	2,752	5,096	2,446	6,370	3,058
B259TX/B269TX	12	5,308	3,185	4,778	2,867	4,247	2,548	5,308	3,185
B259TX/B269TX	16	3,981	2,867	3,583	2,580	3,185	2,293	3,981	2,867
B259TX/B269TX	20	3,185	2,293	2,867	2,064	2,548	1,835	3,185	2,293
 (mm)		ap:0.2×R		ap:0.2×R		ap:0.1×R		ap:0.2×R	
		ae:0.5D		ae:0.5D		ae:0.5D		ae:0.5D	

Side Milling

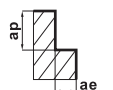
Work Material		GR.5 Hardened Steel (38-48HRC)		GR.6 Hardened Steel (48-56HRC)		GR.7 Hardened Steel (56-68HRC)		GR.9 Cast Iron	
Vc m/min		150		100		90		145	
Code No.	Dc	RPM (min-1)	Feed (mm/min)	RPM (min-1)	Feed (mm/min)	RPM (min-1)	Feed (mm/min)	RPM (min-1)	Feed (mm/min)
B259TX/B269TX-6	6	6,600	2,300	5,300	1,800	4,000	1,000	7,400	2,600
B259TX/B269TX-8	8	4,900	2,350	4,000	1,850	3,000	1,000	5,500	2,600
B259TX/B269TX-10	10	4,000	2,400	3,200	1,900	2,400	1,000	4,500	2,600
B259TX/B269TX-12	12	3,300	2,400	2,600	1,900	2,000	1,000	3,700	2,600
B259TX/B269TX-16	16	2,500	2,100	2,000	1,700	1,500	900	2,800	2,400
B259TX/B269TX-20	20	2,000	1,900	1,600	1,400	1,200	830	2,300	2,100
 (mm)		ap:1.5D		ap:1.5D		ap:1.5D		ap:1.6D	
		ae:0.1D		ae:0.05D		ae:0.03D		ae:0.1D	

※ Notice: B269TX is Long Length series End Mills. Please adjust the parameter according

1. Please work with good rigidity / high precision facilities and collet chuck.
2. Please choose proper cutting fluid.
3. The cutting data is reference value only. Please adjust it according to your real working conditions.
4. If RPM is lower the reference value, the Feed rate (fz) and RPM should be reduced by the same proportion.
5. If vibration occurs during cutting, please reduce cutting parameter.

B271TX

High Performance End Mills With Corner Radius

Code No. B271TX-Dc×R

SMG
CarbideAlTiSiN
TX

Type of Operation



Work Material

P	H	M	K	N	S
	●		●		

H	<48HRC Hardened Steel
---	--------------------------

H	<56HRC Hardened Steel
---	--------------------------

H	<68HRC Hardened Steel
---	--------------------------

K	Cast Iron
---	-----------

Feature of product:

Stepped High Performance End Mills with Corner Radius

With SMG carbide material and Nano multilayer coating, wear resistance and lubrication effect are highly enhanced to have better tool life.

High precision R value and strong short cutting length.

Suitable for working high hardness materials and high precision mold in layer machining.

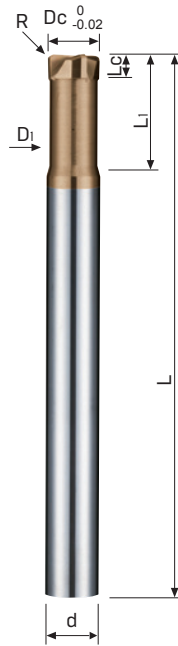

Dc 0 -0.02	R ±0.01	Lc mm	L mm	d h6	L1 mm	D1 mm	AlTiSiN B271TX
3	R0.75	1.2	70	6	7.5	2.7	●
4	R1	1.6	70	6	10	3.6	●
5	R1	2	80	6	12	4.5	●
5	R1.2	2	80	6	12	4.5	●
6	R1	2.5	80	6	12	5.4	●
6	R1.5	2.5	80	6	12	5.4	●
8	R1	3.5	100	8	16	7.2	●
8	R2	3.5	100	8	16	7.2	●
10	R1	4	100	10	20	9	●
10	R2	4	100	10	20	9	●
12	R1	5	110	12	24	11	●
12	R2	5	110	12	24	11	●
12	R3	5	110	12	24	11	●

High feed cutting

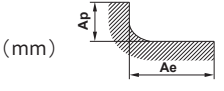
Work Material		GR.5 Hardened Steel (38-48HRC)		GR.6 Hardened Steel (48-56HRC)		GR.7 Hardened Steel (56-68HRC)		GR.9 Cast Iron	
Vc m/min		70		50		30		100	
Code No.	Dc	RPM (min-1)	Feed (mm/min)	RPM (min-1)	Feed (mm/min)	RPM (min-1)	Feed (mm/min)	RPM (min-1)	Feed (mm/min)
B271TX-3	3	7,400	3,800	5,300	2,500	3,200	990	10,500	6,000
B271TX-4	4	5,500	4,100	4,000	2,700	2,400	1,000	8,000	6,500
B271TX-5	5	4,450	4,300	3,200	2,800	1,900	1,100	6,350	6,800
B271TX-6	6	3,700	4,300	2,600	2,800	1,600	1,100	5,300	6,800
B271TX-8	8	2,800	4,300	2,000	2,800	1,200	1,100	4,000	7,000
B271TX-10	10	2,250	4,400	1,600	2,800	1,000	1,100	3,200	7,000
B271TX-12	12	1,850	4,400	1,350	2,800	800	1,100	2,650	7,000
		ap:0.2xR		ap:0.2xR		ap:0.1xR		ap:0.2xR	
		ae:0.5D		ae:0.5D		ae:0.5D		ae:0.5D	

1. Please work with good rigidity / high precision facilities and collet chuck.
2. Please choose proper cutting fluid.
3. The cutting data is reference value only. Please adjust it according to your real working conditions.
4. If RPM is lower the reference value, the Feed rate [fz] and RPM should be reduced by the same proportion.
5. If vibration occurs during cutting, please reduce cutting parameter.

E105X

Taper End Mills

Code No. E105X-Dc×β

UMG
CarbideAlTiN
X-NaNo

Type of Operation

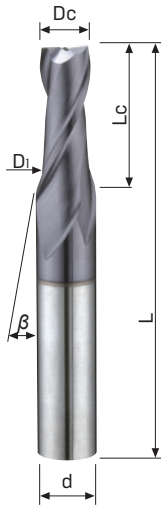

Dc	β	D1	Lc	L	d	AlTiN E105X	Dc	β	D1	Lc	L	d	AlTiN E105X
mm	on Side	mm	mm	mm	h6		mm	on Side	mm	mm	mm	h6	
1	30'	1.07	4	50	4	●	4	30'	4.26	15	50	6	●
1	1°	1.14	4	50	4	●	4	1°	4.52	15	50	6	●
1	1°30'	1.21	4	50	4	●	4	1°30'	4.79	15	50	6	●
1	2°	1.28	4	50	4	●	4	2°	5.04	15	50	6	●
1	2°30'	1.35	4	50	4	●	4	2°30'	5.31	15	50	6	●
1	3°	1.42	4	50	4	●	4	3°	5.57	15	50	6	●
1	4°	1.56	4	50	4	●	4	4°	6.1	15	60	8	●
1	5°	1.7	4	50	4	●	4	5°	6.62	15	60	8	●
1	6°	1.84	4	50	4	●	4	6°	7.15	15	60	8	●
1	7°	1.98	4	50	4	●	4	7°	7.68	15	60	8	●
1	10°	2.41	4	50	4	●	4	10°	9.3	15	70	10	●
1.5	30'	1.59	5	50	4	●	5	30'	5.34	20	60	6	●
1.5	1°	1.67	5	50	4	●	5	1°	5.7	20	60	6	●
1.5	1°30'	1.76	5	50	4	●	5	1°30'	6	20	60	6	●
1.5	2°	1.85	5	50	4	●	5	2°	6.39	20	60	8	●
1.5	2°30'	1.93	5	50	4	●	5	2°30'	6.75	20	60	8	●
1.5	3°	2.02	5	50	4	●	5	3°	7.1	20	60	8	●
1.5	4°	2.2	5	50	4	●	5	4°	7.8	20	60	8	●
1.5	5°	2.37	5	50	4	●	5	5°	8.5	20	70	10	●
1.5	6°	2.55	5	50	4	●	5	6°	9.2	20	70	10	●
1.5	7°	2.73	5	50	4	●	5	7°	9.91	20	70	10	●
1.5	10°	3.26	5	50	4	●	5	10°	12	20	75	12	●
2	30'	2.1	6	50	4	●	6	30'	6.35	20	60	8	●
2	1°	2.21	6	50	4	●	6	1°	6.7	20	60	8	●
2	1°30'	2.31	6	50	4	●	6	1°30'	7.05	20	60	8	●
2	2°	2.41	6	50	4	●	6	2°	7.4	20	60	8	●
2	2°30'	2.52	6	50	4	●	6	2°30'	7.75	20	60	8	●
2	3°	2.62	6	50	4	●	6	3°	8	20	60	8	●
2	4°	2.84	6	50	4	●	6	4°	8.8	20	70	10	●
2	5°	3.05	6	50	4	●	6	5°	9.5	20	70	10	●
2	6°	3.26	6	50	4	●	6	6°	10.2	20	75	12	●
2	7°	3.47	6	50	4	●	6	7°	10.91	20	75	12	●
2	10°	4.11	6	50	6	●	6	10°	13.05	20	75	12	●
2.5	30'	2.64	8	50	4	●	8	30'	8.44	25	70	10	●
2.5	1°	2.78	8	50	4	●	8	1°	8.87	25	70	10	●
2.5	1°30'	2.91	8	50	4	●	8	1°30'	9.31	25	70	10	●
2.5	2°	3.05	8	50	4	●	8	2°	9.74	25	70	10	●
2.5	2°30'	3.2	8	50	4	●	8	2°30'	10	25	70	10	●
2.5	3°	3.33	8	50	4	●	8	3°	10.62	25	75	12	●
2.5	4°	3.62	8	50	4	●	8	4°	12.37	25	90	12	●
2.5	5°	3.9	8	50	4	●	10	30'	10.61	35	90	10	●
2.5	6°	4.18	8	50	6	●	10	1°	11.22	35	90	10	●
2.5	7°	4.46	8	50	6	●	10	1°30'	11.83	35	90	10	●
2.5	10°	5.32	8	50	6	●	10	2°	12.44	35	90	12	●
3	30'	3.17	10	50	6	●	10	2°30'	13.06	35	90	12	●
3	1°	3.35	10	50	6	●	10	3°	13.67	35	90	12	●
3	1°30'	3.52	10	50	6	●	10	5°	16	35	100	16	●
3	2°	3.69	10	50	6	●							
3	2°30'	3.87	10	50	6	●							
3	3°	4.05	10	50	6	●							
3	4°	4.4	10	50	6	●							
3	5°	4.75	10	50	6	●							
3	6°	5.1	10	50	6	●							
3	7°	5.46	10	50	6	●							
3	10°	6.53	10	60	8	●							

Work Material

P	H	M	K	N	S
●	●	●	○	○	○

P	Steel
---	-------

H	<38HRC Hardened Steel
---	--------------------------

H	<48HRC Hardened Steel
---	--------------------------

H	<56HRC Hardened Steel
---	--------------------------

K	Cast Iron
---	-----------

N	Aluminium
---	-----------

N	Copper
---	--------

Feature of product:

Taper End Mills

With UMG carbide material and Nano multilayer coating, wear resistance and lubrication effect are highly enhanced to have better tool life.

Available in complete spec in various angle.

Suitable in tapered milling process for various mold.



















Side Milling

Work Material		GR.1 Carbon Steel		GR.2 Low-alloyed Steel (~24HRC)		GR.3 Hi-alloyed Steel (~30HRC)		GR.4 Hardened Steel (30~38HRC)		GR.5 Hardened Steel (38~48HRC)		GR.6 Hardened Steel (48~56HRC)	
Vc m/min		60		60		60		45		40		35	
Code No.	Dc	RPM (min-1)	Feed (mm/min)	RPM (min-1)	Feed (mm/min)	RPM (min-1)	Feed (mm/min)	RPM (min-1)	Feed (mm/min)	RPM (min-1)	Feed (mm/min)	RPM (min-1)	Feed (mm/min)
E105X-1	1	15,500	120	15,500	120	15,500	120	13,000	85	12,000	80	10,500	35
E105X-1.5	1.5	10,500	120	10,500	120	10,500	120	9,000	85	8,200	80	7,000	35
E105X-2	2	7,900	145	7,900	145	7,900	120	6,600	85	6,300	80	5,200	35
E105X-2.5	2.5	6,200	140	6,200	140	6,200	115	5,300	85	4,900	80	4,200	35
E105X-3	3	5,100	140	5,100	140	5,100	120	4,400	80	4,000	80	3,500	35
E105X-4	4	3,800	140	3,800	140	3,800	115	3,400	80	3,000	80	2,500	35
E105X-5	5	3,100	140	3,100	140	3,100	115	2,600	80	2,400	75	2,000	35
E105X-6	6	2,600	140	2,600	140	2,600	115	2,200	80	2,000	75	1,700	35
E105X-8	8	1,900	140	1,900	140	1,900	115	1,600	80	1,500	75	1,300	35
E105X-10	10	1,500	140	1,500	140	1,500	110	1,300	80	1,200	75	1,000	35
(mm)		ap:2.5		ap:2.5		ap:2.5		ap:2.5		ap:2.5		ap:2.5	
		ae:0.02		ae:0.02		ae:0.02		ae:0.02		ae:0.02		ae:0.02	

1. Please work with good rigidity / high precision facilities and collet chuck.
2. Please choose proper cutting fluid.
3. The cutting data is reference value only. Please adjust it according to your real working conditions.
4. If RPM is lower the reference value, the Feed rate (fz) and RPM should be reduced by the same proportion.
5. If vibration occurs during cutting, please reduce cutting parameter.

End Mills For Rib Processing



Page	151	153	155	159	161	163
Apperance						
Code No	F692TX	F694TX	F690TX	F693TX	F695TX	F691TX
Carbide	SMG Carbide	SMG Carbide	SMG Carbide	SMG Carbide	SMG Carbide	SMG Carbide
Coating	AlTiSiN TX	AlTiSiN TX	AlTiSiN TX	AlTiSiN TX	AlTiSiN TX	AlTiSiN TX
Helix Angle	 30°	 30°	 30°	 30°	 30°	 30°
No.of Flutes	 2	 4	 2	 4	 2	 2

ASIA

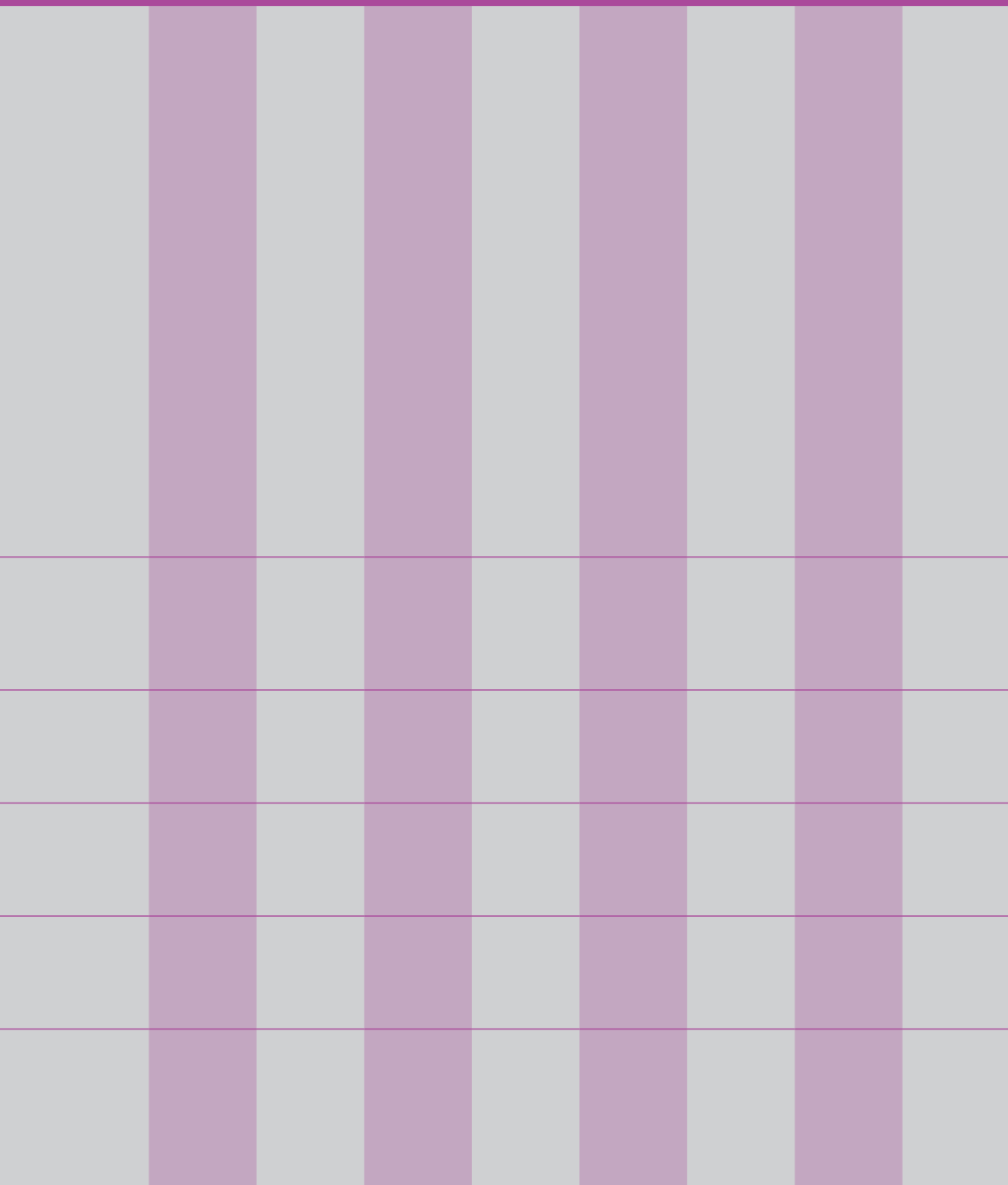

F692TX

End Mills For Rib Processing

Code No. F692TX-Dc×L1

SMG Carbide

AlTiSiN TX



Type of Operation



Dc	L1	Lc	L	d	D1	AlTiSiN	Dc	L1	Lc	L	d	D1	AlTiSiN
0-0.02	mm	mm	mm	h5	mm	F692TX	0-0.02	mm	mm	mm	h5	mm	F692TX
0.2	0.5	0.3	50	4	0.17	●	1.5	10	2.3	50	4	1.45	●
0.2	1	0.3	50	4	0.17	●	1.5	12	2.3	50	4	1.45	●
0.2	2	0.3	50	4	0.17	●	1.5	14	2.3	50	4	1.45	●
0.2	3	0.3	50	4	0.17	●	1.5	16	2.3	50	4	1.45	●
0.3	1	0.45	50	4	0.27	●	1.5	18	2.3	60	4	1.45	●
0.3	1.5	0.45	50	4	0.27	●	1.5	20	2.3	60	4	1.45	●
0.3	2	0.45	50	4	0.27	●	1.5	25	2.3	65	4	1.45	●
0.3	3	0.45	50	4	0.27	●	1.5	30	2.3	70	4	1.45	●
0.3	4	0.45	50	4	0.27	●	1.6	6	2.4	50	4	1.55	●
0.4	1	0.6	50	4	0.37	●	1.6	8	2.4	50	4	1.55	●
0.4	1.5	0.6	50	4	0.37	●	1.6	10	2.4	50	4	1.55	●
0.4	2	0.6	50	4	0.37	●	1.6	12	2.4	50	4	1.55	●
0.4	3	0.6	50	4	0.37	●	1.6	14	2.4	50	4	1.55	●
0.4	4	0.6	50	4	0.37	●	1.6	16	2.4	50	4	1.55	●
0.4	5	0.6	50	4	0.37	●	1.6	18	2.4	60	4	1.55	●
0.4	6	0.6	50	4	0.37	●	1.6	20	2.4	60	4	1.55	●
0.4	8	0.6	50	4	0.37	●	1.8	6	2.7	50	4	1.75	●
0.5	1	0.7	50	4	0.45	●	1.8	8	2.7	50	4	1.75	●
0.5	2	0.7	50	4	0.45	●	1.8	10	2.7	50	4	1.75	●
0.5	3	0.7	50	4	0.45	●	1.8	12	2.7	50	4	1.75	●
0.5	4	0.7	50	4	0.45	●	1.8	14	2.7	50	4	1.75	●
0.5	6	0.7	50	4	0.45	●	1.8	16	2.7	50	4	1.75	●
0.5	8	0.7	50	4	0.45	●	1.8	18	2.7	60	4	1.75	●
0.5	10	0.7	50	4	0.45	●	1.8	20	2.7	60	4	1.75	●
0.6	2	0.9	50	4	0.55	●	2	4	3	50	4	1.95	●
0.6	3	0.9	50	4	0.55	●	2	6	3	50	4	1.95	●
0.6	4	0.9	50	4	0.55	●	2	8	3	50	4	1.95	●
0.6	6	0.9	50	4	0.55	●	2	10	3	50	4	1.95	●
0.6	8	0.9	50	4	0.55	●	2	12	3	50	4	1.95	●
0.6	10	0.9	50	4	0.55	●	2	14	3	50	4	1.95	●
0.7	2	1	50	4	0.65	●	2	16	3	50	4	1.95	●
0.7	4	1	50	4	0.65	●	2	18	3	60	4	1.95	●
0.7	6	1	50	4	0.65	●	2	20	3	60	4	1.95	●
0.7	8	1	50	4	0.65	●	2	25	3	60	4	1.95	●
0.8	2	1.2	50	4	0.75	●	2	30	3	70	4	1.95	●
0.8	4	1.2	50	4	0.75	●	2	35	3	75	4	1.95	●
0.8	6	1.2	50	4	0.75	●	2	40	3	80	4	1.95	●
0.8	8	1.2	50	4	0.75	●	2.5	8	3.7	50	4	2.4	●
0.8	10	1.2	50	4	0.75	●	2.5	10	3.7	50	4	2.4	●
0.8	12	1.2	50	4	0.75	●	2.5	12	3.7	50	4	2.4	●
0.9	4	1.4	50	4	0.85	●	2.5	14	3.7	50	4	2.4	●
0.9	6	1.4	50	4	0.85	●	2.5	16	3.7	60	4	2.4	●
0.9	8	1.4	50	4	0.85	●	2.5	18	3.7	60	4	2.4	●
0.9	10	1.4	50	4	0.85	●	2.5	20	3.7	60	4	2.4	●
1	2	1.5	50	4	0.95	●	2.5	25	3.7	70	4	2.4	●
1	3	1.5	50	4	0.95	●	2.5	30	3.7	70	4	2.4	●
1	4	1.5	50	4	0.95	●	2.5	40	3.7	80	4	2.4	●
1	6	1.5	50	4	0.95	●	3	8	4.5	50	6	2.85	●
1	8	1.5	50	4	0.95	●	3	10	4.5	50	6	2.85	●
1	10	1.5	50	4	0.95	●	3	12	4.5	50	6	2.85	●
1	12	1.5	50	4	0.95	●	3	14	4.5	60	6	2.85	●
1	14	1.5	50	4	0.95	●	3	16	4.5	60	6	2.85	●
1	16	1.5	50	4	0.95	●	3	18	4.5	60	6	2.85	●
1	18	1.5	60	4	0.95	●	3	20	4.5	60	6	2.85	●
1	20	1.5	60	4	0.95	●	3	25	4.5	70	6	2.85	●
1.2	6	1.8	50	4	1.15	●	3	30	4.5	70	6	2.85	●
1.2	8	1.8	50	4	1.15	●	3	35	4.5	80	6	2.85	●
1.2	10	1.8	50	4	1.15	●	3	40	4.5	90	6	2.85	●
1.2	12	1.8	50	4	1.15	●	3	50	4.5	100	6	2.85	●
1.2	14	1.8	50	4	1.15	●	4	12	6	60	6	3.85	●
1.2	16	1.8	50	4	1.15	●	4	16	6	60	6	3.85	●
1.4	6	2.1	50	4	1.35	●	4	20	6	70	6	3.85	●
1.4	8	2.1	50	4	1.35	●	4	25	6	70	6	3.85	●
1.4	10	2.1	50	4	1.35	●	4	30	6	80	6	3.85	●
1.4	12	2.1	50	4	1.35	●	4	35	6	80	6	3.85	●
1.4	14	2.1	50	4	1.35	●	4	40	6	90	6	3.85	●
1.4	16	2.1	50	4	1.35	●	4	45	6	100	6	3.85	●
1.5	4	2.3	50	4	1.45	●	4	50	6	100	6	3.85	●
1.5	6	2.3	50	4	1.45	●							
1.5	8	2.3	50	4	1.45	●							

Feature of product:

End Mills For Rib Processing- 2 Flutes Square

Widely used in high precision mold and deep machining angle clean with long neck.

Good wear resistance and lubricating effect with Nano multilayer coating.

Available with complete size range.

Workable for various steel materials and copper electrode materials.

Slotting

Code No.	Work Material	GR.1 / GR.2 / GR.3 Carbon Steel / Low-alloyed Steel / Hi-alloyed Steel (-24HRC) (-30HRC)			GR.4 / GR.5 Hardened Steel / Hardened Steel (30-38HRC) (38-48HRC)			GR.6 Hardened Steel (48-56HRC)			GR.7 Hardened Steel (56-68HRC)		
		RPM (min-1)	Feed (mm/min)	ap (mm)	RPM (min-1)	Feed (mm/min)	ap (mm)	RPM (min-1)	Feed (mm/min)	ap (mm)	RPM (min-1)	Feed (mm/min)	ap (mm)
F692TX	0.2×0.5	50,000	320	0.009	50,000	170	0.006	50,000	150	0.004	50,000	10	0.003
F692TX	0.2×1	50,000	320	0.008	50,000	150	0.005	50,000	150	0.004	50,000	10	0.003
F692TX	0.2×2	50,000	290	0.006	50,000	130	0.004	50,000	120	0.003	50,000	10	0.002
F692TX	0.2×3	50,000	280	0.002	50,000	100	0.001	50,000	100	0.001	50,000	10	0.001
F692TX	0.3×1	48,000	448	0.009	48,000	352	0.006	41,680	264	0.004	14,600	14	0.003
F692TX	0.3×1.5	40,640	368	0.008	40,640	288	0.005	34,160	208	0.004	14,600	13	0.003
F692TX	0.3×2	33,200	280	0.006	33,200	224	0.004	26,560	152	0.003	14,600	12	0.002
F692TX	0.3×3	25,520	192	0.002	25,520	152	0.001	20,400	104	0.001	14,600	10	0.001
F692TX	0.3×4	20,960	136	0.001	20,960	112	0.001	16,720	80	0.001	14,600	9	0.001
F692TX	0.4×1	42,160	528	0.011	38,480	376	0.007	30,800	256	0.004	14,300	17	0.003
F692TX	0.4×1.5	42,160	528	0.011	38,480	376	0.007	30,800	256	0.004	14,300	17	0.003
F692TX	0.4×2	40,000	488	0.009	35,680	344	0.006	28,560	232	0.004	14,600	17	0.003
F692TX	0.4×3	35,600	408	0.005	30,000	272	0.004	24,000	184	0.003	14,300	16	0.002
F692TX	0.4×4	32,800	352	0.004	26,480	224	0.003	21,200	152	0.002	14,300	15	0.001
F692TX	0.4×5	30,800	304	0.003	24,080	192	0.002	19,280	128	0.001	14,300	14	0.001
F692TX	0.4×6	30,800	280	0.002	24,000	180	0.001	18,000	100	0.001	14,000	10	0.001
F692TX	0.4×8	30,800	250	0.002	24,000	160	0.001	17,000	80	0.001	14,000	10	0.001
F692TX	0.5×1	45,440	720	0.015	32,480	408	0.011	26,000	280	0.008	14,000	20	0.004
F692TX	0.5×2	45,440	720	0.015	32,480	408	0.011	26,000	280	0.008	14,000	20	0.004
F692TX	0.5×3	35,360	528	0.007	25,760	296	0.007	20,560	208	0.005	14,000	19	0.004
F692TX	0.5×4	32,480	464	0.008	23,760	264	0.006	18,960	184	0.004	14,000	18	0.003
F692TX	0.5×6	26,720	336	0.004	19,760	200	0.003	15,760	136	0.002	14,000	16	0.001
F692TX	0.5×8	23,280	256	0.002	17,280	152	0.001	13,840	104	0.001	14,000	14	0.001
F692TX	0.5×10	20,880	200	0.001	15,680	120	0.001	12,480	80	0.001	14,000	12	0.001
F692TX	0.6×2/0.6×3/0.6×4	50,880	992	0.023	31,280	480	0.016	25,040	328	0.011	12,000	23	0.006
F692TX	0.6×6	25,680	416	0.007	18,400	232	0.005	14,720	160	0.003	12,000	19	0.002
F692TX	0.6×8	21,440	312	0.004	16,000	184	0.003	12,800	128	0.002	12,000	17	0.001
F692TX	0.6×10	18,720	240	0.002	14,320	144	0.002	11,440	104	0.001	12,000	15	0.001
F692TX	0.8×4/0.8×6	29,680	744	0.027	19,280	384	0.019	15,440	264	0.013	8,000	20	0.01
F692TX	0.8×8	19,280	416	0.009	13,760	240	0.006	11,040	160	0.004	8,000	16	0.003
F692TX	0.8×10	16,800	336	0.006	13,760	240	0.006	11,040	160	0.004	8,000	14	0.002
F692TX	0.8×12	14,960	272	0.004	11,280	160	0.003	9,040	112	0.002	8,000	12	0.001
F692TX	1×2 / 1×3 / 1×4	27,280	936	0.04	17,200	464	0.028	13,760	320	0.02	6,500	15	0.01
F692TX	1×6	21,200	680	0.023	14,080	352	0.016	11,280	248	0.012	6,500	14	0.006
F692TX	1×10	15,360	424	0.01	11,040	240	0.007	8,800	168	0.005	6,500	12	0.003
F692TX	1×12	13,760	352	0.007	10,080	200	0.005	8,080	136	0.003	6,500	11	0.002
F692TX	1×16	11,440	240	0.004	8,800	144	0.003	7,040	104	0.002	6,500	10	0.001
F692TX	1×20	10,000	160	0.003	8,800	144	0.003	7,040	104	0.002	6,500	10	0.001
F692TX	1.5×4/1.5×6/1.5×8	18,240	896	0.057	11,520	440	0.04	9,200	304	0.028	9,600	60	0.016
F692TX	1.5×10	13,280	600	0.03	8,960	312	0.021	7,120	216	0.015	9,600	13	0.009
F692TX	1.5×16	10,300	400	0.016	7,300	210	0.011	5,800	150	0.008	9,600	1	0.003
F692TX	1.5×20	9,500	330	0.011	6,600	170	0.007	5,200	130	0.005	9,600	10	0.003
F692TX	1.5×25	9,200	320	0.009	6,400	160	0.008	4,900	120	0.008	9,600	10	0.002
F692TX	1.5×30	9,000	300	0.007	6,200	140	0.006	4,600	110	0.006	9,600	10	0.001
F692TX	2×4 / 2×6 / 2×8	7,500	300	0.064	5,200	150	0.045	4,000	100	0.032	9,600	230	0.019
F692TX	2×10	11,840	736	0.045	7,760	376	0.031	6,240	264	0.022	9,600	45	0.013
F692TX	2×14	9,600	560	0.031	6,560	296	0.022	5,280	208	0.016	9,600	16	0.009
F692TX	2×20	7,680	400	0.018	5,520	224	0.013	4,400	152	0.009	9,600	11	0.002
F692TX	2×30	6,000	248	0.008	4,480	144	0.005	3,600	104	0.004	9,600	11	0.001
F692TX	2×40	5,000	200	0.003	3,800	90	0.001	3,000	40	0.001	9,600	10	0.001
F692TX	2.5×8/2.5×10/2.5×12	12,000	1,072	0.077	7,680	536	0.054	6,160	368	0.039	9,600	227	0.023
F692TX	2.5×14	8,560	704	0.052	5,840	376	0.036	4,640	256	0.026	9,600	42	0.015
F692TX	2.5×20	6,960	520	0.033	4,880	288	0.023	3,920	200	0.017	9,600	14	0.01
F692TX	2.5×25	6,080	416	0.022	4,400	240	0.015	3,520	168	0.011	9,600	10	0.008
F692TX	2.5×30	5,440	344	0.014	4,000	200	0.01	3,200	136	0.007	9,600	10	0.005
F692TX	2.5×40	5,300	300	0.01	3,500	160	0.006	2,800	100	0.004	9,600	10	0.003
F692TX	3×8 / 3×10 / 3×12	10,560	1,176	0.103	6,400	560	0.072	5,120	384	0.052	8,000	435	0.031
F692TX	3×14	7,680	800	0.072	4,960	408	0.051	4,000	280	0.036	8,000	81	0.021
F692TX	3×20	6,240	600	0.05	4,240	320	0.035	3,440	224	0.025	8,000	27	0.015
F692TX	3×30	4,960	416	0.026	3,600	232	0.018	2,880	160	0.013	8,000	10	0.007
F692TX	3×40	4,400	340	0.013	3,100	180	0.009	2,400	110	0.005	8,000	10	0.003
F692TX	3×50	4,200	320	0.009	2,900	160	0.005	2,200	90	0.003	8,000	10	0.001
F692TX	4×12 / 4×16 / 4×20	6,800	1,024	0.112	4,080	480	0.078	3,280	328	0.056	6,000	388	0.033
F692TX	4×30	4,000	504	0.048	2,640	264	0.033	2,080	184	0.024	6,000	24	0.014
F692TX	4×40	3,360	376	0.03	2,320	200	0.021	1,840	144	0.015	6,000	10	0.009
F692TX	4×50	2,960	288	0.018	2,080	160	0.013	1,680	112	0.009	6,000	10	0.001



F694TX

End Mills For Rib Processing

Code No. F694TX-Dc×L1

SMG
Carbide

AlTiSiN
TX



Type of Operation



Work Material

P	H	M	K	N	S
●	●	●	○	○	○

P Steel

H <38HRC
Hardened Steel

H <48HRC
Hardened Steel

H <56HRC
Hardened Steel

H <68HRC
Hardened Steel

K Cast Iron

N Copper

Feature of product:

End Mills For Rib Processing- 4
Flutes Square

Widely used in high precision mold
and deep machining angle clean
with long neck.

Good wear resistance and
lubricating effect with Nano
multilayer coating.

Workable for various steel
materials and copper electrode
materials.



Dc 0 -0.02	L1 mm	Lc mm	L mm	d h5	D1 mm	AlTiSiN F694TX
1	3	1.5	50	4	0.95	●
1	4	1.5	50	4	0.95	●
1	6	1.5	50	4	0.95	●
1	8	1.5	50	4	0.95	●
1	10	1.5	50	4	0.95	●
1	12	1.5	50	4	0.95	●
1.5	4	2.3	50	4	1.45	●
1.5	6	2.3	50	4	1.45	●
1.5	8	2.3	50	4	1.45	●
1.5	10	2.3	50	4	1.45	●
1.5	12	2.3	50	4	1.45	●
1.5	16	2.3	50	4	1.45	●
2	6	3	50	4	1.95	●
2	8	3	50	4	1.95	●
2	10	3	50	4	1.95	●
2	12	3	50	4	1.95	●
2	16	3	50	4	1.95	●
2	20	3	60	4	1.95	●
2	25	3	60	4	1.95	●
2	30	3	70	4	1.95	●
3	8	4.5	50	6	2.85	●
3	10	4.5	50	6	2.85	●
3	12	4.5	50	6	2.85	●
3	16	4.5	60	6	2.85	●
3	20	4.5	60	6	2.85	●
3	25	4.5	70	6	2.85	●
3	30	4.5	70	6	2.85	●
4	12	6	60	6	3.85	●
4	16	6	60	6	3.85	●
4	20	6	70	6	3.85	●
4	25	6	70	6	3.85	●
4	30	6	80	6	3.85	●
4	40	6	90	6	3.85	●
5	16	7.5	60	6	4.85	●
5	20	7.5	70	6	4.85	●
5	30	7.5	80	6	4.85	●
5	40	7.5	90	6	4.85	●
6	20	9	70	6	5.85	●
6	30	9	80	6	5.85	●
6	40	9	90	6	5.85	●
6	50	9	100	6	5.85	●

Side Milling

Work Material		GR.5 Hardened Steel (38-48HRC)				GR.6 Hardened Steel (48-56HRC)				GR.7 Hardened Steel (56-68HRC)			
		RPM (min-1)	Feed (mm/min)	ap (mm)	ae (mm)	RPM (min-1)	Feed (mm/min)	ap (mm)	ae (mm)	RPM (min-1)	Feed (mm/min)	ap (mm)	ae (mm)
F694TX	1×3	14,000	1,350	0.04	0.3	13,000	1,100	0.035	0.25	8,800	700	0.02	0.25
F694TX	1×4	13,800	1,310	0.039	0.270	12,000	1,070	0.031	0.243	8,500	640	0.015	0.243
F694TX	1×6	11,300	1,040	0.021	0.216	9,800	860	0.016	0.209	7,000	510	0.01	0.108
F694TX	1×8	9,800	780	0.02	0.189	8,500	720	0.012	0.16	6,100	420	0.008	0.094
F694TX	1×10	8,800	510	0.011	0.126	7,600	510	0.009	0.1	5,400	350	0.006	0.05
F694TX	1×12	8,300	490	0.01	0.1	7,200	490	0.005	0.1	5,000	300	0.003	0.05
F694TX	1.5×4	12,000	1,300	0.045	0.5	12,000	1,250	0.045	0.5	9,000	500	0.03	0.25
F694TX	1.5×6	11,600	1,280	0.041	0.486	10,600	1,210	0.038	0.445	8,100	460	0.025	0.202
F694TX	1.5×8	10,200	1,080	0.038	0.35	9,300	1,020	0.031	0.346	7,100	390	0.015	0.157
F694TX	1.5×10	9,000	900	0.03	0.3	8,200	800	0.03	0.3	6,500	360	0.01	0.1
F694TX	1.5×12	8,500	830	0.029	0.324	7,800	780	0.026	0.297	5,900	300	0.01	0.162
F694TX	1.5×16	7,400	670	0.018	0.216	6,800	600	0.014	0.198	5,100	230	0.005	0.108
F694TX	2×6	12,800	1,280	0.064	0.648	12,000	1,200	0.06	0.729	9,700	700	0.028	0.324
F694TX	2×8	11,200	1,160	0.058	0.612	10,400	1,100	0.055	0.648	8,400	600	0.026	0.288
F694TX	2×10	10,000	1,100	0.045	0.5	9,000	1,000	0.045	0.5	8,200	500	0.02	0.25
F694TX	2×12	9,100	1,030	0.046	0.405	8,500	960	0.044	0.405	6,900	420	0.018	0.180
F694TX	2×16	7,800	860	0.042	0.283	7,300	700	0.039	0.315	5,900	270	0.016	0.157
F694TX	2×20	7,000	800	0.025	0.198	6,600	650	0.024	0.198	5,300	290	0.007	0.116
F694TX	2×25	6,500	650	0.02	0.15	6,500	600	0.02	0.15	5,000	200	0.005	0.08
F694TX	2×30	6,000	500	0.02	0.1	6,000	450	0.02	0.1	4,500	150	0.003	0.05
F694TX	3×8	11,250	2,300	0.1	0.65	11,000	2,000	0.08	0.65	9,000	750	0.05	0.5
F694TX	3×10	11,250	2,277	0.0945	0.63	10,620	1,980	0.063	0.63	8,910	729	0.0423	0.45
F694TX	3×12	10,500	2,020	0.084	0.670	10,000	1,950	0.052	0.67	8,100	660	0.037	0.5
F694TX	3×16	9,200	1,680	0.064	0.634	8,800	1,600	0.04	0.63	7,100	570	0.027	0.378
F694TX	3×20	8,400	1,540	0.058	0.580	7,900	1,490	0.036	0.58	6,300	550	0.022	0.319
F694TX	3×25	7,500	1,350	0.05	0.4	7,000	1,100	0.025	0.4	6,000	450	0.01	0.2
F694TX	3×30	7,000	1,260	0.04	0.38	6,500	1,230	0.015	0.38	5,400	390	0.007	0.144
F694TX	4×12	8,500	1,400	0.1	1.0	7,100	1,350	0.078	1.08	6,000	760	0.051	0.76
F694TX	4×16	7,900	1,370	0.091	1.0	6,600	1,330	0.071	1.0	5,600	740	0.043	0.7
F694TX	4×20	6,200	1,200	0.06	0.8	5,200	1,120	0.047	0.8	4,500	630	0.022	0.56
F694TX	4×25	6,200	1,200	0.06	0.8	5,200	1,120	0.047	0.8	4,500	630	0.022	0.56
F694TX	4×30	5,500	960	0.037	0.648	4,600	920	0.029	0.648	3,900	600	0.011	0.388
F694TX	4×40	5,000	800	0.03	0.5	4,300	800	0.025	0.5	3,500	500	0.005	0.3
F694TX	5×16	8,000	1,100	0.15	1.0	8,000	1,100	0.15	1.0	5,500	700	0.05	0.6
F694TX	5×20	7,500	900	0.1	1.0	7,500	900	0.1	1.0	5,200	680	0.03	0.5
F694TX	5×30	6,500	700	0.08	0.5	6,500	700	0.08	0.5	4,800	630	0.02	0.3
F694TX	5×40	5,500	600	0.05	0.3	5,500	600	0.05	0.3	4,500	600	0.01	0.2
F694TX	6×20	7,000	1,000	0.3	1.2	7,000	1,000	0.3	1.2	5,000	650	0.05	0.6
F694TX	6×30	6,500	800	0.2	1.0	6,500	800	0.2	1.0	4,700	620	0.03	0.5
F694TX	6×40	6,000	700	0.15	0.8	6,000	700	0.15	0.8	4,400	580	0.02	0.3
F694TX	6×50	5,500	600	0.1	0.6	5,500	600	0.1	0.6	4,100	550	0.01	0.2

(mm)

1. Please work with good rigidity / high precision facilities and collet chuck.
2. Please choose proper cutting fluid.
3. The cutting data is reference value only. Please adjust it according to your real working conditions.
4. If RPM is lower the reference value, the Feed rate (fz) and RPM should be reduced by the same proportion.
5. If vibration occurs during cutting, please reduce cutting parameter.

F690TX

Toric End Mills For Rib Processing With Corner Radius

Code No. F690TX-Dc×R×L1

SMG Carbide

AlTiSiN TX

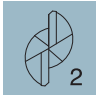
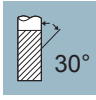

Type of Operation



Work Material

P	H	M	K	N	S
●	●	●	○	○	○

P Steel

H <38HRC Hardened Steel

H <48HRC Hardened Steel

H <56HRC Hardened Steel

H <68HRC Hardened Steel

K Cast Iron

N Copper

Feature of product:

End Mills For Rib Processing with Corner Radius- 2 Flutes

Widely used in high precision mold, deep machining angle clean with long neck and micro 3D curved surface.

Good wear resistance and lubricating effect with Nano multilayer coating.

High precision R value and available with complete size range.

Workable for various steel materials and copper electrode materials.



Dc	R	L1	Lc	L	d	D1	AlTiSiN	Dc	R	L1	Lc	L	d	D1	AlTiSiN
0-0.02	±0.005	mm	mm	mm	h5	mm	F690TX	0-0.02	±0.005	mm	mm	mm	h5	mm	F690TX
0.2	R0.02	0.50	15	50	4	0.18	●	0.8	R0.2	4	0.65	50	4	0.75	●
0.2	R0.02	1	0.15	50	4	0.18	●	0.8	R0.2	6	0.65	50	4	0.75	●
0.2	R0.02	2	0.15	50	4	0.18	●	0.8	R0.2	8	0.65	50	4	0.75	●
0.2	R0.05	0.50	15	50	4	0.18	●	0.8	R0.2	12	0.65	50	4	0.75	●
0.2	R0.05	1	0.15	50	4	0.18	●	1	R0.02	2	0.8	50	4	0.95	●
0.2	R0.05	2	0.15	50	4	0.18	●	1	R0.02	4	0.8	50	4	0.95	●
0.3	R0.02	1	0.25	50	4	0.28	●	1	R0.02	6	0.8	50	4	0.95	●
0.3	R0.02	2	0.25	50	4	0.28	●	1	R0.02	8	0.8	50	4	0.95	●
0.3	R0.02	3	0.25	50	4	0.28	●	1	R0.02	10	0.8	50	4	0.95	●
0.3	R0.05	1	0.25	50	4	0.28	●	1	R0.02	12	0.8	50	4	0.95	●
0.3	R0.05	2	0.25	50	4	0.28	●	1	R0.05	2	0.8	50	4	0.95	●
0.3	R0.05	3	0.25	50	4	0.28	●	1	R0.05	4	0.8	50	4	0.95	●
0.4	R0.02	1	0.3	50	4	0.37	●	1	R0.05	6	0.8	50	4	0.95	●
0.4	R0.02	2	0.3	50	4	0.37	●	1	R0.05	8	0.8	50	4	0.95	●
0.4	R0.02	3	0.3	50	4	0.37	●	1	R0.05	10	0.8	50	4	0.95	●
0.4	R0.02	4	0.3	50	4	0.37	●	1	R0.05	12	0.8	50	4	0.95	●
0.4	R0.05	1	0.3	50	4	0.37	●	1	R0.1	2	0.8	50	4	0.95	●
0.4	R0.05	2	0.3	50	4	0.37	●	1	R0.1	4	0.8	50	4	0.95	●
0.4	R0.05	3	0.3	50	4	0.37	●	1	R0.1	6	0.8	50	4	0.95	●
0.4	R0.05	4	0.3	50	4	0.37	●	1	R0.1	8	0.8	50	4	0.95	●
0.4	R0.1	1	0.3	50	4	0.37	●	1	R0.1	10	0.8	50	4	0.95	●
0.4	R0.1	2	0.3	50	4	0.37	●	1	R0.1	12	0.8	50	4	0.95	●
0.4	R0.1	3	0.3	50	4	0.37	●	1	R0.2	2	0.8	50	4	0.95	●
0.4	R0.1	4	0.3	50	4	0.37	●	1	R0.2	4	0.8	50	4	0.95	●
0.5	R0.02	1	0.4	50	4	0.46	●	1	R0.2	6	0.8	50	4	0.95	●
0.5	R0.02	2	0.4	50	4	0.46	●	1	R0.2	8	0.8	50	4	0.95	●
0.5	R0.02	3	0.4	50	4	0.46	●	1	R0.2	10	0.8	50	4	0.95	●
0.5	R0.02	4	0.4	50	4	0.46	●	1	R0.2	12	0.8	50	4	0.95	●
0.5	R0.02	5	0.4	50	4	0.46	●	1	R0.3	2	0.8	50	4	0.95	●
0.5	R0.02	6	0.4	50	4	0.46	●	1	R0.3	4	0.8	50	4	0.95	●
0.5	R0.05	1	0.4	50	4	0.46	●	1	R0.3	6	0.8	50	4	0.95	●
0.5	R0.05	2	0.4	50	4	0.46	●	1	R0.3	8	0.8	50	4	0.95	●
0.5	R0.05	3	0.4	50	4	0.46	●	1	R0.3	10	0.8	50	4	0.95	●
0.5	R0.05	4	0.4	50	4	0.46	●	1	R0.3	12	0.8	50	4	0.95	●
0.5	R0.05	5	0.4	50	4	0.46	●	1.2	R0.2	6	1	50	4	1.15	●
0.5	R0.05	6	0.4	50	4	0.46	●	1.2	R0.2	8	1	50	4	1.15	●
0.5	R0.1	1	0.4	50	4	0.46	●	1.2	R0.2	10	1	50	4	1.15	●
0.5	R0.1	2	0.4	50	4	0.46	●	1.5	R0.1	4	1.2	50	4	1.45	●
0.5	R0.1	3	0.4	50	4	0.46	●	1.5	R0.1	6	1.2	50	4	1.45	●
0.5	R0.1	4	0.4	50	4	0.46	●	1.5	R0.1	8	1.2	50	4	1.45	●
0.5	R0.1	5	0.4	50	4	0.46	●	1.5	R0.1	10	1.2	50	4	1.45	●
0.5	R0.1	6	0.4	50	4	0.46	●	1.5	R0.1	12	1.2	50	4	1.45	●
0.6	R0.02	2	0.5	50	4	0.55	●	1.5	R0.1	16	1.2	50	4	1.45	●
0.6	R0.02	4	0.5	50	4	0.55	●	1.5	R0.2	4	1.2	50	4	1.45	●
0.6	R0.02	6	0.5	50	4	0.55	●	1.5	R0.2	6	1.2	50	4	1.45	●
0.6	R0.02	8	0.5	50	4	0.55	●	1.5	R0.2	8	1.2	50	4	1.45	●
0.6	R0.05	2	0.5	50	4	0.55	●	1.5	R0.2	10	1.2	50	4	1.45	●
0.6	R0.05	4	0.5	50	4	0.55	●	1.5	R0.2	12	1.2	50	4	1.45	●
0.6	R0.05	6	0.5	50	4	0.55	●	1.5	R0.2	16	1.2	50	4	1.45	●
0.6	R0.05	8	0.5	50	4	0.55	●	1.5	R0.3	4	1.2	50	4	1.45	●
0.6	R0.1	2	0.5	50	4	0.55	●	1.5	R0.3	6	1.2	50	4	1.45	●
0.6	R0.1	4	0.5	50	4	0.55	●	1.5	R0.3	8	1.2	50	4	1.45	●
0.6	R0.1	6	0.5	50	4	0.55	●	1.5	R0.3	10	1.2	50	4	1.45	●
0.6	R0.1	8	0.5	50	4	0.55	●	1.5	R0.3	12	1.2	50	4	1.45	●
0.8	R0.02	2	0.65	50	4	0.75	●	1.5	R0.3	16	1.2	50	4	1.45	●
0.8	R0.02	4	0.65	50	4	0.75	●	2	R0.1	4	1.6	50	4	1.95	●
0.8	R0.02	6	0.65	50	4	0.75	●	2	R0.1	6	1.6	50	4	1.95	●
0.8	R0.02	8	0.65	50	4	0.75	●	2	R0.1	8	1.6	50	4	1.95	●
0.8	R0.02	12	0.65	50	4	0.75	●	2	R0.1	10	1.6	50	4	1.95	●
0.8	R0.05	2	0.65	50	4	0.75	●	2	R0.1	12	1.6	50	4	1.95	●
0.8	R0.05	4	0.65	50	4	0.75	●	2	R0.1	16	1.6	50	4	1.95	●
0.8	R0.05	6	0.65	50	4	0.75	●	2	R0.1	20	1.6	60	4	1.95	●
0.8	R0.05	8	0.65	50	4	0.75	●	2	R0.2	4	1.6	50	4	1.95	●
0.8	R0.05	12	0.65	50	4	0.75	●	2	R0.2	6	1.6	50	4	1.95	●
0.8	R0.1	2	0.65	50	4	0.75	●	2	R0.2	8	1.6	50	4	1.95	●
0.8	R0.1	4	0.65	50	4	0.75	●	2	R0.2	10	1.6	50	4	1.95	●
0.8	R0.1	6	0.65	50	4	0.75	●	2	R0.2	12	1.6	50	4	1.95	●
0.8	R0.1	8	0.65	50	4	0.75	●	2	R0.2	16	1.6	50	4	1.95	●
0.8	R0.1	12	0.65	50	4	0.75	●	2	R0.2	20	1.6	60	4	1.95	●
0.8	R0.2	2	0.65	50	4	0.75	●	2	R0.3	4	1.6	50	4	1.95	●

Side Milling

Work Material	Dc×Ll	GR.1 / GR.2 / GR.3 Carbon Steel / Low-alloyed Steel / Hi-alloyed Steel (-24HRC) (-30HRC)				GR.4 / GR.5 Hardened Steel / Hardened Steel (38-48HRC) (30-38HRC)				GR.6 Hardened Steel (48-56HRC)				GR.7 Hardened Steel (56-68HRC)			
		RPM (min-1)	Feed (mm/min)	ap (mm)	ae (mm)	RPM (min-1)	Feed (mm/min)	ap (mm)	ae (mm)	RPM (min-1)	Feed (mm/min)	ap (mm)	ae (mm)	RPM (min-1)	Feed (mm/min)	ap (mm)	ae (mm)
F690TX	0.2×0.5	38,500	550	0.01	0.05	35000	500	0.01	0.05	31500	400	0.01	0.05	47775	30	0.01	0.05
F690TX	0.2×1	38,115	528	0.008	0.03	34650	480	0.008	0.03	31185	384	0.008	0.03	39812.5	20	0.008	0.03
F690TX	0.2×2	37,026	495	0.005	0.02	33660	450	0.005	0.02	30294	360	0.005	0.02	31850	10	0.005	0.02
F690TX	0.3×1	37,785	638	0.015	0.07	34350	580	0.015	0.07	30915	464	0.015	0.07	31850	30	0.015	0.07
F690TX	0.3×2	36,740	605	0.012	0.06	33400	550	0.012	0.06	30060	440	0.012	0.06	26541.667	20	0.012	0.06
F690TX	0.3×3	30,448	572	0.01	0.05	27680	520	0.01	0.05	24912	416	0.01	0.05	21233.333	10	0.01	0.05
F690TX	0.4×1	36,960	704	0.02	0.1	33600	640	0.02	0.1	30240	512	0.02	0.1	23887.5	50	0.02	0.1
F690TX	0.4×2	35,750	682	0.018	0.08	32500	620	0.018	0.08	29250	496	0.018	0.08	19906.25	45	0.018	0.08
F690TX	0.4×3	29,480	660	0.015	0.06	26800	600	0.015	0.06	24120	480	0.015	0.06	15925	40	0.015	0.06
F690TX	0.4×4	26,785	638	0.01	0.05	24350	580	0.01	0.05	21915	464	0.01	0.05	14332.5	30	0.01	0.05
F690TX	0.5×1	35,200	748	0.03	0.12	32,000	680	0.03	0.12	28800	544	0.03	0.12	21500	70	0.03	0.12
F690TX	0.5×2	35,112	730	0.029	0.117	31,920	664	0.029	0.117	28728	531	0.026	0.117	20,100	68	0.011	0.117
F690TX	0.5×3	28,072	563	0.023	0.113	25,520	512	0.023	0.113	22968	410	0.020	0.113	16,100	52	0.008	0.113
F690TX	0.5×4	25,608	484	0.016	0.108	23,280	440	0.016	0.108	20952	352	0.014	0.108	14,600	45	0.006	0.108
F690TX	0.5×5	23,232	414	0.011	0.099	21,120	376	0.011	0.099	19008	301	0.010	0.099	13,300	39	0.004	0.099
F690TX	0.5×6	21,296	352	0.007	0.090	19,360	320	0.007	0.090	17424	256	0.006	0.090	12,200	33	0.003	0.090
F690TX	0.6×2	25,168	449	0.010	0.219	22,880	408	0.010	0.219	20592	326	0.010	0.219	15,200	43	0.004	0.219
F690TX	0.6×4	17,952	290	0.005	0.104	16,320	264	0.005	0.104	14688	211	0.005	0.104	10,800	28	0.002	0.1035
F690TX	0.6×6	14,784	220	0.003	0.099	13,440	200	0.003	0.099	12096	160	0.003	0.099	8,900	21	0.001	0.099
F690TX	0.6×8	13,695	198	0.003	0.05	12,450	180	0.003	0.08	11205	144	0.003	0.08	10,617	20	0.001	0.08
F690TX	0.8×4	15,400	396	0.014	0.117	14,000	360	0.014	0.117	12600	288	0.015	0.117	10,200	41	0.007	0.117
F690TX	0.8×6	12,848	299	0.008	0.108	11,680	272	0.008	0.108	10512	218	0.008	0.108	8,500	30	0.004	0.108
F690TX	0.8×8	11,264	238	0.005	0.090	10,240	216	0.005	0.090	9216	173	0.004	0.090	7,600	20	0.002	0.090
F690TX	0.8×12	10,780	220	0.003	0.08	9,800	200	0.003	0.08	8820	160	0.003	0.08	6,370	15	0.001	0.05
F690TX	1×2	14,014	770	0.03	0.9	12,740	700	0.03	0.9	11466	560	0.03	0.9	5,308	90	0.02	0.3
F690TX	1×4	12,144	722	0.030	0.870	11,040	656	0.030	0.870	9936	525	0.035	0.270	8,500	80	0.017	0.270
F690TX	1×6	9,944	572	0.021	0.216	9,040	520	0.021	0.216	8136	416	0.024	0.216	7,000	64	0.012	0.216
F690TX	1×8	8,624	431	0.016	0.189	7,840	392	0.016	0.189	7056	314	0.018	0.189	6,100	48	0.009	0.189
F690TX	1×10	7,744	282	0.011	0.126	7,040	256	0.011	0.126	6336	205	0.013	0.126	5,400	32	0.006	0.126
F690TX	1×12	7,128	185	0.008	0.072	6,480	168	0.008	0.072	5832	134	0.009	0.072	5,000	21	0.004	0.072
F690TX	1.2×6	8,272	510	0.018	0.090	7,520	464	0.018	0.090	6768	371	0.022	0.090	6,200	60	0.011	0.090
F690TX	1.2×8	8,272	510	0.018	0.090	7,520	464	0.018	0.090	6768	371	0.022	0.090	6,200	60	0.011	0.090
F690TX	1.2×10	5,984	326	0.007	0.072	5,440	296	0.007	0.072	4896	237	0.008	0.072	4,500	38	0.004	0.072
F690TX	1.5×4	11,616	959	0.045	0.450	10,560	872	0.045	0.450	9504	698	0.060	0.450	9,200	124	0.033	0.450
F690TX	1.5×6	9,328	906	0.041	0.405	8,480	824	0.041	0.405	7632	659	0.055	0.405	7,400	117	0.090	0.405
F690TX	1.5×8	8,184	766	0.034	0.315	7,440	696	0.034	0.315	6696	557	0.045	0.315	6,500	99	0.025	0.315
F690TX	1.5×10	7,480	660	0.032	0.288	6,800	600	0.032	0.288	6120	480	0.042	0.288	6,000	85	0.023	0.288
F690TX	1.5×12	6,864	590	0.029	0.270	6,240	536	0.029	0.270	5616	429	0.038	0.270	5,400	76	0.021	0.270
F690TX	1.5×16	5,984	449	0.015	0.180	5,440	408	0.015	0.180	4896	326	0.020	0.180	4,700	58	0.011	0.180
F690TX	2×4	12,650	935	0.05	0.8	11,500	850	0.05	0.8	10350	680	0.05	0.8	11,148	140	0.04	0.85
F690TX	2×6	11,264	898	0.043	0.810	10,240	816	0.043	0.810	9216	653	0.060	0.810	9,700	133	0.036	0.810
F690TX	2×8	9,856	818	0.039	0.720	8,960	744	0.039	0.720	8064	595	0.055	0.720	8,400	121	0.033	0.720
F690TX	2×10	8,800	766	0.033	0.585	8,000	696	0.033	0.585	7200	557	0.047	0.585	7,600	113	0.028	0.585
F690TX	2×12	8,008	722	0.031	0.450	7,280	656	0.031	0.450	6552	525	0.044	0.450	6,900	107	0.026	0.450

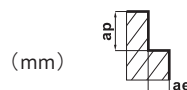

1. Please work with good rigidity / high precision facilities and collet chuck.
2. Please choose proper cutting fluid.
3. The cutting data is reference value only. Please adjust it according to your real working conditions.
4. If RPM is lower the reference value, the Feed rate (fz) and RPM should be reduced by the same proportion.
5. If vibration occurs during cutting, please reduce cutting parameter.

F690TX

Toric End Mills For Rib Processing With Corner Radius

Code No. F690TX-Dc×R×L1

SMG Carbide

AlTiSiN TX



Type of Operation



Work Material

P	H	M	K	N	S
●	●	●	○	○	○

P Steel

H <38HRC Hardened Steel

H <48HRC Hardened Steel

H <56HRC Hardened Steel

H <68HRC Hardened Steel

K Cast Iron

N Copper



Dc	R	L1	Lc	L	d	D1	AlTiSiN	Dc	R	L1	Lc	L	d	D1	AlTiSiN
$\begin{smallmatrix} 0 \\ -0.02 \end{smallmatrix}$	± 0.005	mm	mm	mm	h5	mm	F690TX	$\begin{smallmatrix} 0 \\ -0.02 \end{smallmatrix}$	± 0.005	mm	mm	mm	h5	mm	F690TX
2	R0.3	6	1.6	50	4	1.95	●	4	R0.5	8	4	60	6	3.85	●
2	R0.3	8	1.6	50	4	1.95	●	4	R0.5	12	4	60	6	3.85	●
2	R0.3	10	1.6	50	4	1.95	●	4	R0.5	16	4	60	6	3.85	●
2	R0.3	12	1.6	50	4	1.95	●	4	R0.5	20	4	70	6	3.85	●
2	R0.3	16	1.6	50	4	1.95	●	4	R0.5	25	4	70	6	3.85	●
2	R0.3	20	1.6	60	4	1.95	●	4	R0.5	30	4	80	6	3.85	●
2	R0.5	4	1.6	50	4	1.95	●	4	R0.5	40	4	90	6	3.85	●
2	R0.5	6	1.6	50	4	1.95	●	4	R1	8	4	60	6	3.85	●
2	R0.5	8	1.6	50	4	1.95	●	4	R1	12	4	60	6	3.85	●
2	R0.5	10	1.6	50	4	1.95	●	4	R1	16	4	60	6	3.85	●
2	R0.5	12	1.6	50	4	1.95	●	4	R1	20	4	70	6	3.85	●
2	R0.5	16	1.6	50	4	1.95	●	4	R1	25	4	70	6	3.85	●
2	R0.5	20	1.6	60	4	1.95	●	4	R1	30	4	80	6	3.85	●
3	R0.1	6	2.5	50	6	2.85	●	4	R1	40	4	90	6	3.85	●
3	R0.1	8	2.5	50	6	2.85	●	5	R0.2	20	4	70	6	4.85	●
3	R0.1	12	2.5	50	6	2.85	●	5	R0.2	40	4	90	6	4.85	●
3	R0.1	16	2.5	60	6	2.85	●	5	R0.3	20	4	70	6	4.85	●
3	R0.1	20	2.5	60	6	2.85	●	5	R0.3	40	4	90	6	4.85	●
3	R0.1	25	2.5	70	6	2.85	●	5	R0.5	20	4	70	6	4.85	●
3	R0.1	30	2.5	70	6	2.85	●	5	R0.5	40	4	90	6	4.85	●
3	R0.2	6	2.5	50	6	2.85	●	5	R1	20	4	70	6	4.85	●
3	R0.2	8	2.5	50	6	2.85	●	5	R1	40	4	90	6	4.85	●
3	R0.2	12	2.5	50	6	2.85	●	6	R0.2	12	5	60	6	5.85	●
3	R0.2	16	2.5	60	6	2.85	●	6	R0.2	18	5	60	6	5.85	●
3	R0.2	20	2.5	60	6	2.85	●	6	R0.2	24	5	70	6	5.85	●
3	R0.2	25	2.5	70	6	2.85	●	6	R0.2	36	5	80	6	5.85	●
3	R0.2	30	2.5	70	6	2.85	●	6	R0.2	54	5	100	6	5.85	●
3	R0.3	6	2.5	50	6	2.85	●	6	R0.3	12	5	60	6	5.85	●
3	R0.3	8	2.5	50	6	2.85	●	6	R0.3	18	5	60	6	5.85	●
3	R0.3	12	2.5	50	6	2.85	●	6	R0.3	24	5	70	6	5.85	●
3	R0.3	16	2.5	60	6	2.85	●	6	R0.3	36	5	80	6	5.85	●
3	R0.3	20	2.5	60	6	2.85	●	6	R0.3	54	5	100	6	5.85	●
3	R0.3	25	2.5	70	6	2.85	●	6	R0.5	12	5	60	6	5.85	●
3	R0.3	30	2.5	70	6	2.85	●	6	R0.5	18	5	60	6	5.85	●
3	R0.5	6	2.5	50	6	2.85	●	6	R0.5	24	5	70	6	5.85	●
3	R0.5	8	2.5	50	6	2.85	●	6	R0.5	36	5	80	6	5.85	●
3	R0.5	12	2.5	50	6	2.85	●	6	R0.5	54	5	100	6	5.85	●
3	R0.5	16	2.5	60	6	2.85	●	6	R1	12	5	60	6	5.85	●
3	R0.5	20	2.5	60	6	2.85	●	6	R1	18	5	60	6	5.85	●
3	R0.5	25	2.5	70	6	2.85	●	6	R1	24	5	70	6	5.85	●
3	R0.5	30	2.5	70	6	2.85	●	6	R1	36	5	80	6	5.85	●
4	R0.1	8	4	60	6	3.85	●	6	R1	54	5	100	6	5.85	●
4	R0.1	12	4	60	6	3.85	●								
4	R0.1	16	4	60	6	3.85	●								
4	R0.1	20	4	70	6	3.85	●								
4	R0.1	25	4	70	6	3.85	●								
4	R0.1	30	4	80	6	3.85	●								
4	R0.1	40	4	90	6	3.85	●								
4	R0.2	8	4	60	6	3.85	●								
4	R0.2	12	4	60	6	3.85	●								
4	R0.2	16	4	60	6	3.85	●								
4	R0.2	20	4	70	6	3.85	●								
4	R0.2	25	4	70	6	3.85	●								
4	R0.2	30	4	80	6	3.85	●								
4	R0.2	40	4	90	6	3.85	●								
4	R0.3	8	4	60	6	3.85	●								
4	R0.3	12	4	60	6	3.85	●								
4	R0.3	16	4	60	6	3.85	●								
4	R0.3	20	4	70	6	3.85	●								
4	R0.3	25	4	70	6	3.85	●								
4	R0.3	30	4	80	6	3.85	●								
4	R0.3	40	4	90	6	3.85	●								

Feature of product:

End Mills For Rib Processing with Corner Radius- 2 Flutes

Widely used in high precision mold, deep machining angle clean with long neck and micro 3D curved surface.

Good wear resistance and lubricating effect with Nano multilayer coating.

High precision R value and available with complete size range.

Workable for various steel materials and copper electrode materials.

Side Milling

Work Material		GR.1 / GR.2 / GR.3 Carbon Steel / Low-alloyed Steel / Hi-alloyed Steel (~24HRC) (~30HRC)				GR.4 / GR.5 Hardened Steel / Hardened Steel (38~48HRC) (30~38HRC)				GR.6 Hardened Steel (48~56HRC)				GR.7 Hardened Steel (56~68HRC)			
		RPM (min-1)	Feed (mm/min)	ap (mm)	ae (mm)	RPM (min-1)	Feed (mm/min)	ap (mm)	ae (mm)	RPM (min-1)	Feed (mm/min)	ap (mm)	ae (mm)	RPM (min-1)	Feed (mm/min)	ap (mm)	ae (mm)
F690TX	2×16	6,864	607	0.028	0.315	6,240	552	0.028	0.315	5616	442	0.039	0.315	5,900	90	0.023	0.315
F690TX	2×20	6,160	563	0.017	0.198	5,600	512	0.017	0.198	5040	410	0.024	0.198	5,300	84	0.014	0.198
F690TX	3×6	13,200	1,375	0.15	0.8	12,000	1,250	0.15	0.8	10800	1000	0.15	0.8	12,740	300	0.15	0.8
F690TX	3×8	12,320	1,329	0.15	0.72	11,200	1,208	0.15	0.72	10080	966	0.15	0.72	12,000	270	0.1	0.72
F690TX	3×12	9,240	1,012	0.105	0.670	8,400	920	0.105	0.670	7560	736	0.105	0.670	9,000	200	0.075	0.670
F690TX	3×16	8,096	845	0.081	0.630	7,360	768	0.081	0.630	6624	614	0.081	0.630	7,900	173	0.054	0.630
F690TX	3×20	7,392	774	0.073	0.580	6,720	704	0.073	0.580	6048	563	0.073	0.580	7,100	150	0.044	0.580
F690TX	3×25	6,600	722	0.065	0.495	6,000	656	0.065	0.495	5400	525	0.065	0.495	6,400	146	0.043	0.495
F690TX	3×30	6,160	634	0.050	0.380	5,600	576	0.050	0.380	5040	461	0.050	0.380	6,000	118	0.029	0.360
F690TX	4×8	8,800	990	0.1	1.2	8,000	900	0.1	1.2	7200	720	0.1	1.2	7,963	230	0.09	1.3
F690TX	4×12	7,832	950	0.083	1.150	7,120	864	0.083	1.150	6408	691	0.120	1.150	6,400	215	0.085	1.150
F690TX	4×16	6,952	906	0.065	1.000	6,320	824	0.065	1.000	5688	659	0.100	1.000	5,600	205	0.065	1.000
F690TX	4×20	6,072	871	0.054	0.900	5,520	792	0.054	0.900	4968	634	0.080	0.900	4,900	198	0.058	0.900
F690TX	4×25	5,456	792	0.043	0.8	4,960	720	0.043	0.8	4464	576	0.065	0.8	4,500	175	0.043	0.8
F690TX	4×30	4,840	634	0.027	0.648	4,400	576	0.027	0.648	3960	461	0.04	0.6	3,900	144	0.029	0.648
F690TX	4×40	4,048	317	0.007	0.315	3,680	288	0.007	0.315	3312	230	0.01	0.315	3,300	72	0.007	0.315
F690TX	5×20	7,007	935	0.05	0.9	6,370	850	0.05	0.9	5733	680	0.05	0.9	6,370	250	0.06	0.9
F690TX	5×40	5,606	770	0.01	0.3	5,096	700	0.01	0.3	4586	560	0.01	0.3	5,733	90	0.03	0.3
F690TX	6×12	5,830	946	0.1	1.0	5,300	860	0.1	1.0	4770	688	0.1	1.0	5,308	200	0.1	1.0
F690TX	6×18	5,170	880	0.05	0.9	4,700	800	0.05	0.9	4230	640	0.05	0.9	4,778	160	0.05	0.9
F690TX	6×24	4,620	770	0.04	0.8	4,200	700	0.04	0.8	3780	560	0.04	0.8	4,247	130	0.04	0.8
F690TX	6×36	4,070	517	0.02	0.6	3,700	470	0.02	0.6	3330	376	0.02	0.6	3,716	120	0.02	0.6
F690TX	6×54	3,498	275	0.01	0.3	3,180	250	0.01	0.3	2862	200	0.01	0.3	3,185	90	0.01	0.3

(mm)

1. Please work with good rigidity / high precision facilities and collet chuck.
2. Please choose proper cutting fluid.
3. The cutting data is reference value only. Please adjust it according to your real working conditions.
4. If RPM is lower the reference value, the Feed rate (fz) and RPM should be reduced by the same proportion.
5. If vibration occurs during cutting, please reduce cutting parameter.

F693TX

Toric End Mills For Rib Processing With Corner Radius

Code No. F693TX-Dc×R×L1

SMG Carbide

AlTiSiN TX



Type of Operation



Work Material

P	H	M	K	N	S
	●				

H <48HRC Hardened Steel

H <56HRC Hardened Steel

H <68HRC Hardened Steel

Feature of product:

- End Mills For Rib Processing with Corner Radius- 4 Flutes
- Widely used in high precision mold, deep machining angle clean with long neck and micro 3D curved surface.
- Good wear resistance and lubricating effect with Nano multilayer coating.
- High precision R value and available with complete size range.
- Workable for various steel materials and copper electrode materials.



Dc	R	L1	Lc	L	d	D1	AlTiSiN	Dc	R	L1	Lc	L	d	D1	AlTiSiN
0.02	±0.005	mm	mm	mm	h5	mm	F693TX	0.02	±0.005	mm	mm	mm	h5	mm	F693TX
1	R0.1	4	0.8	50	4	0.95	●	3	R0.3	12	2.5	50	6	2.85	●
1	R0.1	6	0.8	50	4	0.95	●	3	R0.3	16	2.5	60	6	2.85	●
1	R0.1	8	0.8	50	4	0.95	●	3	R0.3	20	2.5	60	6	2.85	●
1	R0.1	10	0.8	50	4	0.95	●	3	R0.3	25	2.5	70	6	2.85	●
1	R0.1	12	0.8	50	4	0.95	●	3	R0.3	30	2.5	70	6	2.85	●
1	R0.2	4	0.8	50	4	0.95	●	3	R0.5	8	2.5	50	6	2.85	●
1	R0.2	6	0.8	50	4	0.95	●	3	R0.5	12	2.5	50	6	2.85	●
1	R0.2	8	0.8	50	4	0.95	●	3	R0.5	16	2.5	60	6	2.85	●
1	R0.2	10	0.8	50	4	0.95	●	3	R0.5	20	2.5	60	6	2.85	●
1	R0.2	12	0.8	50	4	0.95	●	3	R0.5	25	2.5	70	6	2.85	●
1	R0.3	4	0.8	50	4	0.95	●	3	R0.5	30	2.5	70	6	2.85	●
1	R0.3	6	0.8	50	4	0.95	●	4	R0.1	12	4	60	6	3.85	●
1	R0.3	8	0.8	50	4	0.95	●	4	R0.1	16	4	60	6	3.85	●
1	R0.3	10	0.8	50	4	0.95	●	4	R0.1	20	4	70	6	3.85	●
1	R0.3	12	0.8	50	4	0.95	●	4	R0.1	30	4	80	6	3.85	●
1.5	R0.1	4	1.2	50	4	1.45	●	4	R0.1	40	4	90	6	3.85	●
1.5	R0.1	6	1.2	50	4	1.45	●	4	R0.2	12	4	60	6	3.85	●
1.5	R0.1	8	1.2	50	4	1.45	●	4	R0.2	16	4	60	6	3.85	●
1.5	R0.1	10	1.2	50	4	1.45	●	4	R0.2	20	4	70	6	3.85	●
1.5	R0.1	12	1.2	50	4	1.45	●	4	R0.2	30	4	80	6	3.85	●
1.5	R0.1	16	1.2	50	4	1.45	●	4	R0.2	40	4	90	6	3.85	●
1.5	R0.2	4	1.2	50	4	1.45	●	4	R0.3	12	4	60	6	3.85	●
1.5	R0.2	6	1.2	50	4	1.45	●	4	R0.3	16	4	60	6	3.85	●
1.5	R0.2	8	1.2	50	4	1.45	●	4	R0.3	20	4	70	6	3.85	●
1.5	R0.2	12	1.2	50	4	1.45	●	4	R0.3	30	4	80	6	3.85	●
1.5	R0.2	16	1.2	50	4	1.45	●	4	R0.3	40	4	90	6	3.85	●
1.5	R0.3	4	1.2	50	4	1.45	●	4	R0.5	12	4	60	6	3.85	●
1.5	R0.3	6	1.2	50	4	1.45	●	4	R0.5	16	4	60	6	3.85	●
1.5	R0.3	8	1.2	50	4	1.45	●	4	R0.5	20	4	70	6	3.85	●
1.5	R0.3	12	1.2	50	4	1.45	●	4	R0.5	30	4	80	6	3.85	●
1.5	R0.3	16	1.2	50	4	1.45	●	4	R0.5	40	4	90	6	3.85	●
2	R0.1	6	1.6	50	4	1.95	●	4	R1	12	4	60	6	3.85	●
2	R0.1	8	1.6	50	4	1.95	●	4	R1	16	4	60	6	3.85	●
2	R0.1	12	1.6	50	4	1.95	●	4	R1	20	4	70	6	3.85	●
2	R0.1	16	1.6	50	4	1.95	●	4	R1	30	4	80	6	3.85	●
2	R0.1	20	1.6	60	4	1.95	●	4	R1	40	4	90	6	3.85	●
2	R0.2	6	1.6	50	4	1.95	●	5	R0.2	20	5	70	6	4.85	●
2	R0.2	8	1.6	50	4	1.95	●	5	R0.2	40	5	90	6	4.85	●
2	R0.2	12	1.6	50	4	1.95	●	5	R0.3	20	5	70	6	4.85	●
2	R0.2	16	1.6	50	4	1.95	●	5	R0.3	40	5	90	6	4.85	●
2	R0.2	20	1.6	60	4	1.95	●	5	R0.5	20	5	70	6	4.85	●
2	R0.3	6	1.6	50	4	1.95	●	5	R0.5	40	5	90	6	4.85	●
2	R0.3	8	1.6	50	4	1.95	●	5	R1	20	5	70	6	4.85	●
2	R0.3	12	1.6	50	4	1.95	●	5	R1	40	5	90	6	4.85	●
2	R0.3	16	1.6	50	4	1.95	●	6	R0.2	36	6	80	6	5.85	●
2	R0.3	20	1.6	60	4	1.95	●	6	R0.2	54	6	100	6	5.85	●
2	R0.5	6	1.6	50	4	1.95	●	6	R0.3	36	6	80	6	5.85	●
2	R0.5	8	1.6	50	4	1.95	●	6	R0.3	54	6	100	6	5.85	●
2	R0.5	12	1.6	50	4	1.95	●	6	R0.5	36	6	80	6	5.85	●
2	R0.5	16	1.6	50	4	1.95	●	6	R0.5	54	6	100	6	5.85	●
2	R0.5	20	1.6	60	4	1.95	●	6	R1	36	6	80	6	5.85	●
3	R0.1	8	2.5	50	6	2.85	●	6	R1	54	6	100	6	5.85	●
3	R0.1	12	2.5	50	6	2.85	●								
3	R0.1	16	2.5	60	6	2.85	●								
3	R0.1	20	2.5	60	6	2.85	●								
3	R0.1	25	2.5	70	6	2.85	●								
3	R0.1	30	2.5	70	6	2.85	●								
3	R0.2	8	2.5	50	6	2.85	●								
3	R0.2	12	2.5	50	6	2.85	●								
3	R0.2	16	2.5	60	6	2.85	●								
3	R0.2	20	2.5	60	6	2.85	●								
3	R0.2	25	2.5	70	6	2.85	●								
3	R0.2	30	2.5	70	6	2.85	●								
3	R0.3	8	2.5	50	6	2.85	●								

Side Milling

Work Material		GR.5 Hardened Steel (38-48HRC)				GR.6 Hardened Steel (48-56HRC)				GR.7 Hardened Steel (56-68HRC)			
Code No.	Dc×Ll	RPM (min-1)	Feed (mm/min)	ap (mm)	ae (mm)	RPM (min-1)	Feed (mm/min)	ap (mm)	ae (mm)	RPM (min-1)	Feed (mm/min)	ap (mm)	ae (mm)
F693TX	1×4	13,800	1,310	0.039	0.270	12,000	1,070	0.031	0.243	8,500	640	0.015	0.243
F693TX	1×6	11,300	1,040	0.021	0.216	9,800	860	0.016	0.209	7,000	510	0.01	0.108
F693TX	1×8	9,800	780	0.02	0.189	8,500	720	0.012	0.16	6,100	420	0.008	0.094
F693TX	1×10	8,800	510	0.011	0.126	7,600	510	0.009	0.1	5,400	350	0.006	0.05
F693TX	1×12	8,000	450	0.01	0.1	7,000	450	0.005	0.05	5,000	300	0.003	0.03
F693TX	1.5×4	13,200	1,360	0.054	0.054	13,200	1,280	0.042	0.495	10,100	700	0.033	0.292
F693TX	1.5×6	11,600	1,280	0.041	0.486	10,600	1,210	0.038	0.445	8,100	460	0.025	0.202
F693TX	1.5×8	10,200	1,080	0.037	0.378	9,300	1,020	0.031	0.346	7,100	390	0.015	0.157
F693TX	1.5×10	9,500	9,000	0.032	0.35	8,800	800	0.03	0.32	6,500	350	0.013	0.15
F693TX	1.5×12	8,500	830	0.029	0.324	7,800	780	0.026	0.297	5,900	300	0.01	0.162
F693TX	1.5×16	7,400	670	0.018	0.216	6,800	600	0.014	0.198	5,100	230	0.005	0.108
F693TX	2×6	12,800	1,280	0.064	0.648	12,000	1,200	0.06	0.729	9,700	700	0.028	0.324
F693TX	2×8	11,200	1,160	0.058	0.612	10,400	1,100	0.055	0.648	8,400	600	0.026	0.288
F693TX	2×12	9,100	1,030	0.046	0.405	8,500	960	0.044	0.405	6,900	420	0.018	0.180
F693TX	2×16	7,800	860	0.042	0.283	7,300	700	0.039	0.315	5,900	270	0.016	0.157
F693TX	2×20	7,000	800	0.025	0.198	6,600	650	0.024	0.198	5,300	290	0.007	0.116
F693TX	3×8	12,500	2,530	0.105	0.7	11,800	2,200	0.07	0.7	9,900	810	0.047	0.50
F693TX	3×12	10,500	2,020	0.084	0.670	10,000	1,950	0.052	0.67	8,100	660	0.037	0.5
F693TX	3×16	9,200	1,680	0.064	0.634	8,800	1,600	0.04	0.63	7,100	570	0.027	0.378
F693TX	3×20	8,400	1,540	0.058	0.580	7,900	1,490	0.036	0.58	6,300	550	0.022	0.319
F693TX	3×25	7,500	1,350	0.05	0.4	7,000	1,100	0.025	0.4	6,000	450	0.01	0.2
F693TX	3×30	7,000	1,260	0.04	0.38	6,500	1,230	0.015	0.38	5,400	390	0.007	0.144
F693TX	4×12	8,500	1,400	0.1	1.0	7,100	1,350	0.078	1.08	6,000	760	0.051	0.76
F693TX	4×16	7,900	1,370	0.091	1.0	6,600	1,330	0.071	1.0	5,600	740	0.043	0.7
F693TX	4×20	6,200	1,200	0.06	0.8	5,200	1,120	0.047	0.8	4,500	630	0.022	0.56
F693TX	4×30	5,500	960	0.037	0.648	4,600	920	0.029	0.648	3,900	600	0.011	0.388
F693TX	4×40	4,125	720	0.027	0.486	3,450	690	0.021	0.486	2,925	450	0.008	0.291
F693TX	5×20	5,800	1,730	0.18	2.358	3,500	1,000	0.1	1.31	3,000	760	0.07	1.31
F693TX	5×40	3,000	800	0.1	1.35	1,700	480	0.1	0.75	1,400	360	0.04	0.5
F693TX	6×36	4,500	1,290	0.158	2.268	2,600	740	0.158	1.260	2,200	580	0.066	1.26
F693TX	6×54	2,000	510	0.05	0.9	1,200	330	0.04	0.5	1,000	240	0.02	0.3

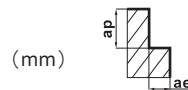

1. Please work with good rigidity / high precision facilities and collet chuck.
2. Please choose proper cutting fluid.
3. The cutting data is reference value only. Please adjust it according to your real working conditions.
4. If RPM is lower the reference value, the Feed rate (fz) and RPM should be reduced by the same proportion.
5. If vibration occurs during cutting, please reduce cutting parameter.

F695TX

Ball Nose End Mills For Rib Processing

Code No. F695TX-RxL1

SMG Carbide

AlTiSiN TX



Type of Operation



Work Material

P	H	M	K	N	S
●	●	●	○	○	○

P Steel

H <38HRC Hardened Steel

H <48HRC Hardened Steel

H <56HRC Hardened Steel

H <68HRC Hardened Steel

K Cast Iron

N Copper

Feature of product:

Ball Nose End Mills For Rib Processing- 2 Flutes
 Widely used in high precision mold, deep machining angle clean with long neck and micro 3D curved surface.
 Good wear resistance and lubricating effect with Nano multilayer coating.
 High precision R value and available with complete size range.
 Workable for various steel materials and copper electrode materials.



R	L1	Lc	L	d	D1	AlTiSiN	R	L1	Lc	L	d	D1	AlTiSiN
±0.005	mm	mm	mm	h5	mm	F695TX	±0.005	mm	mm	mm	h5	mm	F695TX
0.1 R	0.5	0.16	50	4	0.18	●	0.75R	12	1.2	50	4	1.45	●
0.1 R	1	0.16	50	4	0.18	●	0.75R	16	1.2	50	4	1.45	●
0.1 R	1.5	0.16	50	4	0.18	●	0.75R	20	1.2	60	4	1.45	●
0.1 R	2	0.16	50	4	0.18	●	0.75R	25	1.2	60	4	1.45	●
0.1 R	3	0.16	50	4	0.18	●	0.75R	30	1.2	70	4	1.45	●
0.15R	1	0.24	50	4	0.27	●	1 R	3	1.6	50	4	1.45	●
0.15R	1.5	0.24	50	4	0.27	●	1 R	4	1.6	50	4	1.95	●
0.15R	2	0.24	50	4	0.27	●	1 R	6	1.6	50	4	1.95	●
0.15R	3	0.24	50	4	0.27	●	1 R	8	1.6	50	4	1.95	●
0.2 R	1	0.3	50	4	0.37	●	1 R	10	1.6	50	4	1.95	●
0.2 R	1.5	0.3	50	4	0.37	●	1 R	12	1.6	50	4	1.95	●
0.2 R	2	0.3	50	4	0.37	●	1 R	16	1.6	50	4	1.95	●
0.2 R	3	0.3	50	4	0.37	●	1 R	20	1.6	60	4	1.95	●
0.2 R	4	0.3	50	4	0.37	●	1 R	25	1.6	60	4	1.95	●
0.2 R	5	0.3	50	4	0.37	●	1 R	30	1.6	70	4	1.95	●
0.25R	1	0.4	50	4	0.45	●	1 R	35	1.6	75	4	1.95	●
0.25R	2	0.4	50	4	0.45	●	1 R	40	1.6	80	4	1.95	●
0.25R	3	0.4	50	4	0.45	●	1.5 R	6	2.4	50	6	2.85	●
0.25R	4	0.4	50	4	0.45	●	1.5 R	8	2.4	50	6	2.85	●
0.25R	5	0.4	50	4	0.45	●	1.5 R	10	2.4	50	6	2.85	●
0.25R	6	0.4	50	4	0.45	●	1.5 R	12	2.4	50	6	2.85	●
0.25R	8	0.4	50	4	0.45	●	1.5 R	16	2.4	60	6	2.85	●
0.25R	10	0.4	50	4	0.45	●	1.5 R	20	2.4	60	6	2.85	●
0.3 R	1	0.5	50	4	0.55	●	1.5 R	25	2.4	70	6	2.85	●
0.3 R	2	0.5	50	4	0.55	●	1.5 R	30	2.4	70	6	2.85	●
0.3 R	3	0.5	50	4	0.55	●	1.5 R	35	2.4	80	6	2.85	●
0.3 R	4	0.5	50	4	0.55	●	1.5 R	40	2.4	80	6	2.85	●
0.3 R	5	0.5	50	4	0.55	●	2 R	8	3.2	60	6	3.85	●
0.3 R	6	0.5	50	4	0.55	●	2 R	10	3.2	60	6	3.85	●
0.3 R	8	0.5	50	4	0.55	●	2 R	12	3.2	60	6	3.85	●
0.3 R	10	0.5	50	4	0.55	●	2 R	16	3.2	60	6	3.85	●
0.3 R	12	0.5	50	4	0.55	●	2 R	20	3.2	70	6	3.85	●
0.4 R	2	0.6	50	4	0.75	●	2 R	25	3.2	70	6	3.85	●
0.4 R	3	0.6	50	4	0.75	●	2 R	30	3.2	80	6	3.85	●
0.4 R	4	0.6	50	4	0.75	●	2 R	35	3.2	80	6	3.85	●
0.4 R	5	0.6	50	4	0.75	●	2 R	40	3.2	90	6	3.85	●
0.4 R	6	0.6	50	4	0.75	●	2 R	45	3.2	100	6	3.85	●
0.4 R	8	0.6	50	4	0.75	●	2 R	50	3.2	100	6	3.85	●
0.4 R	10	0.6	50	4	0.75	●	2.5 R	10	4	60	6	4.85	●
0.4 R	12	0.6	50	4	0.75	●	2.5 R	20	4	70	6	4.85	●
0.5 R	2	0.8	50	4	0.95	●	2.5 R	30	4	80	6	4.85	●
0.5 R	3	0.8	50	4	0.95	●	2.5 R	40	4	90	6	4.85	●
0.5 R	4	0.8	50	4	0.95	●	2.5 R	50	4	100	6	4.85	●
0.5 R	5	0.8	50	4	0.95	●	3 R	12	4.8	60	6	5.85	●
0.5 R	6	0.8	50	4	0.95	●	3 R	20	4.8	70	6	5.85	●
0.5 R	8	0.8	50	4	0.95	●	3 R	30	4.8	80	6	5.85	●
0.5 R	10	0.8	50	4	0.95	●	3 R	40	4.8	90	6	5.85	●
0.5 R	12	0.8	50	4	0.95	●	3 R	50	4.8	100	6	5.85	●
0.5 R	16	0.8	50	4	0.95	●							
0.5 R	20	0.8	60	4	0.95	●							
0.5 R	25	0.8	60	4	0.95	●							
0.6 R	2	1	50	4	1.15	●							
0.6 R	4	1	50	4	1.15	●							
0.6 R	6	1	50	4	1.15	●							
0.6 R	8	1	50	4	1.15	●							
0.6 R	10	1	50	4	1.15	●							
0.6 R	12	1	50	4	1.15	●							
0.6 R	16	1	50	4	1.15	●							
0.75R	2	1.2	50	4	1.15	●							
0.75R	4	1.2	50	4	1.45	●							
0.75R	6	1.2	50	4	1.45	●							
0.75R	8	1.2	50	4	1.45	●							
0.75R	10	1.2	50	4	1.45	●							
0.75R	12	1.2	50	4	1.45	●							

General processing

Code No.	Work Material	GR.1/GR.2 / GR.3 Carbon Steel/Low-alloyed Steel/Hi-alloyed Steel (-24HRC) (-30HRC)				GR.4 / GR.5 Hardened Steel / Hardened Steel (30-38HRC) (38-48HRC)				GR.6 Hardened Steel (48-56HRC)				GR.7 Hardened Steel (56-68HRC)			
		RPM (min-1)	Feed (mm/min)	ap (mm)	ae (mm)	RPM (min-1)	Feed (mm/min)	ap (mm)	ae (mm)	RPM (min-1)	Feed (mm/min)	ap (mm)	ae (mm)	RPM (min-1)	Feed (mm/min)	ap (mm)	ae (mm)
F695TX-R	0.1R×0.5	50,000	325	0.01	0.01	45,500	273	0.01	0.01	37,800	189	0.01	0.01	35,700	147	0.01	0.01
F695TX-R	0.1R×1.5	45,900	325	0.006	0.006	45,500	273	0.006	0.006	37,800	189	0.006	0.006	35,700	147	0.006	0.006
F695TX-R	0.1R×2	45,900	269	0.006	0.006	45,500	273	0.006	0.006	37,800	189	0.006	0.006	35,700	147	0.006	0.006
F695TX-R	0.1R×3	44,500	212	0.003	0.003	40,500	173	0.003	0.003	30,240	121	0.003	0.003	33,500	110	0.003	0.003
F695TX-R	0.15R×1	43,200	432	0.01	0.01	36,000	360	0.01	0.01	30,750	278	0.01	0.01	30,750	233	0.01	0.01
F695TX-R	0.15R×1.5	39,282	400	0.01	0.01	34,000	3,000	0.01	0.01	29,000	250	0.01	0.01	29,000	220	0.01	0.01
F695TX-R	0.15R×2	38,700	333	0.01	0.01	32,250	278	0.008	0.008	27,750	203	0.008	0.008	27,750	173	0.006	0.008
F695TX-R	0.15R×3	34,200	288	0.005	0.005	28,500	240	0.007	0.006	24,000	180	0.006	0.006	24,000	150	0.004	0.006
F695TX-R	0.2R×1	43,200	594	0.03	0.03	36,000	495	0.018	0.024	27,750	338	0.015	0.024	27,750	285	0.013	0.024
F695TX-R	0.2R×1.5	43,200	560	0.02	0.02	36,000	460	0.018	0.024	27,750	320	0.015	0.024	27,750	260	0.012	0.024
F695TX-R	0.2R×2	43,200	531	0.016	0.016	36,000	443	0.018	0.024	27,750	300	0.015	0.024	27,750	255	0.012	0.024
F695TX-R	0.2R×3	36,900	378	0.01	0.01	30,750	315	0.012	0.012	23,250	210	0.011	0.012	23,250	180	0.009	0.012
F695TX-R	0.2R×4	34,500	360	0.01	0.01	2,850	300	0.009	0.012	22,500	203	0.009	0.012	22,500	173	0.007	0.012
F695TX-R	0.2R×5	26,100	297	0.01	0.01	21,750	248	0.008	0.012	19,500	195	0.007	0.012	19,500	158	0.005	0.012
F695TX-R	0.25R×1/0.25R×2/0.25R×3	34,200	522	0.03	0.045	33,000	720	0.03	0.04	26,000	400	0.02	0.04	26,000	230	0.012	0.03
F695TX-R	0.25R×4	34,200	522	0.02	0.04	28,500	435	0.017	0.024	23,250	300	0.014	0.024	23,250	165	0.009	0.012
F695TX-R	0.25R×5	29,700	432	0.02	0.03	24,750	360	0.012	0.012	22,500	293	0.009	0.012	22,500	150	0.008	0.012
F695TX-R	0.25R×6	25,200	360	0.01	0.03	21,000	300	0.008	0.012	20,250	248	0.005	0.012	20,250	150	0.005	0.010
F695TX-R	0.25R×8	25,200	360	0.01	0.02	21,000	300	0.008	0.012	20,250	248	0.005	0.012	20,250	150	0.005	0.010
F695TX-R	0.25R×10	23,500	300	0.006	0.01	18,000	270	0.006	0.01	20,000	210	0.005	0.01	20,000	130	0.005	0.01
F695TX-R	0.3R×1/0.3R×2/0.3R×3	34,500	693	0.04	0.07	30,000	630	0.03	0.1	24,000	420	0.025	0.1	24,000	370	0.025	0.1
F695TX-R	0.3R×4/0.3R×5/0.3R×6	31,500	414	0.02	0.04	26,250	450	0.020	0.072	19,500	285	0.016	0.072	19,500	240	0.013	0.072
F695TX-R	0.3R×8	21,600	360	0.02	0.04	18,000	300	0.009	0.036	17,250	240	0.006	0.036	17,250	203	0.005	0.036
F695TX-R	0.3R×10	20,500	330	0.008	0.03	16,500	300	0.006	0.03	15,000	200	0.005	0.03	15,000	170	0.005	0.03
F695TX-R	0.3R×12	20,000	300	0.005	0.03	15,000	250	0.006	0.03	13,500	170	0.005	0.03	13,500	150	0.005	0.03
F695TX-R	0.5R×2/0.5R×3/0.5R×4	29,500	710	0.07	0.18	25,500	630	0.06	0.2	16,800	380	0.05	0.2	15,500	370	0.01	0.18
F695TX-R	0.5R×5/0.5R×6/0.5R×8	28,800	693	0.05	0.18	24,000	5,775	0.057	0.2	16,500	360	0.045	0.2	14,025	360	0.009	0.180
F695TX-R	0.5R×10	15,840	477	0.03	0.1	13,200	398	0.024	0.060	12,375	315	0.018	0.060	11,550	225	0.009	0.060
F695TX-R	0.5R×12	15,840	477	0.02	0.08	13,200	398	0.024	0.060	12,375	315	0.018	0.060	11,550	225	0.009	0.060
F695TX-R	0.5R×16	13,860	396	0.02	0.05	11,550	330	0.018	0.060	10,725	270	0.014	0.060	9,075	180	0.005	0.036
F695TX-R	0.5R×20	12,870	324	0.02	0.04	10,725	270	0.013	0.036	9,900	225	0.009	0.036	7,425	135	0.005	0.024
F695TX-R	0.5R×25	11,500	300	0.01	0.035	10,000	240	0.01	0.03	8,800	200	0.009	0.03	7,400	110	0.005	0.02
F695TX-R	0.75R×2/0.75R×4/0.75R×6	19,500	1,000	0.15	0.2	19,500	900	0.15	0.2	12,000	550	0.12	0.2	11,000	500	0.09	0.2
F695TX-R	0.75R×8/0.75R×10	14,670	630	0.1	0.155	12,225	525	0.084	0.180	9,075	338	0.069	0.180	9,075	300	0.057	0.180
F695TX-R	0.75R×12/0.75R×16	14,670	630	0.06	0.1	12,225	525	0.084	0.180	9,075	338	0.069	0.180	9,075	300	0.057	0.180
F695TX-R	0.75R×20	11,160	432	0.04	0.05	9,300	360	0.016	0.060	8,700	293	0.012	0.060	8,700	270	0.010	0.060
F695TX-R	0.75R×25	10,000	390	0.03	0.03	9,000	300	0.03	0.03	8,500	250	0.01	0.03	8,200	250	0.01	0.03
F695TX-R	0.75R×30	9,000	380	0.02	0.02	8,500	300	0.02	0.02	8,000	240	0.01	0.01	7,500	220	0.01	0.01
F695TX-R	1R×3/1R×4/1R×6/1R×8	17,000	1,200	0.2	0.2	14,500	1,000	0.2	0.2	10,000	850	0.15	0.2	10,000	650	0.08	0.2
F695TX-R	1R×10/1R×12/1R×16	16,650	1,008	0.05	0.15	13,875	840	0.05	0.15	9,900	653	0.05	0.15	9,900	533	0.03	0.15
F695TX-R	1R×20	13,230	522	0.05	0.05	11,025	435	0.05	0.05	8,700	435	0.05	0.05	8,700	360	0.05	0.05
F695TX-R	1R×30	9,540	405	0.03	0.03	7,950	338	0.03	0.03	7,650	338	0.03	0.03	7,650	270	0.03	0.03
F695TX-R	1R×40	9,100	300	0.02	0.02	7,200	280	0.02	0.02	7,200	260	0.01	0.01	6,800	230	0.01	0.01
F695TX-R	1.5R×6/1.5R×8/1.5R×10	11,610	1,512	0.15	0.2	9,675	1,260	0.1	0.2	6,900	975	0.15	0.2	4,800	533	0.15	0.2
F695TX-R	1.5R×12/1.5R×16	11,610	1,359	0.1	0.2	9,675	1,133	0.1	0.2	6,900	878	0.15	0.2	4,800	488	0.15	0.2
F695TX-R	1.5R×20	9,045	1,067	0.1	0.15	7,538	889	0.13	0.15	6,075	780	0.13	0.15	4,350	443	0.09	0.15
F695TX-R	1.5R×30	7,920	702	0.07	0.07	6,600	585	0.07	0.07	6,075	585	0.04	0.07	4,350	315	0.04	0.07
F695TX-R	1.5R×40	6,350	450	0.03	0.03	6,350	450	0.03	0.03	5,400	450	0.03	0.03	3,600	250	0.03	0.03
F695TX-R	2R×8/2R×10/2R×12	8,730	1,404	0.15	0.2	7,275	1,170	0.1	0.2	5,100	908	0.2	0.2	5,100	735	0.15	0.2
F695TX-R	2R×16/2R×20	8,730	1,287	0.13	0.2	7,275	1,073	0.1	0.2	5,100	833	0.2	0.2	5,100	660	0.15	0.2
F695TX-R	2R×30	7,560	1,125	0.1	0.15	6,300	938	0.1	0.16	4,500	735	0.15	0.15	4,500	585	0.15	0.15
F695TX-R	2R×40	5,940	855	0.08	0.1	4,950	713	0.07	0.15	4,500	735	0.1	0.15	4,500	585	0.1	0.15
F695TX-R	2R×50	5,310	423	0.05	0.1	4,425	353	0.05	0.1	4,200	368	0.05	0.1	4,200	293	0.050	0.05
F695TX-R	2.5R×10/2.5R×20	7644	764	0.15	0.3	7262	726	0.15	0.3	6899	690	0.15	0.2	6554	621	0.13	0.2
F695TX-R	2.5R×30	5733	570	0.1	0.2	5446	542	0.1	0.2	5174	514	0.1	0.15	4657	489	0.1	0.15
F695TX-R	2.5R×40	5415	550	0.08	0.15	5144	523	0.08	0.15	4887	496	0.05	0.15	4398	472	0.05	0.15
F695TX-R	2.5R×50	5096	500	0.08	0.1	4841	475	0.08	0.1	4599	451	0.05	0.1	4139	429	0.05	0.1
F695TX-R	3R×12/3R×20	5839	640	0.2	0.3	5547	608	0.2	0.3	5270	578	0.2	0.15	4743	549	0.2	0.1
F695TX-R	3R×30	4778	590	0.13	0.2	4539	561	0.13	0.2	4312	532	0.1	0.1	3881	506	0.1	0.2
F695TX-R	3R×40	4512	550	0.13	0.2	4286	523	0.13	0.2	4072	496	0.1	0.1	3665	472	0.1	0.2
F695TX-R	3R×50	4247	500	0.1	0.15	4034	475	0.1	0.15	3833	451	0.1	0.1	3449	429	0.05	0.15



F691TX

End Mills For Rib Processing

Code No. F691TX-Dc×L1

SMG
CarbideAlTiSiN
TX

Type of Operation



Work Material

P	H	M	K	N	S
●	●	●	○	○	○

P	Steel
---	-------

H	<38HRC Hardened Steel
---	--------------------------

H	<48HRC Hardened Steel
---	--------------------------

H	<56HRC Hardened Steel
---	--------------------------

H	<68HRC Hardened Steel
---	--------------------------

K	Cast Iron
---	-----------

N	Copper
---	--------

Feature of product:

End Mills For Rib Processing with Sharp Corner Edge- 2 Flutes Square

Widely used in high precision mold and deep machining angle clean with long neck.

Good wear resistance and lubricating effect with Nano multilayer coating.

Designed with sharp corner edge can accurately work on the right angle.

Available with complete size range.

Workable for various steel materials and copper electrode materials.



Sharp Corner edge
A-1

Dc	L1	Lc	L	d	D1	AlTiSiN F691TX
0 -0.02	mm	mm	mm	h5	mm	
0.5	2	0.7	50	4	0.45	●
0.5	4	0.7	50	4	0.45	●
0.5	6	0.7	50	4	0.45	●
0.6	2	0.9	50	4	0.55	●
0.6	4	0.9	50	4	0.55	●
0.6	6	0.9	50	4	0.55	●
0.7	2	1	50	4	0.65	●
0.7	4	1	50	4	0.65	●
0.7	6	1	50	4	0.65	●
0.8	4	1.2	50	4	0.75	●
0.8	6	1.2	50	4	0.75	●
0.8	8	1.2	50	4	0.75	●
1	6	1.5	50	4	0.95	●
1	8	1.5	50	4	0.95	●
1	10	1.5	50	4	0.95	●
1	12	1.5	50	4	0.95	●
1.2	6	1.8	50	4	1.15	●
1.2	10	1.8	50	4	1.15	●
1.5	6	2.3	50	4	1.45	●
1.5	8	2.3	50	4	1.45	●
1.5	10	2.3	50	4	1.45	●
1.5	12	2.3	50	4	1.45	●
1.5	14	2.3	50	4	1.45	●
1.5	16	2.3	50	4	1.45	●
1.5	20	2.3	60	4	1.45	●
2	6	3	50	4	1.95	●
2	8	3	50	4	1.95	●
2	10	3	50	4	1.95	●
2	12	3	50	4	1.95	●
2	14	3	50	4	1.95	●
2	16	3	50	4	1.95	●
2	20	3	60	4	1.95	●
2.5	8	3.7	50	4	2.4	●
2.5	10	3.7	50	4	2.4	●
2.5	12	3.7	50	4	2.4	●
2.5	16	3.7	60	4	2.4	●
3	12	4.5	50	6	2.85	●
3	14	4.5	60	6	2.85	●
3	16	4.5	60	6	2.85	●
3	18	4.5	60	6	2.85	●
3	20	4.5	60	6	2.85	●
3	25	4.5	70	6	2.85	●

Slotting













Work Material	Code No.	Dc×Ll	GR.1 Carbon Steel			GR.2 Low-alloyed Steel (~24HRC)			GR.3 Hi-alloyed Steel (~30HRC)			GR.4 Hardened Steel (30~38HRC)			GR.5 Hardened Steel (38~48HRC)			GR.6 Hardened Steel (48~56HRC)			GR.7 Hardened Steel (56~68HRC)		
			RPM (min-1)	Feed (mm/min)	ap (mm)	RPM (min-1)	Feed (mm/min)	ap (mm)	RPM (min-1)	Feed (mm/min)	ap (mm)	RPM (min-1)	Feed (mm/min)	ap (mm)	RPM (min-1)	Feed (mm/min)	ap (mm)	RPM (min-1)	Feed (mm/min)	ap (mm)	RPM (min-1)	Feed (mm/min)	ap (mm)
F691TX	0.5×2	45,440	720	0.015	45,440	720	0.015	43,200	608	0.014	32,480	408	0.011	32,480	408	0.011	26,000	280	0.008	14,000	20	0.008	
F691TX	0.5×4	32,480	464	0.008	32,480	464	0.008	28,880	368	0.007	23,760	264	0.006	23,760	264	0.006	18,960	184	0.004	14,000	18	0.004	
F691TX	0.5×6	26,720	336	0.004	26,720	336	0.004	22,800	256	0.004	19,760	200	0.003	19,760	200	0.003	15,760	136	0.002	14,000	16	0.002	
F691TX	0.6×2	50,880	992	0.023	50,880	992	0.023	42,640	744	0.02	31,280	480	0.016	31,280	480	0.016	25,040	328	0.011	12,000	23	0.011	
F691TX	0.6×4	33,040	592	0.012	33,040	592	0.012	27,760	440	0.011	22,320	312	0.009	22,320	312	0.009	17,840	216	0.006	12,000	21	0.006	
F691TX	0.6×6	25,680	416	0.007	25,680	416	0.007	21,600	312	0.006	18,400	232	0.005	18,400	232	0.005	14,720	160	0.003	12,000	19	0.003	
F691TX	0.7×2	31,120	700	0.02	31,120	700	0.02	26,160	510	0.02	20,640	360	0.02	20,640	360	0.02	16,480	240	0.01	10,000	20	0.01	
F691TX	0.7×4	31,120	672	0.017	31,120	672	0.017	26,160	504	0.015	20,640	352	0.012	20,640	352	0.012	16,480	232	0.009	10,000	22	0.009	
F691TX	0.7×6	24,160	480	0.01	24,160	480	0.01	20,320	360	0.009	16,960	264	0.007	16,960	264	0.007	13,520	184	0.005	10,000	20	0.005	
F691TX	0.8×4	29,680	744	0.027	29,680	744	0.027	24,880	560	0.024	19,280	384	0.019	19,280	384	0.019	15,440	264	0.013	8,000	20	0.013	
F691TX	0.8×6	23,040	544	0.015	23,040	544	0.015	19,360	408	0.013	15,840	296	0.01	15,840	296	0.01	12,640	200	0.007	8,000	18	0.007	
F691TX	0.8×8	19,280	416	0.009	19,280	416	0.009	16,240	312	0.008	13,760	240	0.006	13,760	240	0.006	11,040	160	0.004	8,000	16	0.004	
F691TX	1×6	21,200	680	0.023	21,200	680	0.023	17,680	504	0.021	14,080	352	0.016	14,080	352	0.016	11,280	248	0.012	6,500	14	0.012	
F691TX	1×8	17,680	528	0.014	17,680	528	0.014	14,880	392	0.013	12,240	288	0.01	12,240	288	0.01	9,840	200	0.01	6,500	14	0.01	
F691TX	1×10	15,360	424	0.01	15,360	424	0.01	12,960	320	0.009	11,040	240	0.007	11,040	240	0.007	8,800	168	0.005	6,500	12	0.005	
F691TX	1×12	13,760	352	0.007	13,760	352	0.007	11,600	264	0.006	10,080	200	0.005	10,080	200	0.005	8,080	136	0.003	6,500	11	0.003	
F691TX	1.2×6	19,840	776	0.037	19,840	776	0.037	16,560	576	0.034	12,880	392	0.026	12,880	392	0.026	10,240	272	0.019	9,600	22	0.019	
F691TX	1.2×10	14,400	496	0.016	14,400	496	0.016	12,080	376	0.014	9,920	272	0.011	9,920	272	0.011	7,920	184	0.008	/	/	0.008	
F691TX	1.5×6	18,240	896	0.057	18,240	896	0.057	15,200	672	0.051	11,520	440	0.04	11,520	440	0.04	9,200	304	0.028	9,600	60	0.028	
F691TX	1.5×8	15,200	720	0.041	15,200	720	0.041	12,720	536	0.037	10,000	368	0.029	10,000	368	0.029	8,000	256	0.02	9,600	25	0.02	
F691TX	1.5×10	13,280	600	0.03	13,280	600	0.03	11,040	448	0.027	8,960	312	0.021	8,960	312	0.021	7,120	216	0.015	9,600	13	0.015	
F691TX	1.5×12	11,840	504	0.023	11,840	504	0.023	9,920	376	0.02	8,160	272	0.016	8,160	272	0.016	6,560	192	0.011	/	/	0.011	
F691TX	1.5×14	10,720	440	0.017	10,720	440	0.017	8,960	328	0.016	7,600	240	0.012	7,600	240	0.012	6,080	168	0.009	/	/	0.009	
F691TX	1.5×16	9,840	384	0.013	9,840	384	0.013	8,240	288	0.012	7,120	216	0.009	7,120	216	0.009	5,680	152	0.007	/	/	0.007	
F691TX	1.5×20	8,560	296	0.009	8,560	296	0.009	7,200	224	0.008	6,320	160	0.006	6,320	160	0.006	5,040	120	0.004	/	/	0.004	
F691TX	2×6	16,240	1,080	0.064	16,240	1,080	0.064	13,920	824	0.058	10,000	520	0.045	10,000	520	0.045	8,000	360	0.032	9,600	211	0.032	
F691TX	2×8	13,600	872	0.054	13,600	872	0.054	11,600	664	0.048	8,640	432	0.038	8,640	432	0.038	6,960	304	0.027	9,600	89	0.027	
F691TX	2×10	11,840	736	0.045	11,840	736	0.045	10,080	560	0.04	7,760	376	0.031	7,760	376	0.031	6,240	264	0.022	9,600	45	0.022	
F691TX	2×12	10,560	632	0.037	10,560	632	0.037	8,960	480	0.034	7,120	336	0.026	7,120	336	0.026	5,680	232	0.019	9,600	56	0.019	
F691TX	2×14	9,600	560	0.031	9,600	560	0.031	8,160	424	0.028	6,560	296	0.022	6,560	296	0.022	5,280	208	0.016	9,600	16	0.016	
F691TX	2×16	8,880	496	0.026	8,880	496	0.026	7,520	376	0.024	6,160	272	0.018	6,160	272	0.018	4,880	184	0.013	9,600	11	0.013	
F691TX	2×20	7,680	400	0.018	7,680	400	0.018	6,480	304	0.016	5,520	224	0.013	5,520	224	0.013	4,400	152	0.009	/	/	0.009	
F691TX	2.5×8	12,000	1,072	0.077	12,000	1,072	0.077	10,240	816	0.069	7,680	536	0.054	7,680	536	0.054	6,160	368	0.039	9,600	227	0.039	
F691TX	2.5×10	10,480	912	0.068	10,480	912	0.068	8,880	688	0.061	6,880	472	0.048	6,880	472	0.048	5,520	320	0.034	9,600	116	0.034	
F691TX	2.5×12	9,440	800	0.06	9,440	800	0.06	8,000	600	0.054	6,320	416	0.042	6,320	416	0.042	5,040	288	0.03	9,600	67	0.03	
F691TX	2.5×16	7,920	632	0.045	7,920	632	0.045	6,720	472	0.04	5,440	344	0.031	5,440	344	0.031	4,400	232	0.022	9,600	28	0.022	
F691TX	3×12	8,400	888	0.081	8,400	888	0.081	6,960	664	0.073	5,360	448	0.057	5,360	448	0.057	4,240	304	0.041	8,000	128	0.041	
F691TX	3×14	7,680	800	0.072	7,680	800	0.072	6,400	592	0.065	4,960	408	0.051	4,960	408	0.051	4,000	280	0.036	8,000	81	0.036	
F691TX	3×16	7,120	720	0.064	7,120	720	0.064	5,920	536	0.058	4,720	376	0.045	4,720	376	0.045	3,760	256	0.032	8,000	54	0.032	
F691TX	3×18	6,640	656	0.057	6,640	656	0.057	5,600	488	0.051	4,480	344	0.04	4,480	344	0.04	3,600	240	0.028	8,000	38	0.028	
F691TX	3×20	6,240	600	0.05	6,240	600	0.05	5,280	448	0.045	4,240	320	0.035	4,240	320	0.035	3,440	224	0.025	8,000	27	0.025	
F691TX	3×25	5,520	496	0.036	5,520	496	0.036	4,640	368	0.032	3,840	272	0.025	3,840	272	0.025	3,120	184	0.018	8,000	14	0.018	

(mm)



1. Please work with good rigidity / high precision facilities and collet chuck.
2. Please choose proper cutting fluid.
3. The cutting data is reference value only. Please adjust it according to your real working conditions.
4. If RPM is lower the reference value, the Feed rate (fz) and RPM should be reduced by the same proportion.
5. If vibration occurs during cutting, please reduce cutting parameter.

End Mills For Graphite

	Page	167	169	171	173
Apperance					
Code No		G696DC	G234DC G244DC	G697DC	G298DC
Carbide		MG Carbide	MG Carbide	MG Carbide	MG Carbide
Coating		Diamond DC	Diamond DC	Diamond DC	Diamond DC
Helix Angle		 30°	 30°	 30°	 30°
No.of Flutes		 2	 2	 2	 4

ASIA

G696DC

Ball Nose End Mills For Graphite

Code No. G696DC-R×L1

MG
CarbideDiamond
DC

Type of Operation



Work Material

P	H	M	K	N	S
				●	

N Graphite

Feature of product:

Ball Nose End Mills for Graphite
Apply with high hardness diamond coating and have a good wear resistance.

Keep lower wear condition level in high speed processing.

Suitable for corner angle cleaning processing of graphite electrodes.

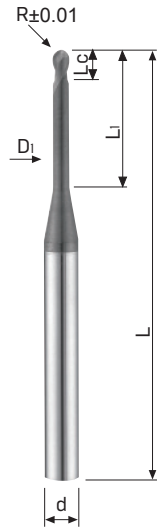

R ±0.01	L1 mm	Lc mm	L mm	d h5	D1 mm	Diamond G696DC
0.2R	5	0.6	50	4	0.37	●
0.2R	10	0.6	50	4	0.37	●
0.3R	5	0.9	50	4	0.55	●
0.3R	10	0.9	50	4	0.55	●
0.3R	15	0.9	60	4	0.55	●
0.3R	20	0.9	60	4	0.55	●
0.5R	5	1.5	50	4	0.95	●
0.5R	10	1.5	50	4	0.95	●
0.5R	15	1.5	60	4	0.95	●
0.5R	20	1.5	60	4	0.95	●
0.5R	30	1.5	80	4	0.95	●
0.75R	5	2.3	60	4	1.45	●
0.75R	10	2.3	60	4	1.45	●
0.75R	15	2.3	60	4	1.45	●
0.75R	20	2.3	60	4	1.45	●
0.75R	30	2.3	80	4	1.45	●
0.75R	40	2.3	80	4	1.45	●
1R	5	3	60	4	1.95	●
1R	10	3	60	4	1.95	●
1R	15	3	60	4	1.95	●
1R	20	3	60	4	1.95	●
1R	30	3	80	4	1.95	●
1R	40	3	80	4	1.95	●
1R	60	3	100	4	1.95	●
1.5R	10	4.5	60	4	2.85	●
1.5R	20	4.5	60	4	2.85	●
1.5R	40	4.5	80	4	2.85	●
1.5R	60	4.5	100	4	2.85	●
2R	20	6	60	4	3.85	●
2R	40	6	80	4	3.85	●
2R	60	6	120	4	3.85	●

High-speed machining

Work Material		GR.14 Graphite		
Code No.	R×LI	RPM (min-1)	Feed (mm/min)	AP (mm)
G696DC-0.2R	0.2R×5	38000~20000	850~480	0.03
G696DC-0.2R	0.2R×10	30000~18000	430~250	0.03
G696DC-0.3R	0.3R×5	38000~20000	960~480	0.06
G696DC-0.3R	0.3R×10	30000~20000	580~385	0.05
G696DC-0.3R	0.3R×15	15000~10000	215~145	0.03
G696DC-0.3R	0.3R×20	8000~7000	115~95	0.03
G696DC-0.5R	0.5R×5	38000~20000	1080~600	0.1
G696DC-0.5R	0.5R×10	30000~20000	840~575	0.1
G696DC-0.5R	0.5R×15	23000~18000	530~410	0.08
G696DC-0.5R	0.5R×20	16000~12000	270~205	0.08
G696DC-0.5R	0.5R×30	8000~5000	145~85	0.04
G696DC-0.75R	0.75R×5	38000~20000	1700~900	0.15
G696DC-0.75R	0.75R×10	36000~20000	1440~865	0.15
G696DC-0.75R	0.75R×15	30000~20000	1300~865	0.15
G696DC-0.75R	0.75R×20	20000~18000	670~625	0.15
G696DC-0.75R	0.75R×30	11500~9000	295~240	0.1
G696DC-0.75R	0.75R×40	7000~5000	190~130	0.075
G696DC-1R	1R×5	38000~20000	2650~1350	0.2
G696DC-1R	1R×10	38000~20000	2250~1350	0.2
G696DC-1R	1R×15	28000~20000	1800~1350	0.2
G696DC-1R	1R×20	21800~18000	1470~1100	0.2
G696DC-1R	1R×30	15200~11500	800~615	0.18
G696DC-1R	1R×40	5700~4000	315~210	0.13
G696DC-1R	1R×60	5700~4000	315~210	0.08
G696DC-1.5R	1.5R×10	36000~20000	2400~1350	0.3
G696DC-1.5R	1.5R×20	19000~15500	1945~1550	0.3
G696DC-1.5R	1.5R×40	11875~9200	950~740	0.22
G696DC-1.5R	1.5R×60	6650~4000	465~280	0.15
G696DC-2R	2R×20	19000~14000	2800~2050	0.4
G696DC-2R	2R×40	11000~9500	1615~1350	0.4
G696DC-2R	2R×60	7800~5700	1120~770	0.3

1. Please work with good rigidity / high precision facilities and collet chuck.
2. Please choose proper cutting fluid.
3. The cutting data is reference value only. Please adjust it according to your real working conditions.
4. If RPM is lower the reference value, the Feed rate (fz) and RPM should be reduced by the same proportion.
5. If vibration occurs during cutting, please reduce cutting parameter.

G234DC / G244DC

Ball Nose End Mills For Graphite

MG Carbide **Diamond DC**



Type of Operation



Work Material

P	H	M	K	N	S
				●	

N Graphite

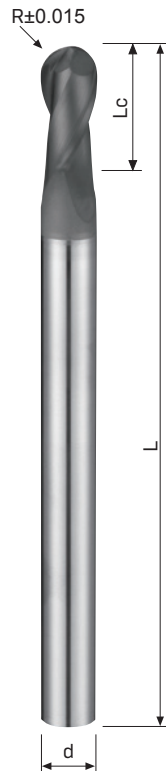

Code No. G234DC-Dc

Dc	R	Lc	L	d	Diamond
$\begin{matrix} 0 \\ -0.03 \end{matrix}$	± 0.015	mm	mm	h6	G234DC
4	2R	8	80	4	●
6	3R	12	80	6	●
8	4R	16	100	8	●
10	5R	20	100	10	●
12	6R	24	110	12	●

Feature of product:

Ball Nose End Mills for Graphite-Long Length

Apply with high hardness diamond coating and have a good wear resistance.

Keep lower wear condition level in high speed processing.

Application for curved surface and round groove processing of graphite.



Code No. G244DC-Dc

Dc	R	Lc	L	d	Diamond
$\begin{matrix} 0 \\ -0.03 \end{matrix}$	± 0.015	mm	mm	h6	G244DC
4	2R	20	120	4	●
6	3R	30	120	6	●
8	4R	40	160	8	●
10	5R	50	180	10	●
12	6R	60	200	12	●

Roughing

Work Material		GR.I4 Graphite		
Code No.	Dc	RPM [min-1]	Feed [mm/min]	AP (mm)
G234DC/G244DC-R2	4	19000~11000	2900~1800	0.40
G234DC/G244DC-R3	6	19000~9600	4000~2100	0.60
G234DC/G244DC-R4	8	15200~7200	3700~1800	0.80
G234DC/G244DC-R5	10	11875~5700	2750~1350	1.00
G234DC/G244DC-R6	12	9975~4800	2400~1100	1.20

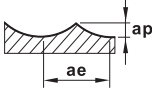

Finishing

Work Material		GR.I4 Graphite		
Code No.	Dc	RPM [min-1]	Feed [mm/min]	AP (mm)
G234DC/G244DC-R2	4	19000~11000	1900~1200	0.12
G234DC/G244DC-R3	6	19000~9600	2800~1400	0.18
G234DC/G244DC-R4	8	15200~7200	2400~1200	0.22
G234DC/G244DC-R5	10	11875~5700	1800~900	0.25
G234DC/G244DC-R6	12	9975~4800	1600~750	0.30

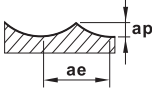

※ Notice: G244DC is Long Length series End Mills. Please adjust the parameter according.

1. Please work with good rigidity / high precision facilities and collet chuck.
2. Please choose proper cutting fluid.
3. The cutting data is reference value only. Please adjust it according to your real working conditions.
4. If RPM is lower the reference value, the Feed rate (fz) and RPM should be reduced by the same proportion.
5. If vibration occurs during cutting, please reduce cutting parameter.

G697DC

End Mills For Graphite

MG
CarbideDiamond
DC

Type of Operation



Work Material

P	H	M	K	N	S
				●	

N Graphite

Feature of product:

End Mills for Graphite

Apply with high hardness diamond coating and have a good wear resistance.

Keep lower wear condition level in high speed processing.

Suitable for corner angle cleaning processing of graphite electrodes.



Code No. G697DC-Dc×R×L1

Dc 0 -0.02	R ±0.01	L1 mm	Lc mm	L mm	d h5	D1 mm	Diamond G697DC
0.5	R0.1	5	0.9	50	4	0.45	●
0.5	R0.1	10	0.9	50	4	0.45	●
0.5	R0.1	15	0.9	60	4	0.45	●
0.5	R0.1	20	0.9	60	4	0.45	●
1	R0.2	5	1.5	50	4	0.95	●
1	R0.2	10	1.5	50	4	0.95	●
1	R0.2	15	1.5	60	4	0.95	●
1	R0.2	20	1.5	60	4	0.95	●
1	R0.2	30	1.5	80	4	0.95	●
1.5	R0.2	5	2.3	60	4	1.45	●
1.5	R0.2	10	2.3	60	4	1.45	●
1.5	R0.2	15	2.3	60	4	1.45	●
1.5	R0.2	20	2.3	60	4	1.45	●
1.5	R0.2	30	2.3	80	4	1.45	●
1.5	R0.2	40	2.3	80	4	1.45	●
2	R0.2	5	3	60	4	1.95	●
2	R0.2	10	3	60	4	1.95	●
2	R0.2	15	3	60	4	1.95	●
2	R0.2	20	3	60	4	1.95	●
2	R0.2	30	3	80	4	1.95	●
2	R0.2	40	3	80	4	1.95	●
2	R0.2	60	3	100	4	1.95	●
3	R0.2	10	4.5	60	4	2.85	●
3	R0.2	20	4.5	60	4	2.85	●
3	R0.2	40	4.5	80	4	2.85	●
3	R0.2	60	4.5	100	4	2.85	●
4	R0.2	20	6	60	4	3.85	●
4	R0.2	40	6	80	4	3.85	●
4	R0.2	60	6	120	4	3.85	●

High-speed machining

Work Material		GR.14 Graphite			
Code No.	Dc×Ll	RPM (min ⁻¹)	Feed (mm/min)	AP (mm)	AE (mm)
G697DC	0.5×5	19000~16000	684~575	0.05	0.24
G697DC	0.5×10	15200~12000	540~500	0.04	0.24
G697DC	0.5×15	10400~9000	375~325	0.03	0.12
G697DC	0.5×20	10200~8000	375~290	0.03	0.09
G697DC	1×5	15200~12000	1080~865	0.12	0.45
G697DC	1×10	15200~12000	1080~865	0.1	0.45
G697DC	1×15	13300~11000	950~790	0.1	0.43
G697DC	1×20	11000~8000	820~575	0.1	0.4
G697DC	1×30	8500~700	615~505	0.08	0.35
G697DC	1.5×5	15200~13000	1300~1100	0.17	0.85
G697DC	1.5×10	15200~13000	1300~1100	0.12	0.85
G697DC	1.5×15	13300~11000	1140~925	0.1	0.85
G697DC	1.5×20	12000~10000	1020~850	0.1	0.85
G697DC	1.5×30	11400~8000	950~670	0.08	0.85
G697DC	1.5×40	9500~7000	870~590	0.08	0.7
G697DC	2×5	15200~12000	1900~1500	0.3	1.25
G697DC	2×10	15200~12000	1900~1500	0.3	1.25
G697DC	2×15	12300~9000	1500~1150	0.2	1.25
G697DC	2×20	104500~8000	1330~1000	0.18	1.2
G697DC	2×30	9000~7000	1080~850	0.13	0.8
G697DC	2×40	7600~6000	950~755	0.13	0.8
G697DC	2×60	5700~4000	715~505	0.07	0.6
G697DC	3×10	15200~12000	2300~1850	0.35	2.0
G697DC	3×20	13300~10000	2040~1550	0.3	2.0
G697DC	3×40	11400~8000	1750~1250	0.2	1.8
G697DC	3×60	6650~4000	1045~615	0.15	1.6
G697DC	4×20	12000~8500	3250~2300	0.35	2.8
G697DC	4×40	11400~8000	2950~2100	0.35	2.8
G697DC	4×60	5700~3000	1615~855	0.2	2.0

1. Please work with good rigidity / high precision facilities and collet chuck.
2. Please choose proper cutting fluid.
3. The cutting data is reference value only. Please adjust it according to your real working conditions.
4. If RPM is lower the reference value, the Feed rate (fz) and RPM should be reduced by the same proportion.
5. If vibration occurs during cutting, please reduce cutting parameter.

G298DC

End Mills For Graphite

MG
CarbideDiamond
DC

Type of Operation



Work Material



N Graphite

Feature of product:

End Mills for Graphite- Long Length

Apply with high hardness diamond coating and have a good wear resistance.

Keep lower wear condition level in high speed processing.

Application for graphite cutting.



Code No. G298DC-Dc×R×L1















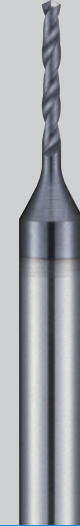



Dc 0 -0.03	R ±0.01	L1 mm	Lc mm	L mm	d h5	D1 mm	Diamond G298DC
4	R0.5	20	8	80	4	3.85	●
6	R0.5	30	12	100	6	5.7	●
8	R0.5	40	16	120	8	7.6	●
10	R0.5	50	20	140	10	9.5	●
12	R0.5	60	24	160	12	11.4	●

Ordinary cutting

Work Material		GR.14 Graphite			
Code No.	Dc	RPM (min-1)	Feed (mm/min)	AP (mm)	AE (mm)
G298DC-4	4	12000~8000	2450~1650	0.08	1.00
G298DC-6	6	12000~7000	3050~1800	0.20	2.00
G298DC-8	8	10000~7000	2700~1900	0.20	2.80
G298DC-10	10	8000~4000	2200~1100	0.20	4.40
G298DC-12	12	6000~3000	1650~815	0.20	4.40

1. Please work with good rigidity / high precision facilities and collet chuck.
2. Please choose proper cutting fluid.
3. The cutting data is reference value only. Please adjust it according to your real working conditions.
4. If RPM is lower the reference value, the Feed rate (fz) and RPM should be reduced by the same proportion.
5. If vibration occurs during cutting, please reduce cutting parameter.

Drills

Page	177	179	181	185	189	193
Appearance						
Code No	D921X D922X D932X	D923X D924X	D420HX-3	D420HX-5	D420HX-8	D421TX
Carbide	MG Carbide	MG Carbide	MG Carbide	MG Carbide	MG Carbide	MG Carbide
Coating	AlTiN X-NaNo	AlTiN X-NaNo	AlTiCrN HX	AlTiCrN HX	AlTiCrN HX	AlTiSiN TX
Helix Angle	 D	 D	 30° 3XD	 30° 5XD	 30° 8XD	 3XD
No.of Flutes	 2	 2	 2	 2	 2	 2

ASIA

195 197 199 201 203 205 207

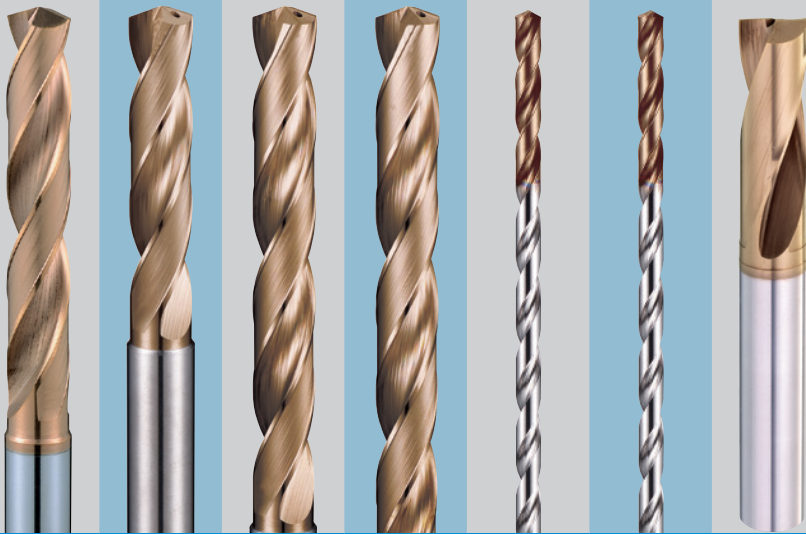

D422TX D423TX-3 D423TX-5 D423TX-8 D423TX-12
D423TX-16 D423TX-20
D423TX-25 D423TX-30 D425TX-2

MG Carbide MG Carbide MG Carbide MG Carbide MG Carbide MG Carbide MG Carbide

AlTiSiN TX AlTiSiN TX AlTiSiN TX AlTiSiN TX AlTiSiN TX AlTiSiN TX AlTiSiN TX



D921X / D922X / D932X

NC Spot Drills

MG
Carbide

AlTiN
X-NaNo

Work Material

P	H	M	K	N	S
●	●	○	●	○	○

P Steel

H <38HRC
Hardened Steel

H <48HRC
Hardened Steel

M Stainless Steel

K Cast Iron

N Copper

S Titanium

S Nickel

S High Temp Alloys

Feature of product:

D921X NC Spot Drills 60°

D922X NC Spot Drills 90°

D932X NC Spot Drills 90°- Long Length

Design with double drill tip angle to enhance the strength of drill tip.

Apply with AlTiN coating to increase wear resistance and improved tool life.

Application for spot drilling in different steels.

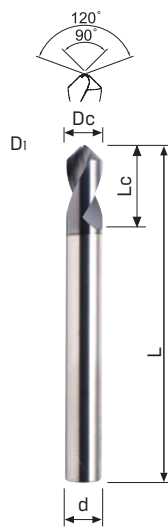
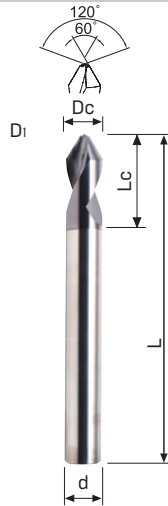

Code No. D921X-DC

Dc h6	Lc mm	L mm	d h6	D1 mm	60° D921X
0.5	1	38	3	0.15	●
1	2	38	3	0.3	●
2	4	38	3	0.6	●
3	6	50	3	1.0	●
4	8	50	4	1.5	●
6	12	70	6	2.0	●
8	16	80	8	2.5	●
10	20	90	10	3.0	●
12	24	110	12	4.0	●
16	32	120	16	5.0	●
20	40	130	20	6.0	●



Code No. D922X-DC

Dc h6	Lc mm	L mm	d h6	D1 mm	90° D922X
0.5	1	38	3	0.15	●
1	2	38	3	0.3	●
2	4	38	3	0.6	●
3	6	50	3	1.0	●
4	8	50	4	1.5	●
6	12	70	6	2.0	●
8	16	80	8	2.5	●
10	20	90	10	3.0	●
12	24	110	12	4.0	●
16	32	120	16	5.0	●
20	40	130	20	6.0	●



Code No. D932X-DC

Dc h6	Lc mm	L mm	d h6	D1 mm	90° D932X
3	9	75	3	1	●
4	12	100	4	1.5	●
6	15	150	6	2	●
8	20	150	8	2.5	●
10	25	200	10	3	●
12	30	200	12	4	●
16	40	250	16	5	●
20	45	250	20	6	●

Borehole parameters

Work Material		GR.1 Carbon Steel		GR.2 Low-alloyed Steel (~24HRC)		GR.3 Hi-alloyed Steel (~30HRC)		GR.4 Hardened Steel (30~38HRC)		GR.5 Hardened Steel (38~48HRC)		GR.9 Cast Iron	
Vc m/min		40~85		40~85		40~85		20~30		15~25		65~100	
Code No.	Dc	RPM (min-1)	Feed (mm/rev)	RPM (min-1)	Feed (mm/rev)	RPM (min-1)	Feed (mm/rev)	RPM (min-1)	Feed (mm/rev)	RPM (min-1)	Feed (mm/rev)	RPM (min-1)	Feed (mm/rev)
D921X/D922X-0.5	0.5	20,000	0.003~0.02	20,000	0.003~0.02	20,000	0.003~0.02	15,000	0.003~0.02	9,000	0.003~0.02	-	-
D921X/D922X-1	1	10,000	0.01~0.04	10,000	0.01~0.04	10,000	0.01~0.04	7,500	0.01~0.04	4,500	0.01~0.04	20,000	0.01~0.035
D921X/D922X-2	2	5,000	0.03~0.07	5,000	0.03~0.07	5,000	0.03~0.07	3,800	0.03~0.07	2,200	0.03~0.07	12,000	0.03~0.063
D921X/D922X/D932X-3	3	7,500	0.04~0.085	7,500	0.04~0.085	7,500	0.04~0.085	2,500	0.04~0.085	1,500	0.04~0.085	8,000	0.05~0.095
D921X/D922X/D932X-4	4	5,700	0.05~0.12	5,700	0.05~0.12	5,700	0.05~0.12	1,900	0.05~0.12	1,100	0.05~0.12	6,500	0.07~0.15
D921X/D922X/D932X-6	6	3,800	0.06~0.13	3,800	0.06~0.13	3,800	0.06~0.13	1,300	0.06~0.13	750	0.06~0.13	4,300	0.12~0.2
D921X/D922X/D932X-8	8	2,800	0.08~0.16	2,800	0.08~0.16	2,800	0.08~0.16	1,000	0.08~0.16	550	0.08~0.16	3,200	0.15~0.2
D921X/D922X/D932X-10	10	2,300	0.1~0.2	2,300	0.1~0.2	2,300	0.1~0.2	750	0.1~0.2	450	0.1~0.2	2,600	0.1~0.25
D921X/D922X/D932X-12	12	1,900	0.15~0.25	1,900	0.15~0.25	1,900	0.15~0.25	650	0.15~0.25	370	0.15~0.25	2,200	0.2~0.3
D921X/D922X/D932X-16	16	1,400	0.15~0.3	1,400	0.15~0.3	1,400	0.15~0.3	480	0.15~0.3	280	0.15~0.3	1,600	0.25~0.35
D921X/D922X/D932X-20	20	1,150	0.18~0.35	1,150	0.18~0.35	1,150	0.18~0.35	380	0.18~0.35	220	0.18~0.35	1,300	0.28~0.4

1. Please work with good rigidity / high precision facilities and collet chuck.
2. Please choose proper cutting fluid.
3. The cutting data is reference value only. Please adjust it according to your real working conditions.
4. If RPM is lower the reference value, the Feed rate [fz] and RPM should be reduced by the same proportion.
5. If vibration occurs during cutting, please reduce cutting parameter.

D923X / D924X

NC Spot Drills

MG
Carbide

AlTiN
X-NaNo

Work Material

P	H	M	K	N	S
●	●	○	●	○	○

P Steel

H <38HRC
Hardened Steel

H <48HRC
Hardened Steel

M Stainless Steel

K Cast Iron

N Copper

S Titanium

S Nickel

S High Temp Alloys

Feature of product:

D923X NC Spot Drills 120°

D924X NC Spot Drills 142°

Design with double drill tip angle to enhance the strength of drill tip.

Apply with AlTiN coating to increase wear resistance and improved tool life.

Application for spot drilling in different steels.

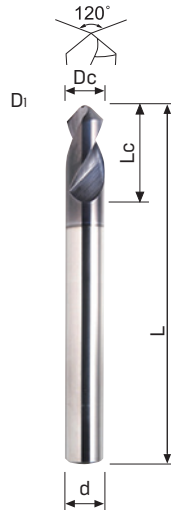

Code No. D923X-DC

Dc h6	Lc mm	L mm	d h6	120° D923X
0.5	1	38	3	●
1	2	38	3	●
2	4	38	3	●
3	6	50	3	●
4	8	50	4	●
6	12	70	6	●
8	16	80	8	●
10	20	90	10	●
12	24	110	12	●
16	32	120	16	●
20	40	130	20	●

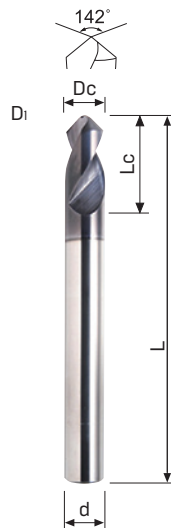

Code No. D924X-DC

Dc h6	Lc mm	L mm	d h6	142° D924X
0.5	1	38	3	●
1	2	38	3	●
2	4	38	3	●
3	6	50	3	●
4	8	50	4	●
6	12	70	6	●
8	16	80	8	●
10	20	90	10	●
12	24	110	12	●
16	32	120	16	●
20	40	130	20	●

Borehole parameters

Work Material		GR.1 Carbon Steel		GR.2 Low-alloyed Steel (~24HRC)		GR.3 Hi-alloyed Steel (~30HRC)		GR.4 Hardened Steel (30~38HRC)		GR.5 Hardened Steel (38~48HRC)		GR.9 Cast Iron	
Vc m/min		40~85		40~85		40~85		20~30		15~25		65~100	
Code No.	Dc	RPM (min-1)	Feed (mm/rev)	RPM (min-1)	Feed (mm/rev)	RPM (min-1)	Feed (mm/rev)	RPM (min-1)	Feed (mm/rev)	RPM (min-1)	Feed (mm/rev)	RPM (min-1)	Feed (mm/rev)
D923X/D924X-0.5	0.5	20,000	0.003~0.02	20,000	0.003~0.02	20,000	0.003~0.02	15,000	0.003~0.02	9,000	0.003~0.02	-	-
D923X/D924X-1	1	10,000	0.01~0.04	10,000	0.01~0.04	10,000	0.01~0.04	7,500	0.01~0.04	4,500	0.01~0.04	20,000	0.01~0.035
D923X/D924X-2	2	5,000	0.03~0.07	5,000	0.03~0.07	5,000	0.03~0.07	3,800	0.03~0.07	2,200	0.03~0.07	12,000	0.03~0.063
D923X/D924X-3	3	7,500	0.04~0.085	7,500	0.04~0.085	7,500	0.04~0.085	2,500	0.04~0.085	1,500	0.04~0.085	8,000	0.05~0.095
D923X/D924X-4	4	5,700	0.05~0.12	5,700	0.05~0.12	5,700	0.05~0.12	1,900	0.05~0.12	1,100	0.05~0.12	6,500	0.07~0.15
D923X/D924X-6	6	3,800	0.06~0.13	3,800	0.06~0.13	3,800	0.06~0.13	1,300	0.06~0.13	750	0.06~0.13	4,300	0.12~0.2
D923X/D924X-8	8	2,800	0.08~0.16	2,800	0.08~0.16	2,800	0.08~0.16	1,000	0.08~0.16	550	0.08~0.16	3,200	0.15~0.2
D923X/D924X-10	10	2,300	0.1~0.2	2,300	0.1~0.2	2,300	0.1~0.2	750	0.1~0.2	450	0.1~0.2	2,600	0.1~0.25
D923X/D924X-12	12	1,900	0.15~0.25	1,900	0.15~0.25	1,900	0.15~0.25	650	0.15~0.25	370	0.15~0.25	2,200	0.2~0.3
D923X/D924X-16	16	1,400	0.15~0.3	1,400	0.15~0.3	1,400	0.15~0.3	480	0.15~0.3	280	0.15~0.3	1,600	0.25~0.35
D923X/D924X-20	20	1,150	0.18~0.35	1,150	0.18~0.35	1,150	0.18~0.35	380	0.18~0.35	220	0.18~0.35	1,300	0.28~0.4

1. Please work with good rigidity / high precision facilities and collet chuck.
2. Please choose proper cutting fluid.
3. The cutting data is reference value only. Please adjust it according to your real working conditions.
4. If RPM is lower the reference value, the Feed rate [fz] and RPM should be reduced by the same proportion.
5. If vibration occurs during cutting, please reduce cutting parameter.

D420HX-3

Micro Precision Drills

MG
Carbide

AlTiCrN
HX

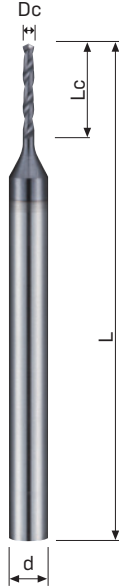

Code No. D420HX-3-DC

Work Material

P	H	M	K	N	S
●		●	●	●	

P Steel

M Stainless Steel

K Cast Iron

N Aluminium

N Copper

N Plastics

Feature of product:

Micro Precision Drills
 140° X-shape drill tip design which included sharp and strength.
 Dc. range from 0.1 to 2.0mm with every 0.01mm as size range.
 Good wear resistance and lubrication with Nano multilayer coating.
 Suitable for drilling application with Steels which is below HRC30, Stainless Steels, Cast Iron, Aluminium, Copper...etc.

Dc						Dc						Dc					
Dc	Lc	L	d	AlTiCrN	D420HX-3	Dc	Lc	L	d	AlTiCrN	D420HX-3	Dc	Lc	L	d	AlTiCrN	D420HX-3
-0.005	mm	mm	h6	D420HX-3		-0.005	mm	mm	h6	D420HX-3		-0.005	mm	mm	h6	D420HX-3	
0.1	0.6	38	3	●		0.7	4.5	38	3	●		1.3	8	42	3	●	
0.11	0.6	38	3	●		0.71	4.5	38	3	●		1.31	8	42	3	●	
0.12	0.8	38	3	●		0.72	4.5	38	3	●		1.32	8	42	3	●	
0.13	0.8	38	3	●		0.73	4.5	38	3	●		1.33	9	42	3	●	
0.14	0.8	38	3	●		0.74	4.5	38	3	●		1.34	9	42	3	●	
0.15	1	38	3	●		0.75	4.5	38	3	●		1.35	9	42	3	●	
0.16	1	38	3	●		0.76	5	38	3	●		1.36	9	42	3	●	
0.17	1	38	3	●		0.77	5	38	3	●		1.37	9	42	3	●	
0.18	1.2	38	3	●		0.78	5	38	3	●		1.38	9	42	3	●	
0.19	1.2	38	3	●		0.79	5	38	3	●		1.39	9	42	3	●	
0.2	1.5	38	3	●		0.8	5	38	3	●		1.4	9	42	3	●	
0.21	1.5	38	3	●		0.81	5	38	3	●		1.41	9	42	3	●	
0.22	1.5	38	3	●		0.82	5	38	3	●		1.42	9	42	3	●	
0.23	1.5	38	3	●		0.83	5	38	3	●		1.43	9	42	3	●	
0.24	1.5	38	3	●		0.84	5	38	3	●		1.44	9	42	3	●	
0.25	1.5	38	3	●		0.85	5	38	3	●		1.45	9	42	3	●	
0.26	1.5	38	3	●		0.86	5.5	38	3	●		1.46	9	42	3	●	
0.27	1.5	38	3	●		0.87	5.5	38	3	●		1.47	9	42	3	●	
0.28	1.5	38	3	●		0.88	5.5	38	3	●		1.48	9	42	3	●	
0.29	1.5	38	3	●		0.89	5.5	38	3	●		1.49	9	42	3	●	
0.3	1.5	38	3	●		0.9	5.5	38	3	●		1.5	9	42	3	●	
0.31	2	38	3	●		0.91	5.5	38	3	●		1.51	10	42	3	●	
0.32	2	38	3	●		0.92	5.5	38	3	●		1.52	10	42	3	●	
0.33	2	38	3	●		0.93	5.5	38	3	●		1.53	10	42	3	●	
0.34	2	38	3	●		0.94	5.5	38	3	●		1.54	10	42	3	●	
0.35	2	38	3	●		0.95	5.5	38	3	●		1.55	10	42	3	●	
0.36	2	38	3	●		0.96	6	38	3	●		1.56	10	42	3	●	
0.37	2	38	3	●		0.97	6	38	3	●		1.57	10	42	3	●	
0.38	2	38	3	●		0.98	6	38	3	●		1.58	10	42	3	●	
0.39	2.5	38	3	●		0.99	6	38	3	●		1.59	10	42	3	●	
0.4	2.5	38	3	●		1	6	38	3	●		1.6	10	42	3	●	
0.41	2.5	38	3	●		1.01	6	38	3	●		1.61	10	42	3	●	
0.42	2.5	38	3	●		1.02	6	38	3	●		1.62	10	42	3	●	
0.43	2.5	38	3	●		1.03	6	38	3	●		1.63	10	42	3	●	
0.44	2.5	38	3	●		1.04	6	38	3	●		1.64	10	42	3	●	
0.45	2.5	38	3	●		1.05	6	38	3	●		1.65	10	42	3	●	
0.46	2.5	38	3	●		1.06	6	38	3	●		1.66	10	42	3	●	
0.47	2.5	38	3	●		1.07	7	42	3	●		1.67	10	42	3	●	
0.48	2.5	38	3	●		1.08	7	42	3	●		1.68	10	42	3	●	
0.49	3	38	3	●		1.09	7	42	3	●		1.69	10	42	3	●	
0.5	3	38	3	●		1.1	7	42	3	●		1.7	10	42	3	●	
0.51	3	38	3	●		1.11	7	42	3	●		1.71	11	42	3	●	
0.52	3	38	3	●		1.12	7	42	3	●		1.72	11	42	3	●	
0.53	3	38	3	●		1.13	7	42	3	●		1.73	11	42	3	●	
0.54	3.5	38	3	●		1.14	7	42	3	●		1.74	11	42	3	●	
0.55	3.5	38	3	●		1.15	7	42	3	●		1.75	11	42	3	●	
0.56	3.5	38	3	●		1.16	7	42	3	●		1.76	11	42	3	●	
0.57	3.5	38	3	●		1.17	7	42	3	●		1.77	11	42	3	●	
0.58	3.5	38	3	●		1.18	7	42	3	●		1.78	11	42	3	●	
0.59	3.5	38	3	●		1.19	8	42	3	●		1.79	11	42	3	●	
0.6	3.5	38	3	●		1.2	8	42	3	●		1.8	11	42	3	●	
0.61	4	38	3	●		1.21	8	42	3	●		1.81	11	42	3	●	
0.62	4	38	3	●		1.22	8	42	3	●		1.82	11	42	3	●	
0.63	4	38	3	●		1.23	8	42	3	●		1.83	11	42	3	●	
0.64	4	38	3	●		1.24	8	42	3	●		1.84	11	42	3	●	
0.65	4	38	3	●		1.25	8	42	3	●		1.85	11	42	3	●	
0.66	4	38	3	●		1.26	8	42	3	●		1.86	11	42	3	●	
0.67	4	38	3	●		1.27	8	42	3	●		1.87	11	42	3	●	
0.68	4.5	38	3	●		1.28	8	42	3	●		1.88	11	42	3	●	
0.69	4.5	38	3	●		1.29	8	42	3	●		1.89	00	42	3	●	

Borehole parameters

Work Material		GR.1 Carbon Steel		GR.2 Low-alloyed Steel (~24HRC)		GR.3 Hi-alloyed Steel (~30HRC)		GR.8 Stainless Steel		GR.9 Cast Iron		GR.10 Aluminium		GR.11 Copper	
Vc m/min		37		37		34		31		37		37		20	
Code No.	Dc	RPM (min-1)	Feed (mm/rev)	RPM (min-1)	Feed (mm/rev)	RPM (min-1)	Feed (mm/rev)	RPM (min-1)	Feed (mm/rev)	RPM (min-1)	Feed (mm/rev)	RPM (min-1)	Feed (mm/rev)	RPM (min-1)	Feed (mm/rev)
D420HX-3-0.2	0.2	25,000	0.002	25,000	0.002	25,000	0.002	25,000	0.002	25,000	0.002	25,000	0.004	25,000	0.002
D420HX-3-0.25	0.25	22,500	0.002	22,500	0.002	22,500	0.002	22,500	0.002	22,500	0.002	22,500	0.005	22,500	0.002
D420HX-3-0.3	0.3	20,000	0.003	20,000	0.003	20,000	0.003	20,000	0.003	20,000	0.003	20,000	0.007	20,000	0.003
D420HX-3-0.35	0.35	18,750	0.004	18,750	0.004	18,500	0.004	18,250	0.004	18,750	0.004	18,750	0.009	18,250	0.004
D420HX-3-0.4	0.4	17,500	0.005	17,500	0.005	17,000	0.005	16,500	0.005	17,500	0.005	17,500	0.011	16,500	0.005
D420HX-3-0.45	0.45	16,250	0.006	16,250	0.006	15,500	0.006	14,750	0.006	16,250	0.006	16,250	0.013	14,750	0.006
D420HX-3-0.5	0.5	15,000	0.007	15,000	0.007	14,000	0.007	13,000	0.007	15,000	0.007	15,000	0.015	13,000	0.007
D420HX-3-0.55	0.55	14,750	0.008	14,750	0.008	13,750	0.008	12,820	0.008	14,750	0.008	14,750	0.016	12,450	0.007
D420HX-3-0.6	0.6	14,500	0.008	14,500	0.008	13,500	0.008	12,660	0.008	14,500	0.008	14,500	0.017	11,900	0.007
D420HX-3-0.65	0.65	14,250	0.009	14,250	0.009	13,250	0.009	12,500	0.009	14,250	0.009	14,250	0.018	11,350	0.008
D420HX-3-0.7	0.7	14,000	0.009	14,000	0.009	13,000	0.009	12,320	0.009	14,000	0.009	14,000	0.018	10,800	0.008
D420HX-3-0.75	0.75	13,750	0.010	13,750	0.010	12,750	0.010	12,160	0.010	13,750	0.010	13,750	0.019	10,250	0.008
D420HX-3-0.8	0.8	13,500	0.010	13,500	0.010	12,500	0.010	12,000	0.010	13,500	0.010	13,500	0.020	9,700	0.009
D420HX-3-0.85	0.85	13,000	0.013	13,000	0.013	12,000	0.013	11,320	0.013	13,000	0.013	13,000	0.024	8,600	0.009
D420HX-3-0.9	0.9	12,500	0.016	12,500	0.016	11,500	0.016	10,660	0.016	12,500	0.016	12,500	0.037	7,500	0.010
D420HX-3-1	1	12,000	0.020	12,000	0.020	11,000	0.020	10,000	0.020	12,000	0.020	12,000	0.030	6,400	0.010
D420HX-3-1.05	1.05	11,200	0.020	11,200	0.020	10,800	0.020	9,400	0.020	11,200	0.020	11,200	0.030	6,350	0.010
D420HX-3-1.1	1.1	10,700	0.020	10,700	0.020	9,850	0.020	9,000	0.020	10,700	0.020	10,700	0.030	6,050	0.010
D420HX-3-1.15	1.15	10,250	0.025	10,250	0.025	9,400	0.025	8,550	0.025	10,250	0.025	10,250	0.030	5,500	0.010
D420HX-3-1.2	1.2	9,800	0.025	9,800	0.025	9,000	0.025	8,200	0.025	9,800	0.025	9,800	0.030	5,300	0.010
D420HX-3-1.25	1.25	9,400	0.025	9,400	0.025	8,650	0.025	7,900	0.025	9,400	0.025	9,400	0.040	5,100	0.015
D420HX-3-1.3	1.3	9,000	0.025	9,000	0.025	8,300	0.025	7,600	0.025	9,000	0.025	9,000	0.040	4,900	0.015
D420HX-3-1.35	1.35	8,700	0.030	8,700	0.030	8,000	0.030	7,300	0.030	8,700	0.030	8,700	0.040	4,700	0.015
D420HX-3-1.4	1.4	8,400	0.030	8,400	0.030	7,700	0.030	7,050	0.030	8,400	0.030	8,400	0.050	4,550	0.015
D420HX-3-1.45	1.45	8,100	0.030	8,100	0.030	7,450	0.030	6,800	0.030	8,100	0.030	8,100	0.050	4,400	0.015
D420HX-3-1.5	1.5	7,800	0.030	7,800	0.030	7,200	0.030	6,550	0.030	7,800	0.030	7,800	0.050	4,250	0.020
D420HX-3-1.55	1.55	7,600	0.035	7,600	0.035	7,000	0.035	6,350	0.035	7,600	0.035	7,600	0.050	4,100	0.020
D420HX-3-1.6	1.6	7,350	0.035	7,350	0.035	6,750	0.035	6,150	0.035	7,350	0.035	7,350	0.060	3,950	0.020
D420HX-3-1.65	1.65	7,150	0.035	7,150	0.035	6,550	0.035	5,950	0.035	7,150	0.035	7,150	0.060	3,850	0.020
D420HX-3-1.7	1.7	6,900	0.035	6,900	0.035	6,350	0.035	5,800	0.035	6,900	0.035	6,900	0.060	3,750	0.020
D420HX-3-1.75	1.75	6,700	0.035	6,700	0.035	6,200	0.035	5,650	0.035	6,700	0.035	6,700	0.060	3,650	0.025
D420HX-3-1.8	1.8	6,550	0.040	6,550	0.040	6,000	0.040	5,450	0.040	6,550	0.040	6,550	0.060	3,500	0.025
D420HX-3-1.85	1.85	6,350	0.040	6,350	0.040	5,850	0.040	5,300	0.040	6,350	0.040	6,350	0.060	3,450	0.025

1. Please work with good rigidity / high precision facilities and collet chuck.
2. Please choose proper cutting fluid.
3. The cutting data is reference value only. Please adjust it according to your real working conditions.
4. If RPM is lower the reference value, the Feed rate (fz) and RPM should be reduced by the same proportion.
5. If vibration occurs during cutting, please reduce cutting parameter.

D420HX-3

Micro Precision Drills

MG
Carbide

AlTiCrN
HX



Work Material

P	H	M	K	N	S
●		●	●	●	

P Steel

M Stainless Steel

K Cast Iron

N Aluminium

N Copper

N Plastics

Feature of product:

Micro Precision Drills

140° X-shape drill tip design which included sharp and strength.

Dc. range from 0.1 to 2.0mm with every 0.01mm as size range.

Good wear resistance and lubrication with Nano multilayer coating.

Suitable for drilling application with Steels which is below HRC30, Stainless Steels, Cast Iron, Aluminium, Copper...etc.

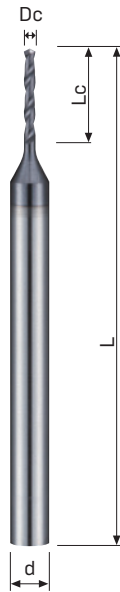

Dc 0 -0.005	Lc mm	L mm	d h6	AlTiCrN D420HX-3
1.9	11	42	3	●
1.91	12	50	3	●
1.92	12	50	3	●
1.93	12	50	3	●
1.94	12	50	3	●
1.95	12	50	3	●
1.96	12	50	3	●
1.97	12	50	3	●
1.98	12	50	3	●
1.99	12	50	3	●
2	12	50	3	●
2.01	12	50	3	○
2.02	12	50	3	○
2.03	12	50	3	○
2.04	12	50	3	○
2.05	12	50	3	●
2.06	12	50	3	○
2.07	12	50	3	○
2.08	12	50	3	○
2.09	12	50	3	○
2.1	12	50	3	●
2.11	12	50	3	○
2.12	12	50	3	○
2.13	13	50	3	○
2.14	13	50	3	○
2.15	13	50	3	●
2.16	13	50	3	○
2.17	13	50	3	○
2.18	13	50	3	○
2.19	13	50	3	○
2.2	13	50	3	●
2.21	13	50	3	○
2.22	13	50	3	○
2.23	13	50	3	○
2.24	13	50	3	○
2.25	13	50	3	●
2.26	13	50	3	○
2.27	13	50	3	○
2.28	13	50	3	○
2.29	13	50	3	○
2.3	13	50	3	●
2.31	13	50	3	○
2.32	13	50	3	○
2.33	13	50	3	○
2.34	13	50	3	○
2.35	13	50	3	●
2.36	13	50	3	○
2.37	14	50	3	○
2.38	14	50	3	○
2.39	14	50	3	○
2.4	14	50	3	●
2.41	14	50	3	○
2.42	14	50	3	○
2.43	14	50	3	○
2.44	14	50	3	○
2.45	14	50	3	●

Code No. D420HX-3-DC

Dc 0 -0.005	Lc mm	L mm	d h6	AlTiCrN D420HX-3
2.46	14	50	3	○
2.47	14	50	3	○
2.48	14	50	3	○
2.49	14	50	3	○
2.5	14	50	3	●
2.51	14	50	3	○
2.52	14	50	3	○
2.53	14	50	3	○
2.54	14	50	3	○
2.55	14	50	3	●
2.56	14	50	3	○
2.57	14	50	3	○
2.58	14	50	3	○
2.59	14	50	3	○
2.6	14	50	3	●
2.61	14	50	3	○
2.62	14	50	3	○
2.63	14	50	3	○
2.64	14	50	3	○
2.65	14	50	3	●
2.66	16	50	3	○
2.67	16	50	3	○
2.68	16	50	3	○
2.69	16	50	3	○
2.7	16	50	3	●
2.71	16	50	3	○
2.72	16	50	3	○
2.73	16	50	3	○
2.74	16	50	3	○
2.75	16	50	3	●
2.76	16	50	3	○
2.77	16	50	3	○
2.78	16	50	3	○
2.79	16	50	3	○
2.8	16	50	3	●
2.81	16	50	3	○
2.82	16	50	3	○
2.83	16	50	3	○
2.84	16	50	3	○
2.85	16	50	3	●
2.86	16	50	3	○
2.87	16	50	3	○
2.88	16	50	3	○
2.89	16	50	3	○
2.9	16	50	3	●
2.91	16	50	3	○
2.92	16	50	3	○
2.93	16	50	3	○
2.94	16	50	3	○
2.95	16	50	3	●
2.96	16	50	3	○
2.97	16	50	3	○
2.98	16	50	3	○
2.99	16	50	3	○
3	16	50	3	●

※ Mark: ○, On request, no stock

Borehole parameters

Work Material		GR.1 Carbon Steel		GR.2 Low-alloyed Steel (~24HRC)		GR.3 Hi-alloyed Steel (~30HRC)		GR.8 Stainless Steel		GR.9 Cast Iron		GR.10 Aluminium		GR.11 Copper	
Vc m/min		37		37		34		31		37		37		20	
Code No.	Dc	RPM (min-1)	Feed (mm/rev)	RPM (min-1)	Feed (mm/rev)	RPM (min-1)	Feed (mm/rev)	RPM (min-1)	Feed (mm/rev)	RPM (min-1)	Feed (mm/rev)	RPM (min-1)	Feed (mm/rev)	RPM (min-1)	Feed (mm/rev)
D420HX-3-1.9	1.9	6,200	0.040	6,200	0.040	5,700	0.040	5,200	0.040	6,200	0.040	6,200	0.060	3350	0.020
D420HX-3-1.95	1.95	6,000	0.040	6,000	0.040	5,550	0.040	5,050	0.040	6,000	0.040	6,000	0.060	3250	0.020
D420HX-3-2	2	5,900	0.050	5,900	0.050	5,400	0.050	5,000	0.050	5,900	0.050	5,900	0.060	3150	0.020
D420HX-3-2.05	2.05	5,750	0.050	5,750	0.050	5,300	0.050	4,800	0.050	5,750	0.050	5,750	0.060	3100	0.020
D420HX-3-2.1	2.1	5,600	0.050	5,600	0.050	5,150	0.050	4,700	0.050	5,600	0.050	5,600	0.080	3000	0.020
D420HX-3-2.15	2.15	5,450	0.050	5,450	0.050	5,000	0.050	4,600	0.050	5,450	0.050	5,450	0.080	2950	0.030
D420HX-3-2.2	2.2	5,350	0.050	5,350	0.050	4,900	0.050	4,500	0.050	5,350	0.050	5,350	0.080	2900	0.030
D420HX-3-2.25	2.25	5,200	0.060	5,200	0.060	4,800	0.060	4,400	0.060	5,200	0.060	5,200	0.080	2800	0.030
D420HX-3-2.3	2.3	5,100	0.060	5,100	0.060	4,700	0.060	4,300	0.060	5,100	0.060	5,100	0.080	2750	0.030
D420HX-3-2.35	2.35	5,000	0.060	5,000	0.060	4,600	0.060	4,200	0.060	5,000	0.060	5,000	0.080	2700	0.030
D420HX-3-2.4	2.4	4,900	0.060	4,900	0.060	4,500	0.060	4,100	0.060	4,900	0.060	4,900	0.080	2650	0.030
D420HX-3-2.45	2.45	4,800	0.060	4,800	0.060	4,400	0.060	4,000	0.060	4,800	0.060	4,800	0.080	2600	0.030
D420HX-3-2.5	2.5	4,700	0.080	4,700	0.080	4,300	0.080	4,332	0.080	4,700	0.080	4,700	0.100	2550	0.040
D420HX-3-2.55	2.55	4,600	0.080	4,600	0.080	4,250	0.080	3850	0.080	4,600	0.080	4,600	0.100	2500	0.040
D420HX-3-2.6	2.6	4,500	0.080	4,500	0.080	4,150	0.080	3,800	0.080	4,500	0.080	4,500	0.100	2450	0.040
D420HX-3-2.65	2.65	4,450	0.080	4,450	0.080	4,050	0.080	3,700	0.080	4,450	0.080	4,450	0.100	2400	0.040
D420HX-3-2.7	2.7	4,350	0.080	4,350	0.080	4,000	0.080	3,650	0.080	4,350	0.080	4,350	0.100	2350	0.040
D420HX-3-2.75	2.75	4,300	0.090	4,300	0.090	4,000	0.090	3,600	0.090	4,300	0.090	4,300	0.100	2300	0.050
D420HX-3-2.8	2.8	4,200	0.090	4,200	0.090	3,800	0.090	3,500	0.090	4,200	0.090	4,200	0.120	2250	0.050
D420HX-3-2.85	2.85	4,100	0.090	4,100	0.090	3,800	0.090	3,400	0.090	4,100	0.090	4,100	0.120	2200	0.050
D420HX-3-2.9	2.9	4,050	0.090	4,050	0.090	3,700	0.090	3,400	0.090	4,050	0.090	4,050	0.120	2200	0.050
D420HX-3-2.95	2.95	4,000	0.090	4,000	0.090	3,650	0.090	3,350	0.090	4,000	0.090	4,000	0.120	2150	0.050
D420HX-3-3	3	4,000	0.090	4,000	0.090	3,600	0.090	3,300	0.090	4,000	0.090	4,000	0.120	2100	0.050

1. Please work with good rigidity / high precision facilities and collet chuck.
2. Please choose proper cutting fluid.
3. The cutting data is reference value only. Please adjust it according to your real working conditions.
4. If RPM is lower the reference value, the Feed rate (fz) and RPM should be reduced by the same proportion.
5. If vibration occurs during cutting, please reduce cutting parameter.

D420HX-5

Micro Precision Drills

MG
Carbide

AlTiCrN
HX

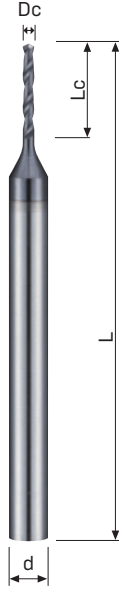

Code No. D420HX-5-DC

Work Material

P	H	M	K	N	S
●		●	●	●	

P Steel

M Stainless Steel

K Cast Iron

N Aluminium

N Copper

N Plastics

Feature of product:
 Micro Precision Drills
 140° X-shape drill tip design which included sharp and strength.
 Dc. range from 0.1 to 2.0mm with every 0.01mm as size range.
 Good wear resistance and lubrication with Nano multilayer coating.
 Suitable for drilling application with Steels which is below HRC30, Stainless Steels, Cast Iron, Aluminium, Copper...etc.

Dc					Dc					Dc				
Dc	Lc	L	d	AlTiCrN	Dc	Lc	L	d	AlTiCrN	Dc	Lc	L	d	AlTiCrN
₀ ^{-0.005}	mm	mm	h6	D420HX-5	₀ ^{-0.005}	mm	mm	h6	D420HX-5	₀ ^{-0.005}	mm	mm	h6	D420HX-5
0.1	0.9	38	3	●	0.7	7	42	3	●	1.3	12	50	3	●
0.11	0.9	38	3	○	0.71	7	42	3	○	1.31	12	50	3	○
0.12	1.1	38	3	○	0.72	7	42	3	○	1.32	12	50	3	○
0.13	1.1	38	3	○	0.73	7	42	3	○	1.33	14	50	3	○
0.14	1.1	38	3	○	0.74	7	42	3	○	1.34	14	50	3	○
0.15	1.4	38	3	●	0.75	7	42	3	●	1.35	14	50	3	●
0.16	1.4	38	3	○	0.76	7.5	42	3	○	1.36	14	50	3	○
0.17	1.4	38	3	○	0.77	7.5	42	3	○	1.37	14	50	3	○
0.18	1.7	38	3	○	0.78	7.5	42	3	○	1.38	14	50	3	○
0.19	1.7	38	3	○	0.79	7.5	42	3	○	1.39	14	50	3	○
0.2	2	38	3	●	0.8	7.5	42	3	●	1.4	14	50	3	●
0.21	2	38	3	○	0.81	7.5	42	3	○	1.41	14	50	3	○
0.22	2	38	3	○	0.82	7.5	42	3	○	1.42	14	50	3	○
0.23	2	38	3	○	0.83	7.5	42	3	○	1.43	14	50	3	○
0.24	2	38	3	○	0.84	7.5	42	3	○	1.44	14	50	3	○
0.25	2	38	3	●	0.85	7.5	42	3	●	1.45	14	50	3	●
0.26	2	38	3	○	0.86	8.5	42	3	○	1.46	14	50	3	○
0.27	2	38	3	○	0.87	8.5	42	3	○	1.47	14	50	3	○
0.28	2	38	3	○	0.88	8.5	42	3	○	1.48	14	50	3	○
0.29	2	38	3	○	0.89	8.5	42	3	○	1.49	14	50	3	○
0.3	2	38	3	●	0.9	8.5	42	3	●	1.5	14	50	3	●
0.31	3	38	3	○	0.91	8.5	42	3	○	1.51	15	50	3	○
0.32	3	38	3	○	0.92	8.5	42	3	○	1.52	15	50	3	○
0.33	3	38	3	○	0.93	8.5	42	3	○	1.53	15	50	3	○
0.34	3	38	3	○	0.94	8.5	42	3	○	1.54	15	50	3	○
0.35	3	38	3	●	0.95	8.5	42	3	●	1.55	15	50	3	●
0.36	3	38	3	○	0.96	9	42	3	○	1.56	15	50	3	○
0.37	3	38	3	○	0.97	9	42	3	○	1.57	15	50	3	○
0.38	3	38	3	○	0.98	9	42	3	○	1.58	15	50	3	○
0.39	4	38	3	○	0.99	9	42	3	○	1.59	15	50	3	○
0.4	4	38	3	●	1	9	42	3	●	1.6	15	50	3	●
0.41	4	38	3	○	1.01	9	42	3	○	1.61	15	54	3	○
0.42	4	38	3	○	1.02	9	42	3	○	1.62	15	54	3	○
0.43	4	38	3	○	1.03	9	42	3	○	1.63	15	54	3	○
0.44	4	38	3	○	1.04	9	42	3	○	1.64	15	54	3	○
0.45	4	38	3	●	1.05	9	42	3	●	1.65	15	54	3	●
0.46	4	38	3	○	1.06	9	42	3	○	1.66	15	54	3	○
0.47	4	38	3	○	1.07	11	50	3	○	1.67	15	54	3	○
0.48	4	38	3	○	1.08	11	50	3	○	1.68	15	54	3	○
0.49	4.5	38	3	○	1.09	11	50	3	○	1.69	15	54	3	○
0.5	4.5	42	3	●	1.1	11	50	3	●	1.7	15	54	3	●
0.51	4.5	42	3	○	1.11	11	50	3	○	1.71	17	54	3	○
0.52	4.5	42	3	○	1.12	11	50	3	○	1.72	17	54	3	○
0.53	4.5	42	3	○	1.13	11	50	3	○	1.73	17	54	3	○
0.54	5.5	42	3	○	1.14	11	50	3	○	1.74	17	54	3	○
0.55	5.5	42	3	●	1.15	11	50	3	●	1.75	17	54	3	●
0.56	5.5	42	3	○	1.16	11	50	3	○	1.76	17	54	3	○
0.57	5.5	42	3	○	1.17	11	50	3	○	1.77	17	54	3	○
0.58	5.5	42	3	○	1.18	11	50	3	○	1.78	17	54	3	○
0.59	5.5	42	3	○	1.19	12	50	3	○	1.79	17	54	3	○
0.6	5.5	42	3	●	1.2	12	50	3	●	1.8	17	54	3	●
0.61	6	42	3	○	1.21	12	50	3	○	1.81	17	54	3	○
0.62	6	42	3	○	1.22	12	50	3	○	1.82	17	54	3	○
0.63	6	42	3	○	1.23	12	50	3	○	1.83	17	54	3	○
0.64	6	42	3	○	1.24	12	50	3	○	1.84	17	54	3	○
0.65	6	42	3	●	1.25	12	50	3	●	1.85	17	54	3	●
0.66	6	42	3	○	1.26	12	50	3	○	1.86	17	54	3	○
0.67	6	42	3	○	1.27	12	50	3	○	1.87	17	54	3	○
0.68	7	42	3	○	1.28	12	50	3	○	1.88	17	54	3	○
0.69	7	42	3	○	1.29	12	50	3	○	1.89	17	54	3	○

※ Mark: ○, On request, no stock

Borehole parameters

Work Material		GR.1 Carbon Steel		GR.2 Low-alloyed Steel (~24HRC)		GR.3 Hi-alloyed Steel (~30HRC)		GR.8 Stainless Steel		GR.9 Cast Iron		GR.10 Aluminium		GR.11 Copper	
Vc m/min		37		37		34		31		37		37		20	
Code No.	Dc	RPM (min-1)	Feed (mm/rev)	RPM (min-1)	Feed (mm/rev)	RPM (min-1)	Feed (mm/rev)	RPM (min-1)	Feed (mm/rev)	RPM (min-1)	Feed (mm/rev)	RPM (min-1)	Feed (mm/rev)	RPM (min-1)	Feed (mm/rev)
D420HX-5-0.2	0.2	25,000	0.002	25,000	0.002	25,000	0.002	25,000	0.002	25,000	0.002	25,000	0.004	25,000	0.002
D420HX-5-0.25	0.25	22,500	0.002	22,500	0.002	22,500	0.002	22,500	0.002	22,500	0.002	22,500	0.005	22,500	0.002
D420HX-5-0.3	0.3	20,000	0.003	20,000	0.003	20,000	0.003	20,000	0.003	20,000	0.003	20,000	0.007	20,000	0.003
D420HX-5-0.35	0.35	18,750	0.004	18,750	0.004	18,500	0.004	18,250	0.004	18,750	0.004	18,750	0.009	18,250	0.004
D420HX-5-0.4	0.4	17,500	0.005	17,500	0.005	17,000	0.005	16,500	0.005	17,500	0.005	17,500	0.011	16,500	0.005
D420HX-5-0.45	0.45	16,250	0.006	16,250	0.006	15,500	0.006	14,750	0.006	16,250	0.006	16,250	0.013	14,750	0.006
D420HX-5-0.5	0.5	15,000	0.007	15,000	0.007	14,000	0.007	13,000	0.007	15,000	0.007	15,000	0.015	13,000	0.007
D420HX-5-0.55	0.55	14,750	0.008	14,750	0.008	13,750	0.008	12,820	0.008	14,750	0.008	14,750	0.016	12,450	0.007
D420HX-5-0.6	0.6	14,500	0.008	14,500	0.008	13,500	0.008	12,660	0.008	14,500	0.008	14,500	0.017	11,900	0.007
D420HX-5-0.65	0.65	14,250	0.009	14,250	0.009	13,250	0.009	12,500	0.009	14,250	0.009	14,250	0.018	11,350	0.008
D420HX-5-0.7	0.7	14,000	0.009	14,000	0.009	13,000	0.009	12,320	0.009	14,000	0.009	14,000	0.018	10,800	0.008
D420HX-5-0.75	0.75	13,750	0.010	13,750	0.010	12,750	0.010	12,160	0.010	13,750	0.010	13,750	0.019	10,250	0.008
D420HX-5-0.8	0.8	13,500	0.010	13,500	0.010	12,500	0.010	12,000	0.010	13,500	0.010	13,500	0.020	9,700	0.009
D420HX-5-0.85	0.85	13,000	0.013	13,000	0.013	12,000	0.013	11,320	0.013	13,000	0.013	13,000	0.024	8,600	0.009
D420HX-5-0.9	0.9	12,500	0.016	12,500	0.016	11,500	0.016	10,660	0.016	12,500	0.016	12,500	0.037	7,500	0.010
D420HX-5-1	1	12,000	0.020	12,000	0.020	11,000	0.020	10,000	0.020	12,000	0.020	12,000	0.030	6,400	0.010
D420HX-5-1.05	1.05	11,200	0.020	11,200	0.020	10,800	0.020	9,400	0.020	11,200	0.020	11,200	0.030	6,350	0.010
D420HX-5-1.1	1.1	10,700	0.020	10,700	0.020	9,850	0.020	9,000	0.020	10,700	0.020	10,700	0.030	6,050	0.010
D420HX-5-1.15	1.15	10,250	0.025	10,250	0.025	9,400	0.025	8,550	0.025	10,250	0.025	10,250	0.030	5,500	0.010
D420HX-5-1.2	1.2	9,800	0.025	9,800	0.025	9,000	0.025	8,200	0.025	9,800	0.025	9,800	0.030	5,300	0.010
D420HX-5-1.25	1.25	9,400	0.025	9,400	0.025	8,650	0.025	7,900	0.025	9,400	0.025	9,400	0.040	5,100	0.015
D420HX-5-1.3	1.3	9,000	0.025	9,000	0.025	8,300	0.025	7,600	0.025	9,000	0.025	9,000	0.040	4,900	0.015
D420HX-5-1.35	1.35	8,700	0.030	8,700	0.030	8,000	0.030	7,300	0.030	8,700	0.030	8,700	0.040	4,700	0.015
D420HX-5-1.4	1.4	8,400	0.030	8,400	0.030	7,700	0.030	7,050	0.030	8,400	0.030	8,400	0.050	4,550	0.015
D420HX-5-1.45	1.45	8,100	0.030	8,100	0.030	7,450	0.030	6,800	0.030	8,100	0.030	8,100	0.050	4,400	0.015
D420HX-5-1.5	1.5	7,800	0.030	7,800	0.030	7,200	0.030	6,550	0.030	7,800	0.030	7,800	0.050	4,250	0.020
D420HX-5-1.55	1.55	7,600	0.035	7,600	0.035	7,000	0.035	6,350	0.035	7,600	0.035	7,600	0.050	4,100	0.020
D420HX-5-1.6	1.6	7,350	0.035	7,350	0.035	6,750	0.035	6,150	0.035	7,350	0.035	7,350	0.060	3,950	0.020
D420HX-5-1.65	1.65	7,150	0.035	7,150	0.035	6,550	0.035	5,950	0.035	7,150	0.035	7,150	0.060	3,850	0.020
D420HX-5-1.7	1.7	6,900	0.035	6,900	0.035	6,350	0.035	5,800	0.035	6,900	0.035	6,900	0.060	3,750	0.020
D420HX-5-1.75	1.75	6,700	0.035	6,700	0.035	6,200	0.035	5,650	0.035	6,700	0.035	6,700	0.060	3,650	0.025
D420HX-5-1.8	1.8	6,550	0.040	6,550	0.040	6,000	0.040	5,450	0.040	6,550	0.040	6,550	0.060	3,500	0.025
D420HX-5-1.85	1.85	6,350	0.040	6,350	0.040	5,850	0.040	5,300	0.040	6,350	0.040	6,350	0.060	3,450	0.025

1. Please work with good rigidity / high precision facilities and collet chuck.
2. Please choose proper cutting fluid.
3. The cutting data is reference value only. Please adjust it according to your real working conditions.
4. If RPM is lower the reference value, the Feed rate (fz) and RPM should be reduced by the same proportion.
5. If vibration occurs during cutting, please reduce cutting parameter.

D420HX-5

Micro Precision Drills

MG
Carbide

AlTiCrN
HX

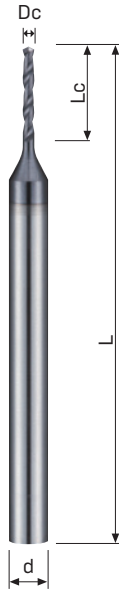

Work Material

P	H	M	K	N	S
●		●	●	●	

P Steel

M Stainless Steel

K Cast Iron

N Aluminium

N Copper

N Plastics

Feature of product:

Micro Precision Drills

140° X-shape drill tip design which included sharp and strength.

Dc. range from 0.1 to 2.0mm with every 0.01mm as size range.

Good wear resistance and lubrication with Nano multilayer coating.

Suitable for drilling application with Steels which is below HRC30, Stainless Steels, Cast Iron, Aluminium, Copper...etc.

Code No. D420HX-5-DC

Dc -0.005 0	Lc mm	L mm	d h6	AlTiCrN D420HX-5	Dc -0.005 0	Lc mm	L mm	d h6	AlTiCrN D420HX-5
1.9	17	54	3	●	2.46	22	58	3	○
1.91	18	54	3	○	2.47	22	58	3	○
1.92	18	54	3	○	2.48	22	58	3	○
1.93	18	54	3	○	2.49	22	58	3	○
1.94	18	54	3	○	2.5	22	58	3	●
1.95	18	54	3	●	2.51	22	58	3	○
1.96	18	54	3	○	2.52	22	58	3	○
1.97	18	54	3	○	2.53	22	58	3	○
1.98	18	54	3	○	2.54	22	58	3	○
1.99	18	54	3	○	2.55	22	58	3	○
2.0	18	54	3	●	2.56	22	58	3	○
2.01	18	58	3	○	2.57	22	58	3	○
2.02	18	58	3	○	2.58	22	58	3	○
2.03	18	58	3	○	2.59	22	58	3	○
2.04	18	58	3	○	2.6	22	58	3	●
2.05	18	58	3	○	2.61	22	58	3	○
2.06	18	58	3	○	2.62	22	58	3	○
2.07	18	58	3	○	2.63	22	58	3	○
2.08	18	58	3	○	2.64	22	58	3	○
2.09	18	58	3	○	2.65	22	58	3	○
2.1	18	58	3	●	2.66	25	62	3	○
2.11	18	58	3	○	2.67	25	62	3	○
2.12	18	58	3	○	2.68	25	62	3	○
2.13	20	58	3	○	2.69	25	62	3	○
2.14	20	58	3	○	2.7	25	62	3	●
2.15	20	58	3	○	2.71	25	62	3	○
2.16	20	58	3	○	2.72	25	62	3	○
2.17	20	58	3	○	2.73	25	62	3	○
2.18	20	58	3	○	2.74	25	62	3	○
2.19	20	58	3	○	2.75	25	62	3	○
2.2	20	58	3	●	2.76	25	62	3	○
2.21	20	58	3	○	2.77	25	62	3	○
2.22	20	58	3	○	2.78	25	62	3	○
2.23	20	58	3	○	2.79	25	62	3	○
2.24	20	58	3	○	2.8	25	62	3	●
2.25	20	58	3	○	2.81	25	62	3	○
2.26	20	58	3	○	2.82	25	62	3	○
2.27	20	58	3	○	2.83	25	62	3	○
2.28	20	58	3	○	2.84	25	62	3	○
2.29	20	58	3	○	2.85	25	62	3	○
2.3	20	58	3	●	2.86	25	62	3	○
2.31	20	58	3	○	2.87	25	62	3	○
2.32	20	58	3	○	2.88	25	62	3	○
2.33	20	58	3	○	2.89	25	62	3	○
2.34	20	58	3	○	2.9	25	62	3	●
2.35	20	58	3	○	2.91	25	62	3	○
2.36	20	58	3	○	2.92	25	62	3	○
2.37	22	58	3	○	2.93	25	62	3	○
2.38	22	58	3	○	2.94	25	62	3	○
2.39	22	58	3	○	2.95	25	62	3	○
2.4	22	58	3	●	2.96	25	62	3	○
2.41	22	58	3	○	2.97	25	62	3	○
2.42	22	58	3	○	2.98	25	62	3	○
2.43	22	58	3	○	2.99	25	62	3	○
2.44	22	58	3	○	3	25	62	3	●
2.45	22	58	3	○					

※ Mark: ○, On request, no stock

Borehole parameters

Work Material		GR.1 Carbon Steel		GR.2 Low-alloyed Steel (~24HRC)		GR.3 Hi-alloyed Steel (~30HRC)		GR.8 Stainless Steel		GR.9 Cast Iron		GR.10 Aluminium		GR.11 Copper	
Vc m/min		37		37		34		31		37		37		20	
Code No.	Dc	RPM (min-1)	Feed (mm/rev)	RPM (min-1)	Feed (mm/rev)	RPM (min-1)	Feed (mm/rev)	RPM (min-1)	Feed (mm/rev)	RPM (min-1)	Feed (mm/rev)	RPM (min-1)	Feed (mm/rev)	RPM (min-1)	Feed (mm/rev)
D420HX-5-1.9	1.9	6,200	0.040	6,200	0.040	5,700	0.040	5,200	0.040	6,200	0.040	6,200	0.060	3350	0.020
D420HX-5-1.95	1.95	6,000	0.040	6,000	0.040	5,550	0.040	5,050	0.040	6,000	0.040	6,000	0.060	3250	0.020
D420HX-5-2	2	5,900	0.050	5,900	0.050	5,400	0.050	5,000	0.050	5,900	0.050	5,900	0.060	3150	0.020
D420HX-5-2.05	2.05	5,750	0.050	5,750	0.050	5,300	0.050	4,800	0.050	5,750	0.050	5,750	0.060	3100	0.020
D420HX-5-2.1	2.1	5,600	0.050	5,600	0.050	5,150	0.050	4,700	0.050	5,600	0.050	5,600	0.080	3000	0.020
D420HX-5-2.15	2.15	5,450	0.050	5,450	0.050	5,000	0.050	4,600	0.050	5,450	0.050	5,450	0.080	2950	0.030
D420HX-5-2.2	2.2	5,350	0.050	5,350	0.050	4,900	0.050	4,500	0.050	5,350	0.050	5,350	0.080	2900	0.030
D420HX-5-2.25	2.25	5,200	0.060	5,200	0.060	4,800	0.060	4,400	0.060	5,200	0.060	5,200	0.080	2800	0.030
D420HX-5-2.3	2.3	5,100	0.060	5,100	0.060	4,700	0.060	4,300	0.060	5,100	0.060	5,100	0.080	2750	0.030
D420HX-5-2.35	2.35	5,000	0.060	5,000	0.060	4,600	0.060	4,200	0.060	5,000	0.060	5,000	0.080	2700	0.030
D420HX-5-2.4	2.4	4,900	0.060	4,900	0.060	4,500	0.060	4,100	0.060	4,900	0.060	4,900	0.080	2650	0.030
D420HX-5-2.45	2.45	4,800	0.060	4,800	0.060	4,400	0.060	4,000	0.060	4,800	0.060	4,800	0.080	2600	0.030
D420HX-5-2.5	2.5	4,700	0.080	4,700	0.080	4,300	0.080	4,332	0.080	4,700	0.080	4,700	0.100	2550	0.040
D420HX-5-2.55	2.55	4,600	0.080	4,600	0.080	4,250	0.080	3850	0.080	4,600	0.080	4,600	0.100	2500	0.040
D420HX-5-2.6	2.6	4,500	0.080	4,500	0.080	4,150	0.080	3,800	0.080	4,500	0.080	4,500	0.100	2450	0.040
D420HX-5-2.65	2.65	4,450	0.080	4,450	0.080	4,050	0.080	3,700	0.080	4,450	0.080	4,450	0.100	2400	0.040
D420HX-5-2.7	2.7	4,350	0.080	4,350	0.080	4,000	0.080	3,650	0.080	4,350	0.080	4,350	0.100	2350	0.040
D420HX-5-2.75	2.75	4,300	0.090	4,300	0.090	4,000	0.090	3,600	0.090	4,300	0.090	4,300	0.100	2300	0.050
D420HX-5-2.8	2.8	4,200	0.090	4,200	0.090	3,800	0.090	3,500	0.090	4,200	0.090	4,200	0.120	2250	0.050
D420HX-5-2.85	2.85	4,100	0.090	4,100	0.090	3,800	0.090	3,400	0.090	4,100	0.090	4,100	0.120	2200	0.050
D420HX-5-2.9	2.9	4,050	0.090	4,050	0.090	3,700	0.090	3,400	0.090	4,050	0.090	4,050	0.120	2200	0.050
D420HX-5-2.95	2.95	4,000	0.090	4,000	0.090	3,650	0.090	3,350	0.090	4,000	0.090	4,000	0.120	2150	0.050
D420HX-5-3	3	4,000	0.090	4,000	0.090	3,600	0.090	3,300	0.090	4,000	0.090	4,000	0.120	2100	0.050

1. Please work with good rigidity / high precision facilities and collet chuck.
2. Please choose proper cutting fluid.
3. The cutting data is reference value only. Please adjust it according to your real working conditions.
4. If RPM is lower the reference value, the Feed rate (fz) and RPM should be reduced by the same proportion.
5. If vibration occurs during cutting, please reduce cutting parameter.

D420HX-8

Micro Precision Drills

MG
Carbide

AlTiCrN
HX

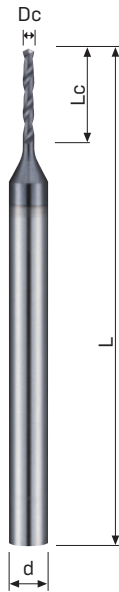

Code No. D420HX-8-DC

Work Material

P	H	M	K	N	S
●	○	●	●	●	○

P Steel

M Stainless Steel

K Cast Iron

N Aluminium

N Copper

N Plastics

Feature of product:
 Micro Precision Drills
 140° X-shape drill tip design which included sharp and strength.
 Dc. range from 0.1 to 2.0mm with every 0.01mm as size range.
 Good wear resistance and lubrication with Nano multilayer coating.
 Suitable for drilling application with Steels which is below HRC30, Stainless Steels, Cast Iron, Aluminium, Copper...etc.

Dc					Dc					Dc				
Dc	Lc	L	d	AlTiCrN	Dc	Lc	L	d	AlTiCrN	Dc	Lc	L	d	AlTiCrN
-0.005	mm	mm	h6	D420HX-8	-0.005	mm	mm	h6	D420HX-8	-0.005	mm	mm	h6	D420HX-8
0.1	1.2	38	3	●	0.7	8.4	46	3	●	1.3	15.6	50	3	●
0.11	1.2	38	3	○	0.71	9	46	3	○	1.31	16.2	54	3	○
0.12	1.4	38	3	○	0.72	9	46	3	○	1.32	16.2	54	3	○
0.13	1.4	38	3	○	0.73	9	46	3	○	1.33	16.2	54	3	○
0.14	1.4	38	3	○	0.74	9	46	3	○	1.34	16.2	54	3	○
0.15	1.8	38	3	●	0.75	9	46	3	●	1.35	16.2	54	3	●
0.16	1.8	38	3	○	0.76	9.6	46	3	○	1.36	16.8	54	3	○
0.17	1.8	38	3	○	0.77	9.6	46	3	○	1.37	16.8	54	3	○
0.18	2.1	38	3	○	0.78	9.6	46	3	○	1.38	16.8	54	3	○
0.19	2.1	38	3	○	0.79	9.6	46	3	○	1.39	16.8	54	3	○
0.2	2.4	38	3	●	0.8	9.6	46	3	●	1.4	16.8	54	3	●
0.21	2.4	38	3	○	0.81	10.2	46	3	○	1.41	17.4	54	3	○
0.22	2.6	38	3	○	0.82	10.2	46	3	○	1.42	17.4	54	3	○
0.23	2.6	38	3	○	0.83	10.2	46	3	○	1.43	17.4	54	3	○
0.24	2.6	38	3	○	0.84	10.2	46	3	○	1.44	17.4	54	3	○
0.25	3	38	3	●	0.85	10.2	46	3	●	1.45	17.4	54	3	●
0.26	3	38	3	○	0.86	10.8	46	3	○	1.46	18	54	3	○
0.27	3	38	3	○	0.87	10.8	46	3	○	1.47	18	54	3	○
0.28	3.3	38	3	○	0.88	10.8	46	3	○	1.48	18	54	3	○
0.29	3.3	38	3	○	0.89	10.8	46	3	○	1.49	18	54	3	○
0.3	5	38	3	●	0.9	10.8	46	3	●	1.5	18	54	3	●
0.31	5	38	3	○	0.91	11.4	46	3	○	1.51	18.6	54	3	○
0.32	5	38	3	○	0.92	11.4	46	3	○	1.52	18.6	54	3	○
0.33	5	38	3	○	0.93	11.4	46	3	○	1.53	18.6	54	3	○
0.34	5	38	3	○	0.94	11.4	46	3	○	1.54	18.6	54	3	○
0.35	5	38	3	●	0.95	11.4	46	3	●	1.55	18.6	54	3	●
0.36	5	38	3	○	0.96	12	46	3	○	1.56	19.2	54	3	○
0.37	5	38	3	○	0.97	12	46	3	○	1.57	19.2	54	3	○
0.38	5	38	3	○	0.98	12	46	3	○	1.58	19.2	54	3	○
0.39	5	38	3	○	0.99	12	46	3	○	1.59	19.2	54	3	○
0.4	6	38	3	●	1	12	46	3	●	1.6	19.2	54	3	●
0.41	6	38	3	○	1.01	12.6	50	3	○	1.61	19.8	58	3	○
0.42	6	38	3	○	1.02	12.6	50	3	○	1.62	19.8	58	3	○
0.43	6	38	3	○	1.03	12.6	50	3	○	1.63	19.8	58	3	○
0.44	6	38	3	○	1.04	12.6	50	3	○	1.64	19.8	58	3	○
0.45	6	38	3	●	1.05	12.6	50	3	●	1.65	19.8	58	3	●
0.46	6	38	3	○	1.06	12.6	50	3	○	1.66	20.4	58	3	○
0.47	6	38	3	○	1.07	13.2	50	3	○	1.67	20.4	58	3	○
0.48	6	38	3	○	1.08	13.2	50	3	○	1.68	20.4	58	3	○
0.49	6	38	3	○	1.09	13.2	50	3	○	1.69	20.4	58	3	○
0.5	6	42	3	●	1.1	13.2	50	3	●	1.7	20.4	58	3	●
0.51	6	42	3	○	1.11	13.8	50	3	○	1.71	21	58	3	○
0.52	6	42	3	○	1.12	13.8	50	3	○	1.72	21	58	3	○
0.53	6	42	3	○	1.13	13.8	50	3	○	1.73	21	58	3	○
0.54	6.6	42	3	○	1.14	13.8	50	3	○	1.74	21	58	3	○
0.55	6.6	42	3	●	1.15	13.8	50	3	●	1.75	21	58	3	●
0.56	7.2	42	3	○	1.16	13.8	50	3	○	1.76	21.6	58	3	○
0.57	7.2	42	3	○	1.17	13.8	50	3	○	1.77	21.6	58	3	○
0.58	7.2	42	3	○	1.18	13.8	50	3	○	1.78	21.6	58	3	○
0.59	7.2	42	3	○	1.19	14.4	50	3	○	1.79	21.6	58	3	○
0.6	7.2	42	3	●	1.2	14.4	50	3	●	1.8	21.6	58	3	●
0.61	7.8	46	3	○	1.21	15	50	3	○	1.81	22.2	58	3	○
0.62	7.8	46	3	○	1.22	15	50	3	○	1.82	22.2	58	3	○
0.63	7.8	46	3	○	1.23	15	50	3	○	1.83	22.2	58	3	○
0.64	7.8	46	3	○	1.24	15	50	3	○	1.84	22.2	58	3	○
0.65	7.8	46	3	●	1.25	15	50	3	●	1.85	22.2	58	3	●
0.66	7.8	46	3	○	1.26	15.6	50	3	○	1.86	22.8	58	3	○
0.67	7.8	46	3	○	1.27	15.6	50	3	○	1.87	22.8	58	3	○
0.68	8.4	46	3	○	1.28	15.6	50	3	○	1.88	22.8	58	3	○
0.69	8.4	46	3	○	1.29	15.6	50	3	○	1.89	22.8	58	3	○

※ Mark: ○, On request, no stock

Borehole parameters

Work Material		GR.1 Carbon Steel		GR.2 Low-alloyed Steel (~24HRC)		GR.3 Hi-alloyed Steel (~30HRC)		GR.8 Stainless Steel		GR.9 Cast Iron		GR.10 Aluminium		GR.11 Copper	
Vc m/min		37		37		34		31		37		37		20	
Code No.	Dc	RPM (min-1)	Feed (mm/rev)	RPM (min-1)	Feed (mm/rev)	RPM (min-1)	Feed (mm/rev)	RPM (min-1)	Feed (mm/rev)	RPM (min-1)	Feed (mm/rev)	RPM (min-1)	Feed (mm/rev)	RPM (min-1)	Feed (mm/rev)
D420HX-8-0.2	0.2	25,000	0.002	25,000	0.002	25,000	0.002	22,500	0.002	25,000	0.002	25,000	0.003	22,500	0.002
D420HX-8-0.25	0.25	22,500	0.002	22,500	0.002	22,500	0.002	20,250	0.002	22,500	0.002	22,500	0.004	20,250	0.002
D420HX-8-0.3	0.3	20,000	0.003	20,000	0.003	20,000	0.003	18,000	0.003	20,000	0.003	20,000	0.006	18,000	0.003
D420HX-8-0.35	0.35	18,750	0.004	18,750	0.004	18,750	0.004	16,875	0.004	18,750	0.004	18,750	0.008	16,875	0.003
D420HX-8-0.4	0.4	17,500	0.005	17,500	0.005	17,500	0.005	15,750	0.005	17,500	0.005	17,500	0.010	15,750	0.003
D420HX-8-0.45	0.45	16,250	0.005	16,250	0.005	16,250	0.005	14,625	0.005	16,250	0.005	16,250	0.010	14,625	0.004
D420HX-8-0.5	0.5	15,000	0.006	15,000	0.006	15,000	0.006	13,500	0.005	15,000	0.006	15,000	0.013	13,500	0.004
D420HX-8-0.55	0.55	14,750	0.006	14,750	0.006	14,750	0.006	13,275	0.005	14,750	0.006	14,750	0.015	13,275	0.004
D420HX-8-0.6	0.6	14,500	0.007	14,500	0.007	14,500	0.007	13,050	0.006	14,500	0.007	14,500	0.017	13,050	0.005
D420HX-8-0.65	0.65	14,250	0.007	14,250	0.007	14,250	0.007	12,825	0.006	14,250	0.007	14,250	0.018	12,825	0.005
D420HX-8-0.7	0.7	14,000	0.008	14,000	0.008	14,000	0.008	12,600	0.007	14,000	0.008	14,000	0.018	12,600	0.006
D420HX-8-0.75	0.75	13,750	0.008	13,750	0.008	13,750	0.008	12,375	0.007	13,750	0.008	13,750	0.019	12,375	0.006
D420HX-8-0.8	0.8	13,500	0.011	13,500	0.011	13,500	0.011	12,150	0.010	13,500	0.011	13,500	0.020	12,150	0.007
D420HX-8-0.85	0.85	13,000	0.012	13,000	0.012	13,000	0.012	11,700	0.011	13,000	0.012	13,000	0.024	11,700	0.007
D420HX-8-0.9	0.9	12,500	0.013	12,500	0.013	12,500	0.013	11,250	0.012	12,500	0.013	12,500	0.026	11,250	0.008
D420HX-8-1	1	12,000	0.016	12,000	0.016	12,000	0.016	10,800	0.014	12,000	0.016	12,000	0.030	10,800	0.008
D420HX-8-1.05	1.05	11,200	0.016	11,200	0.016	11,200	0.016	10,080	0.014	11,200	0.016	11,200	0.030	10,080	0.009
D420HX-8-1.1	1.1	10,700	0.016	10,700	0.016	10,700	0.016	9,630	0.014	10,700	0.016	10,700	0.030	9,630	0.009
D420HX-8-1.15	1.15	10,250	0.020	10,250	0.020	10,250	0.020	9,225	0.018	10,250	0.020	10,250	0.030	9,225	0.010
D420HX-8-1.2	1.2	9,800	0.020	9,800	0.020	9,800	0.020	8,820	0.018	9,800	0.020	9,800	0.030	8,820	0.010
D420HX-8-1.25	1.25	9,400	0.020	9,400	0.020	9,400	0.020	8,460	0.018	9,400	0.020	9,400	0.036	8,460	0.010
D420HX-8-1.3	1.3	9,000	0.020	9,000	0.020	9,000	0.020	8,100	0.018	9,000	0.020	9,000	0.040	8,100	0.012
D420HX-8-1.35	1.35	8,700	0.024	8,700	0.024	8,700	0.024	7,830	0.022	8,700	0.024	8,700	0.040	7,830	0.012
D420HX-8-1.4	1.4	8,400	0.024	8,400	0.024	8,400	0.024	7,560	0.022	8,400	0.024	8,400	0.045	7,560	0.013
D420HX-8-1.45	1.45	8,100	0.024	8,100	0.024	8,100	0.024	7,290	0.022	8,100	0.024	8,100	0.050	7,290	0.013
D420HX-8-1.5	1.5	7,800	0.024	7,800	0.024	7,800	0.024	7,020	0.022	7,800	0.024	7,800	0.050	7,020	0.014
D420HX-8-1.55	1.55	7,600	0.028	7,600	0.028	7,600	0.028	6,840	0.025	7,600	0.028	7,600	0.055	6,840	0.014
D420HX-8-1.6	1.6	7,350	0.028	7,350	0.028	7,350	0.028	6,615	0.025	7,350	0.028	7,350	0.060	6,615	0.015
D420HX-8-1.65	1.65	7,150	0.028	7,150	0.028	7,150	0.028	6,435	0.025	7,150	0.028	7,150	0.060	6,435	0.015
D420HX-8-1.7	1.7	6,900	0.028	6,900	0.028	6,900	0.028	6,210	0.025	6,900	0.028	6,900	0.060	6,210	0.016
D420HX-8-1.75	1.75	6,700	0.028	6,700	0.028	6,700	0.028	6,030	0.025	6,700	0.028	6,700	0.060	6,030	0.016
D420HX-8-1.8	1.8	6,550	0.032	6,550	0.032	6,550	0.032	5,895	0.029	6,550	0.032	6,550	0.060	5,895	0.016
D420HX-8-1.85	1.85	6,350	0.032	6,350	0.032	6,350	0.032	5,715	0.029	6,350	0.032	6,350	0.060	5,715	0.016

1. Please work with good rigidity / high precision facilities and collet chuck.
2. Please choose proper cutting fluid.
3. The cutting data is reference value only. Please adjust it according to your real working conditions.
4. If RPM is lower the reference value, the Feed rate (fz) and RPM should be reduced by the same proportion.
5. If vibration occurs during cutting, please reduce cutting parameter.

D420HX-8

Micro Precision Drills

MG
Carbide

AlTiCrN
HX

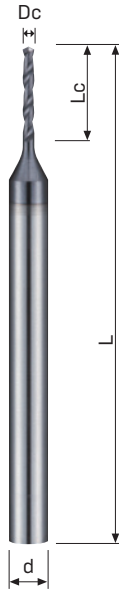

Work Material

P	H	M	K	N	S
●		●	●	●	

P Steel

M Stainless Steel

K Cast Iron

N Aluminium

N Copper

N Plastics

Feature of product:

Micro Precision Drills

140° X-shape drill tip design which included sharp and strength.

Dc. range from 0.1 to 2.0mm with every 0.01mm as size range.

Good wear resistance and lubrication with Nano multilayer coating.

Suitable for drilling application with Steels which is below HRC30, Stainless Steels, Cast Iron, Aluminium, Copper...etc.

Code No. D420HX-8-DC

Dc -0.005	Lc mm	L mm	d h6	AlTiCrN D420HX-8	Dc -0.005	Lc mm	L mm	d h6	AlTiCrN D420HX-8
1.9	22.8	58	3	●	2.46	30	66	3	○
1.91	23.4	58	3	○	2.47	30	66	3	○
1.92	23.4	58	3	○	2.48	30	66	3	○
1.93	23.4	58	3	○	2.49	30	66	3	○
1.94	23.4	58	3	○	2.5	30	66	3	●
1.95	23.4	58	3	●	2.51	30.6	66	3	○
1.96	24	58	3	○	2.52	30.6	66	3	○
1.97	24	58	3	○	2.53	30.6	66	3	○
1.98	24	58	3	○	2.54	30.6	66	3	○
1.99	24	58	3	○	2.55	30.6	66	3	○
2.0	24	58	3	●	2.56	31.2	66	3	○
2.01	24.6	62	3	○	2.57	31.2	66	3	○
2.02	24.6	62	3	○	2.58	31.2	66	3	○
2.03	24.6	62	3	○	2.59	31.2	66	3	○
2.04	24.6	62	3	○	2.6	31.2	66	3	●
2.05	24.6	62	3	○	2.61	31.8	66	3	○
2.06	25.2	62	3	○	2.62	31.8	66	3	○
2.07	25.2	62	3	○	2.63	31.8	66	3	○
2.08	25.2	62	3	○	2.64	31.8	66	3	○
2.09	25.2	62	3	○	2.65	31.8	66	3	○
2.1	25.2	62	3	●	2.66	32.4	66	3	○
2.11	25.8	62	3	○	2.67	32.4	66	3	○
2.12	25.8	62	3	○	2.68	32.4	66	3	○
2.13	25.8	62	3	○	2.69	32.4	66	3	○
2.14	25.8	62	3	○	2.7	32.4	66	3	●
2.15	25.8	62	3	○	2.71	33	66	3	○
2.16	26.4	62	3	○	2.72	33	66	3	○
2.17	26.4	62	3	○	2.73	33	66	3	○
2.18	26.4	62	3	○	2.74	33	66	3	○
2.19	26.4	62	3	○	2.75	33	66	3	○
2.2	26.4	62	3	●	2.76	33.6	66	3	○
2.21	27	62	3	○	2.77	33.6	66	3	○
2.22	27	62	3	○	2.78	33.6	66	3	○
2.23	27	62	3	○	2.79	33.6	66	3	○
2.24	27	62	3	○	2.8	33.6	66	3	●
2.25	27	62	3	○	2.81	34.2	66	3	○
2.26	27.6	62	3	○	2.82	34.2	66	3	○
2.27	27.6	62	3	○	2.83	34.2	66	3	○
2.28	27.6	62	3	○	2.84	34.2	66	3	○
2.29	27.6	62	3	○	2.85	34.2	66	3	○
2.3	27.6	62	3	●	2.86	34.8	66	3	○
2.31	28.2	62	3	○	2.87	34.8	66	3	○
2.32	28.2	62	3	○	2.88	34.8	66	3	○
2.33	28.2	62	3	○	2.89	34.8	66	3	○
2.34	28.2	62	3	○	2.9	34.8	66	3	●
2.35	28.2	62	3	○	2.91	35.4	66	3	○
2.36	28.2	62	3	○	2.92	35.4	66	3	○
2.37	28.8	62	3	○	2.93	35.4	66	3	○
2.38	28.8	62	3	○	2.94	35.4	66	3	○
2.39	28.8	62	3	○	2.95	35.4	66	3	○
2.4	28.8	62	3	●	2.96	36	66	3	○
2.41	29.4	66	3	○	2.97	36	66	3	○
2.42	29.4	66	3	○	2.98	36	66	3	○
2.43	29.4	66	3	○	2.99	36	66	3	○
2.44	29.4	66	3	○	3	36	66	3	●
2.45	29.4	66	3	○					

※ Mark: ○, On request, no stock

Borehole parameters

Work Material		GR.1 Carbon Steel		GR.2 Low-alloyed Steel (~24HRC)		GR.3 Hi-alloyed Steel (~30HRC)		GR.8 Stainless Steel		GR.9 Cast Iron		GR.10 Aluminium		GR.11 Copper	
Vc m/min		37		37		34		31		37		37		20	
Code No.	Dc	RPM (min-1)	Feed (mm/rev)	RPM (min-1)	Feed (mm/rev)	RPM (min-1)	Feed (mm/rev)	RPM (min-1)	Feed (mm/rev)	RPM (min-1)	Feed (mm/rev)	RPM (min-1)	Feed (mm/rev)	RPM (min-1)	Feed (mm/rev)
D420HX-8-1.9	1.9	6,200	0.032	6,200	0.032	5,700	0.030	5,200	0.030	6,200	0.040	6,200	0.060	3,350	0.016
D420HX-8-1.95	1.95	6,000	0.032	6,000	0.032	5,550	0.030	5,050	0.030	6,000	0.040	6,000	0.060	3,250	0.016
D420HX-8-2	2	5,900	0.040	5,900	0.040	5,400	0.036	5,000	0.036	5,900	0.050	5,900	0.060	3,150	0.018
D420HX-8-2.05	2.05	5,750	0.040	5,750	0.040	5,300	0.036	4,800	0.036	5,750	0.050	5,750	0.060	3,100	0.018
D420HX-8-2.1	2.1	5,600	0.040	5,600	0.040	5,150	0.036	4,700	0.036	5,600	0.050	5,600	0.080	3,000	0.020
D420HX-8-2.15	2.15	5,450	0.040	5,450	0.040	5,000	0.036	4,600	0.036	5,450	0.050	5,450	0.080	2,950	0.020
D420HX-8-2.2	2.2	5,350	0.040	5,350	0.040	4,900	0.036	4,500	0.036	5,350	0.050	5,350	0.080	2,900	0.024
D420HX-8-2.25	2.25	5,200	0.048	5,200	0.048	4,800	0.045	4,400	0.045	5,200	0.060	5,200	0.080	2,800	0.024
D420HX-8-2.3	2.3	5,100	0.048	5,100	0.048	4,700	0.045	4,300	0.045	5,100	0.060	5,100	0.080	2,750	0.024
D420HX-8-2.35	2.35	5,000	0.048	5,000	0.048	4,600	0.045	4,200	0.045	5,000	0.060	5,000	0.080	2,700	0.024
D420HX-8-2.4	2.4	4,900	0.048	4,900	0.048	4,500	0.045	4,100	0.045	4,900	0.060	4,900	0.080	2,650	0.024
D420HX-8-2.45	2.45	4,800	0.048	4,800	0.048	4,400	0.045	4,000	0.045	4,800	0.060	4,800	0.080	2,600	0.024
D420HX-8-2.5	2.5	4,700	0.064	4,700	0.064	4,300	0.060	4,330	0.060	4,700	0.080	4,700	0.100	2,550	0.036
D420HX-8-2.55	2.55	4,600	0.064	4,600	0.064	450	0.060	3,850	0.060	4,600	0.080	4,600	0.100	2,500	0.036
D420HX-8-2.6	2.6	4,500	0.064	4,500	0.064	4,150	0.060	3,800	0.060	4,500	0.080	4,500	0.100	2,450	0.036
D420HX-8-2.65	2.65	4,450	0.064	4,450	0.064	4,050	0.060	3,700	0.060	4,450	0.080	4,450	0.100	2,400	0.036
D420HX-8-2.7	2.7	4,350	0.064	4,350	0.064	4,000	0.060	3,650	0.060	4,350	0.080	4,350	0.100	2,350	0.036
D420HX-8-2.75	2.75	4,300	0.072	4,300	0.072	4,000	0.070	3,600	0.070	4,300	0.090	4,300	0.100	2,300	0.050
D420HX-8-2.8	2.8	4,200	0.072	4,200	0.072	3,800	0.070	3,500	0.070	4,200	0.090	4,200	0.120	2,250	0.050
D420HX-8-2.85	2.85	4,100	0.072	4,100	0.072	3,800	0.070	3,400	0.070	4,100	0.090	4,100	0.120	2,200	0.050
D420HX-8-2.9	2.9	4,050	0.072	4,050	0.072	3,700	0.070	3,400	0.070	4,050	0.090	4,050	0.120	2,200	0.050
D420HX-8-2.95	2.95	4,000	0.072	4,000	0.072	3,650	0.070	3,350	0.070	4,000	0.090	4,000	0.120	2,150	0.050
D420HX-8-3	3	4,000	0.072	4,000	0.072	3,600	0.070	3,300	0.070	4,000	0.090	4,000	0.120	2,100	0.050

1. Please work with good rigidity / high precision facilities and collet chuck.
2. Please choose proper cutting fluid.
3. The cutting data is reference value only. Please adjust it according to your real working conditions.
4. If RPM is lower the reference value, the Feed rate (fz) and RPM should be reduced by the same proportion.
5. If vibration occurs during cutting, please reduce cutting parameter.

D421TX

High Performance Drills

Code No. D421TX-Dc

MG Carbide **AlTiSiN TX**

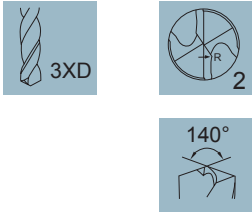

Work Material

P	H	M	K	N	S
●	●	○	●	○	○

P Steel

H <38HRC Hardened Steel

H <48HRC Hardened Steel

M Stainless Steel

K Cast Iron

S Titanium

S Nickel

S High Temp Alloys

Feature of product:

JIS 3XD Drills

140° S-shape drill tip design to reduce axial force.

Design with groove shape to provide higher chip removal rates.

Good wear resistance and lubrication with Nano multilayer coating.

Application for drilling with Steels which is below HRC48, Cast Iron, Aluminium...etc.

Suitable for drilling with 3XD depth.

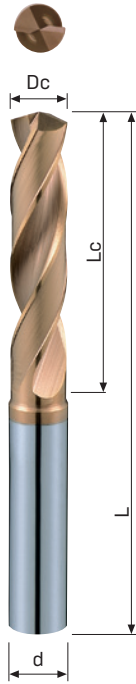

Dc h7	Lc mm	L mm	d h6	AlTiSiN D421TX	Dc h7	Lc mm	L mm	d h6	AlTiSiN D421TX
1	6	50	3	●	7	34	79	7	●
1.1	6	50	3	●	7.1	41	79	8	●
1.2	6	50	3	●	7.2	41	79	8	●
1.3	6	50	3	●	7.3	41	79	8	●
1.4	6	50	3	●	7.4	41	79	8	●
1.5	6	50	3	●	7.5	41	79	8	●
1.6	8	50	3	●	7.6	41	79	8	●
1.7	8	50	3	●	7.7	41	79	8	●
1.8	8	50	3	●	7.8	41	79	8	●
1.9	8	50	3	●	7.9	41	79	8	●
2	8	50	3	●	8	41	79	8	●
2.1	10	62	3	●	8.1	47	89	9	●
2.2	10	62	3	●	8.2	47	89	9	●
2.3	10	62	3	●	8.3	47	89	9	●
2.4	10	62	3	●	8.4	47	89	9	●
2.5	10	62	3	●	8.5	47	89	9	●
2.6	13	62	3	●	8.6	47	89	9	●
2.7	13	62	3	●	8.7	47	89	9	●
2.8	13	62	3	●	8.8	47	89	9	●
2.9	13	62	3	●	8.9	47	89	9	●
3	13	62	3	●	9	47	89	9	●
3.1	19	66	4	●	9.1	47	89	10	●
3.2	19	66	4	●	9.2	47	89	10	●
3.3	19	66	4	●	9.3	47	89	10	●
3.4	19	66	4	●	9.4	47	89	10	●
3.5	19	66	4	●	9.5	47	89	10	●
3.6	21	66	4	●	9.6	47	89	10	●
3.7	21	66	4	●	9.7	47	89	10	●
3.8	21	66	4	●	9.8	47	89	10	●
3.9	21	66	4	●	9.9	47	89	10	●
4	21	66	4	●	10	47	89	10	●
4.1	23	66	5	●	10.1	55	102	11	●
4.2	23	66	5	●	10.2	55	102	11	●
4.3	23	66	5	●	10.3	55	102	11	●
4.4	23	66	5	●	10.4	55	102	11	●
4.5	23	66	5	●	10.5	55	102	11	●
4.6	25	66	5	●	10.6	55	102	11	●
4.7	25	66	5	●	10.7	55	102	11	●
4.8	25	66	5	●	10.8	55	102	11	●
4.9	25	66	5	●	10.9	55	102	11	●
5	25	66	5	●	11	55	102	11	●
5.1	28	66	6	●	11.1	55	102	12	●
5.2	28	66	6	●	11.2	55	102	12	●
5.3	28	66	6	●	11.3	55	102	12	●
5.4	28	66	6	●	11.4	55	102	12	●
5.5	28	66	6	●	11.5	55	102	12	●
5.6	28	66	6	●	11.6	55	102	12	●
5.7	28	66	6	●	11.7	55	102	12	●
5.8	28	66	6	●	11.8	55	102	12	●
5.9	28	66	6	●	11.9	55	102	12	●
6	28	66	6	●	12	55	102	12	●
6.1	34	79	7	●	12.5	60	107	13	●
6.2	34	79	7	●	13	60	107	13	●
6.3	34	79	7	●	13.5	60	107	14	●
6.4	34	79	7	●	14	60	107	14	●
6.5	34	79	7	●	14.5	65	115	15	●
6.6	34	79	7	●	15	65	115	15	●
6.7	34	79	7	●	15.5	65	115	16	●
6.8	34	79	7	●	16	65	115	16	●
6.9	34	79	7	●					

Borehole parameters

Work Material		GR.1 Carbon Steel		GR.2 Low-alloyed Steel (~24HRC)		GR.3 Hi-alloyed Steel (~30HRC)		GR.4 Hardened Steel (30~38HRC)		GR.5 Hardened Steel (38~48HRC)		GR.9 Cast Iron	
Vc m/min		60~100		60~100		60~100		40~65		30~45		60~100	
Code No.	Dc	RPM (min-1)	Feed (mm/rev)	RPM (min-1)	Feed (mm/rev)	RPM (min-1)	Feed (mm/rev)	RPM (min-1)	Feed (mm/rev)	RPM (min-1)	Feed (mm/rev)	RPM (min-1)	Feed (mm/rev)
D421TX-1	1	19,000	0.03	19,000	0.03	19,000	0.03	12,000	0.02	10,000	0.02	19,000	0.03
D421TX-1.5	1.5	15,000	0.04	15,000	0.04	15,000	0.04	9,800	0.04	8,000	0.04	15,000	0.04
D421TX-2	2	11,000	0.06	11,000	0.06	11,000	0.06	7,600	0.06	6,000	0.06	11,000	0.06
D421TX-2.5	2.5	9,500	0.07	9,500	0.07	9,500	0.07	6,300	0.07	5,000	0.07	9,500	0.07
D421TX-3	3	8,000	0.09	8,000	0.09	8,000	0.09	5,000	0.09	4,000	0.09	8,000	0.09
D421TX-3.5	3.5	7,100	0.09	7,100	0.09	7,100	0.09	4,400	0.09	3,900	0.09	7,100	0.09
D421TX-4	4	6,300	0.10	6,300	0.10	6,300	0.10	3,800	0.10	3,800	0.10	6,300	0.10
D421TX-4.5	4.5	5,600	0.11	5,600	0.11	5,600	0.11	3,400	0.11	3,400	0.11	5,600	0.11
D421TX-5	5	5,000	0.12	5,000	0.12	5,000	0.12	3,000	0.12	3,000	0.12	5,000	0.12
D421TX-5.5	5.5	4,600	0.13	4,600	0.13	4,600	0.13	2,800	0.13	2,800	0.13	4,600	0.13
D421TX-6	6	4,200	0.14	4,200	0.14	4,200	0.14	2,600	0.14	2,600	0.14	4,200	0.14
D421TX-6.5	6.5	3,950	0.14	3,950	0.14	3,950	0.14	2,400	0.14	2,400	0.14	3,950	0.14
D421TX-7	7	3,700	0.15	3,700	0.15	3,700	0.15	2,250	0.15	2,250	0.15	3,700	0.15
D421TX-7.5	7.5	3,450	0.15	3,450	0.15	3,450	0.15	2,050	0.15	2,050	0.15	3,450	0.15
D421TX-8	8	3,200	0.16	3,200	0.16	3,200	0.16	1,900	0.16	1,900	0.16	3,200	0.16
D421TX-8.5	8.5	3,000	0.16	3,000	0.16	3,000	0.16	1,825	0.16	1,825	0.16	3,000	0.16
D421TX-9	9	2,870	0.17	2,870	0.17	2,870	0.17	1,750	0.17	1,750	0.17	2,870	0.17
D421TX-9.5	9.5	2,700	0.17	2,700	0.17	2,700	0.17	1,675	0.17	1,675	0.17	2,700	0.17
D421TX-10	10	2,550	0.18	2,550	0.18	2,550	0.18	1,600	0.18	1,600	0.18	2,550	0.18
D421TX-10.5	10.5	2,420	0.18	2,420	0.18	2,420	0.18	1,525	0.18	1,525	0.18	2,420	0.18
D421TX-11	11	2,320	0.19	2,320	0.19	2,320	0.19	1,450	0.19	1,450	0.19	2,320	0.19
D421TX-11.5	11.5	2,200	0.19	2,200	0.19	2,200	0.19	1,375	0.19	1,375	0.19	2,200	0.19
D421TX-12	12	2,100	0.20	2,100	0.20	2,100	0.20	1,300	0.20	1,300	0.20	2,100	0.20
D421TX-12.5	12.5	2,025	0.20	2,025	0.20	2,025	0.20	1,250	0.20	1,250	0.20	2,025	0.20
D421TX-13	13	1,950	0.21	1,950	0.21	1,950	0.21	1,200	0.21	1,200	0.21	1,950	0.21
D421TX-13.5	13.5	1,875	0.21	1,875	0.21	1,875	0.21	1,150	0.21	1,150	0.21	1,875	0.21
D421TX-14	14	1,800	0.22	1,800	0.22	1,800	0.22	1,100	0.22	1,100	0.22	1,800	0.22
D421TX-14.5	14.5	1,750	0.22	1,750	0.22	1,750	0.22	1,055	0.22	1,055	0.22	1,750	0.22
D421TX-15	15	1,700	0.23	1,700	0.23	1,700	0.23	1,025	0.23	1,025	0.23	1,700	0.23
D421TX-15.5	15.5	1,650	0.23	1,650	0.23	1,650	0.23	980	0.24	980	0.24	1,650	0.23
D421TX-16	16	1,600	0.25	1,600	0.25	1,600	0.25	950	0.25	950	0.25	1,600	0.25

1. Please work with good rigidity / high precision facilities and collet chuck.
2. Please choose proper cutting fluid.
3. The cutting data is reference value only. Please adjust it according to your real working conditions.
4. If RPM is lower the reference value, the Feed rate (fz) and RPM should be reduced by the same proportion.
5. If vibration occurs during cutting, please reduce cutting parameter.

D422TX

High Performance Drills

Code No. D422TX-Dc

MG
Carbide

AlTiSiN
TX



Work Material

P	H	M	K	N	S
●	●	○	●	○	○

P Steel

H <38HRC
Hardened Steel

H <48HRC
Hardened Steel

M Stainless Steel

K Cast Iron

S Titanium

S Nickel

S High Temp Alloys

Feature of product:

JIS 5XD Drills

140° S-shape drill tip design to reduce axial force.

Design with groove shape to provide higher chip removal rates.

Good wear resistance and lubrication with Nano multilayer coating.

Application for drilling with Steels which is below HRC48, Cast Iron, Aluminium...etc.

Suitable for drilling with 5XD depth.

Dc h7	Lc mm	L mm	d h6	AlTiSiN D422TX	Dc h7	Lc mm	L mm	d h6	AlTiSiN D422TX
1	12	62	3	●	7	53	91	7	●
1.1	12	62	3	●	7.1	53	91	8	●
1.2	12	62	3	●	7.2	53	91	8	●
1.3	12	62	3	●	7.3	53	91	8	●
1.4	12	62	3	●	7.4	53	91	8	●
1.5	12	62	3	●	7.5	53	91	8	●
1.6	15	62	3	●	7.6	53	91	8	●
1.7	15	62	3	●	7.7	53	91	8	●
1.8	15	62	3	●	7.8	53	91	8	●
1.9	15	62	3	●	7.9	53	91	8	●
2	15	62	3	●	8	53	91	8	●
2.1	18	66	3	●	8.1	61	103	9	●
2.2	18	66	3	●	8.2	61	103	9	●
2.3	18	66	3	●	8.3	61	103	9	●
2.4	18	66	3	●	8.4	61	103	9	●
2.5	18	66	3	●	8.5	61	103	9	●
2.6	20	66	3	●	8.6	61	103	9	●
2.7	20	66	3	●	8.7	61	103	9	●
2.8	20	66	3	●	8.8	61	103	9	●
2.9	20	66	3	●	8.9	61	103	9	●
3	20	66	3	●	9	61	103	9	●
3.1	24	74	4	●	9.1	61	103	10	●
3.2	24	74	4	●	9.2	61	103	10	●
3.3	24	74	4	●	9.3	61	103	10	●
3.4	24	74	4	●	9.4	61	103	10	●
3.5	24	74	4	●	9.5	61	103	10	●
3.6	28	74	4	●	9.6	61	103	10	●
3.7	28	74	4	●	9.7	61	103	10	●
3.8	28	74	4	●	9.8	61	103	10	●
3.9	28	74	4	●	9.9	61	103	10	●
4	28	74	4	●	10	61	103	10	●
4.1	32	74	5	●	10.1	71	118	11	●
4.2	32	74	5	●	10.2	71	118	11	●
4.3	32	74	5	●	10.3	71	118	11	●
4.4	32	74	5	●	10.4	71	118	11	●
4.5	32	74	5	●	10.5	71	118	11	●
4.6	38	74	5	●	10.6	71	118	11	●
4.7	38	74	5	●	10.7	71	118	11	●
4.8	38	74	5	●	10.8	71	118	11	●
4.9	38	74	5	●	10.9	71	118	11	●
5	38	74	5	●	11	71	118	11	●
5.1	44	82	6	●	11.1	71	118	12	●
5.2	44	82	6	●	11.2	71	118	12	●
5.3	44	82	6	●	11.3	71	118	12	●
5.4	44	82	6	●	11.4	71	118	12	●
5.5	44	82	6	●	11.5	71	118	12	●
5.6	44	82	6	●	11.6	71	118	12	●
5.7	44	82	6	●	11.7	71	118	12	●
5.8	44	82	6	●	11.8	71	118	12	●
5.9	44	82	6	●	11.9	71	118	12	●
6	44	82	6	●	12	71	118	12	●
6.1	53	91	7	●	12.5	77	124	13	●
6.2	53	91	7	●	13	77	124	13	●
6.3	53	91	7	●	13.5	77	124	14	●
6.4	53	91	7	●	14	77	124	14	●
6.5	53	91	7	●	14.5	83	133	15	●
6.6	53	91	7	●	15	83	133	15	●
6.7	53	91	7	●	15.5	83	133	16	●
6.8	53	91	7	●	16	83	133	16	●
6.9	53	91	7	●					

Borehole parameters

Work Material		GR.1 Carbon Steel		GR.2 Low-alloyed Steel (~24HRC)		GR.3 Hi-alloyed Steel (~30HRC)		GR.4 Hardened Steel (30~38HRC)		GR.5 Hardened Steel (38~48HRC)		GR.9 Cast Iron	
Vc m/min		60~100		60~100		60~100		40~65		30~45		60~100	
Code No.	Dc	RPM (min-1)	Feed (mm/rev)	RPM (min-1)	Feed (mm/rev)	RPM (min-1)	Feed (mm/rev)	RPM (min-1)	Feed (mm/rev)	RPM (min-1)	Feed (mm/rev)	RPM (min-1)	Feed (mm/rev)
D422TX-1	1	19,000	0.03	19,000	0.03	19,000	0.03	12,000	0.02	10,000	0.02	19,000	0.03
D422TX-1.5	1.5	15,000	0.04	15,000	0.04	15,000	0.04	9,800	0.04	8,000	0.04	15,000	0.04
D422TX-2	2	11,000	0.06	11,000	0.06	11,000	0.06	7,600	0.06	6,000	0.06	11,000	0.06
D422TX-2.5	2.5	9,500	0.07	9,500	0.07	9,500	0.07	6,300	0.07	5,000	0.07	9,500	0.07
D422TX-3	3	8,000	0.09	8,000	0.09	8,000	0.09	5,000	0.09	4,000	0.09	8,000	0.09
D422TX-3.5	3.5	7,100	0.09	7,100	0.09	7,100	0.09	4,400	0.09	3,900	0.09	7,100	0.09
D422TX-4	4	6,300	0.10	6,300	0.10	6,300	0.10	3,800	0.10	3,800	0.10	6,300	0.10
D422TX-4.5	4.5	5,600	0.11	5,600	0.11	5,600	0.11	3,400	0.11	3,400	0.11	5,600	0.11
D422TX-5	5	5,000	0.12	5,000	0.12	5,000	0.12	3,000	0.12	3,000	0.12	5,000	0.12
D422TX-5.5	5.5	4,600	0.13	4,600	0.13	4,600	0.13	2,800	0.13	2,800	0.13	4,600	0.13
D422TX-6	6	4,200	0.14	4,200	0.14	4,200	0.14	2,600	0.14	2,600	0.14	4,200	0.14
D422TX-6.5	6.5	3,950	0.14	3,950	0.14	3,950	0.14	2,400	0.14	2,400	0.14	3,950	0.14
D422TX-7	7	3,700	0.15	3,700	0.15	3,700	0.15	2,250	0.15	2,250	0.15	3,700	0.15
D422TX-7.5	7.5	3,450	0.15	3,450	0.15	3,450	0.15	2,050	0.15	2,050	0.15	3,450	0.15
D422TX-8	8	3,200	0.16	3,200	0.16	3,200	0.16	1,900	0.16	1,900	0.16	3,200	0.16
D422TX-8.5	8.5	3,000	0.16	3,000	0.16	3,000	0.16	1,825	0.16	1,825	0.16	3,000	0.16
D422TX-9	9	2,870	0.17	2,870	0.17	2,870	0.17	1,750	0.17	1,750	0.17	2,870	0.17
D422TX-9.5	9.5	2,700	0.17	2,700	0.17	2,700	0.17	1,675	0.17	1,675	0.17	2,700	0.17
D422TX-10	10	2,550	0.18	2,550	0.18	2,550	0.18	1,600	0.18	1,600	0.18	2,550	0.18
D422TX-10.5	10.5	2,420	0.18	2,420	0.18	2,420	0.18	1,525	0.18	1,525	0.18	2,420	0.18
D422TX-11	11	2,320	0.19	2,320	0.19	2,320	0.19	1,450	0.19	1,450	0.19	2,320	0.19
D422TX-11.5	11.5	2,200	0.19	2,200	0.19	2,200	0.19	1,375	0.19	1,375	0.19	2,200	0.19
D422TX-12	12	2,100	0.20	2,100	0.20	2,100	0.20	1,300	0.20	1,300	0.20	2,100	0.20
D422TX-12.5	12.5	2,025	0.20	2,025	0.20	2,025	0.20	1,250	0.20	1,250	0.20	2,025	0.20
D422TX-13	13	1,950	0.21	1,950	0.21	1,950	0.21	1,200	0.21	1,200	0.21	1,950	0.21
D422TX-13.5	13.5	1,875	0.21	1,875	0.21	1,875	0.21	1,150	0.21	1,150	0.21	1,875	0.21
D422TX-14	14	1,800	0.22	1,800	0.22	1,800	0.22	1,100	0.22	1,100	0.22	1,800	0.22
D422TX-14.5	14.5	1,750	0.22	1,750	0.22	1,750	0.22	1,055	0.22	1,055	0.22	1,750	0.22
D422TX-15	15	1,700	0.23	1,700	0.23	1,700	0.23	1,025	0.23	1,025	0.23	1,700	0.23
D422TX-15.5	15.5	1,650	0.23	1,650	0.23	1,650	0.23	980	0.24	980	0.24	1,650	0.23
D422TX-16	16	1,600	0.25	1,600	0.25	1,600	0.25	950	0.25	950	0.25	1,600	0.25

1. Please work with good rigidity / high precision facilities and collet chuck.
2. Please choose proper cutting fluid.
3. The cutting data is reference value only. Please adjust it according to your real working conditions.
4. If RPM is lower the reference value, the Feed rate (fz) and RPM should be reduced by the same proportion.
5. If vibration occurs during cutting, please reduce cutting parameter.

D423TX-3

Oil-Feed High Performance Drills

Code No. D423TX-3-Dc

MG
CarbideAlTiSiN
TX

Work Material

P	H	M	K	N	S
●	●	●	●	○	○

P	Steel
---	-------

H	<38HRC Hardened Steel
---	--------------------------

H	<48HRC Hardened Steel
---	--------------------------

H	<56HRC Hardened Steel
---	--------------------------

M	Stainless Steel
---	-----------------

K	Cast Iron
---	-----------

S	Titanium
---	----------

S	Nickel
---	--------

S	High Temp Alloys
---	------------------

Feature of product:

JIS 3XD Drills with Oil-Feed
140° S-shape drill tip design to
reduce axial force.

Design with groove shape to
provide higher chip removal rates.

Good wear resistance and
lubrication with Nano multilayer
coating.

Oil-feed design could reduce
temperature effectively and
increase chip removal rates
during cutting process.

Application for drilling with Steels
which is below HRC48, Cast Iron...
etc.

Suitable for drilling with 3XD
depth.

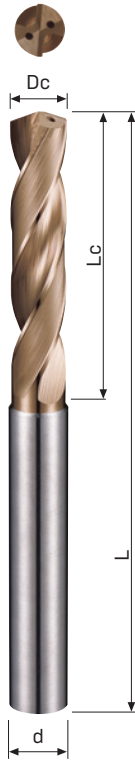

Dc h7	Lc mm	L mm	d h6	AlTiSiN D423TX-3	Dc h7	Lc mm	L mm	d h6	AlTiSiN D423TX-3
2	13	60	3	●	7.6	40	91	8	●
2.1	15	66	3	●	7.7	40	91	8	●
2.2	15	66	3	●	7.8	40	91	8	●
2.3	15	66	3	●	7.9	40	91	8	●
2.4	15	66	3	●	8	40	91	8	●
2.5	15	66	3	●	8.1	43	100	9	●
2.6	18	66	3	●	8.2	43	100	9	●
2.7	18	66	3	●	8.3	43	100	9	●
2.8	18	66	3	●	8.4	43	100	9	●
2.9	18	66	3	●	8.5	43	100	9	●
3	18	66	3	●	8.6	45	100	9	●
3.1	20	74	4	●	8.7	45	100	9	●
3.2	20	74	4	●	8.8	45	100	9	●
3.3	20	74	4	●	8.9	45	100	9	●
3.4	20	74	4	●	9	45	100	9	●
3.5	20	74	4	●	9.1	48	103	10	●
3.6	23	74	4	●	9.2	48	103	10	●
3.7	23	74	4	●	9.3	48	103	10	●
3.8	23	74	4	●	9.4	48	103	10	●
3.9	23	74	4	●	9.5	48	103	10	●
4	23	74	4	●	9.6	50	103	10	●
4.1	25	80	5	●	9.7	50	103	10	●
4.2	25	80	5	●	9.8	50	103	10	●
4.3	25	80	5	●	9.9	50	103	10	●
4.4	25	80	5	●	10	50	103	10	●
4.5	25	80	5	●	10.1	53	116	12	●
4.6	28	80	5	●	10.2	53	116	12	●
4.7	28	80	5	●	10.3	53	116	12	●
4.8	28	80	5	●	10.4	53	116	12	●
4.9	28	80	5	●	10.5	53	116	11	●
5	28	80	5	●	10.6	55	116	11	●
5.1	28	82	6	●	10.7	55	116	11	●
5.2	28	82	6	●	10.8	55	116	11	●
5.3	28	82	6	●	10.9	55	116	11	●
5.4	28	82	6	●	11	55	116	11	●
5.5	28	82	6	●	11.1	58	118	12	●
5.6	30	82	6	●	11.2	58	118	12	●
5.7	30	82	6	●	11.3	58	118	12	●
5.8	30	82	6	●	11.4	58	118	12	●
5.9	30	82	6	●	11.5	58	118	12	●
6	30	82	6	●	11.6	60	118	12	●
6.1	33	88	7	●	11.7	60	118	12	●
6.2	33	88	7	●	11.8	60	118	12	●
6.3	33	88	7	●	11.9	60	118	12	●
6.4	33	88	7	●	12	60	118	12	●
6.5	33	88	7	●	12.5	63	128	13	●
6.6	35	88	7	●	13	65	128	13	●
6.7	35	88	7	●	13.5	68	134	14	●
6.8	35	88	7	●	14	70	134	14	●
6.9	35	88	7	●	14.5	73	140	15	●
7	35	88	7	●	15	75	140	15	●
7.1	38	91	8	●	15.5	78	146	16	●
7.2	38	91	8	●	16	80	146	16	●
7.3	38	91	8	●					
7.4	38	91	8	●					
7.5	38	91	8	●					

Borehole parameters

Work Material		GR.1 Carbon Steel		GR.2 Low-alloyed Steel (~24HRC)		GR.3 Hi-alloyed Steel (~30HRC)		GR.4 Hardened Steel (30~38HRC)		GR.5 Hardened Steel (38~48HRC)		GR.8 Stainless Steel		GR.9 Cast Iron	
Vc m/min		80~150		80~150		80~150		40~70		32~50		50~80		80~150	
Code No.	Dc	RPM (min-1)	Feed (mm/rev)	RPM (min-1)	Feed (mm/rev)	RPM (min-1)	Feed (mm/rev)	RPM (min-1)	Feed (mm/rev)	RPM (min-1)	Feed (mm/rev)	RPM (min-1)	Feed (mm/rev)	RPM (min-1)	Feed (mm/rev)
D423TX-3-2	2	19,000	0.07	19,000	0.07	19,000	0.07	9,550	0.07	7,960	0.05	9,550	0.07	19,000	0.07
D423TX-3-2.5	2.5	15,300	0.08	15,300	0.08	15,300	0.08	7,600	0.08	6,370	0.06	7,650	0.08	15,300	0.08
D423TX-3-3	3	13,000	0.09	13,000	0.09	13,000	0.09	6,400	0.09	5,300	0.07	6,300	0.09	13,000	0.09
D423TX-3-3.5	3.5	11,250	0.09	11,250	0.09	11,250	0.09	5,600	0.09	4,600	0.07	5,500	0.09	11,250	0.09
D423TX-3-4	4	9,500	0.10	9,500	0.10	9,500	0.10	4,800	0.10	4,000	0.08	4,700	0.10	9,500	0.10
D423TX-3-4.5	4.5	8,550	0.11	8,550	0.11	8,550	0.11	4,300	0.11	3,600	0.09	4,250	0.11	8,550	0.11
D423TX-3-5	5	7,600	0.12	7,600	0.12	7,600	0.12	3,800	0.12	3,200	0.10	3,800	0.12	7,600	0.12
D423TX-3-5.5	5.5	7,000	0.13	7,000	0.13	7,000	0.13	3,500	0.13	2,900	0.11	3,500	0.13	7,000	0.13
D423TX-3-6	6	6,400	0.14	6,400	0.14	6,400	0.14	3,200	0.14	2,650	0.12	3,200	0.14	6,400	0.14
D423TX-3-6.5	6.5	6,000	0.14	6,000	0.14	6,000	0.14	3,000	0.14	2,450	0.12	3,000	0.14	6,000	0.14
D423TX-3-7	7	5,600	0.15	5,600	0.15	5,600	0.15	2,800	0.15	1,300	0.13	2,800	0.15	5,600	0.15
D423TX-3-7.5	7.5	5,200	0.15	5,200	0.15	5,200	0.15	2,600	0.15	1,250	0.13	2,600	0.15	5,200	0.15
D423TX-3-8	8	4,800	0.16	4,800	0.16	4,800	0.16	2,400	0.16	2,000	0.14	2,400	0.16	4,800	0.16
D423TX-3-8.5	8.5	4,550	0.16	4,550	0.16	4,550	0.16	2,275	0.16	1,900	0.14	2,275	0.16	4,550	0.16
D423TX-3-9	9	4,300	0.17	4,300	0.17	4,300	0.17	2,150	0.17	1,800	0.15	2,150	0.17	4,300	0.17
D423TX-3-9.5	9.5	4,050	0.17	4,050	0.17	4,050	0.17	2,025	0.17	1,700	0.15	2,025	0.17	4,050	0.17
D423TX-3-10	10	3,800	0.18	3,800	0.18	3,800	0.18	1,900	0.18	1,600	0.15	1,900	0.18	3,800	0.18
D423TX-3-10.5	10.5	3,650	0.18	3,650	0.18	3,650	0.18	1,825	0.18	1,525	0.15	1,825	0.18	3,650	0.18
D423TX-3-11	11	3,500	0.19	3,500	0.19	3,500	0.19	1,750	0.19	1,450	0.16	1,750	0.19	3,500	0.19
D423TX-3-11.5	11.5	3,350	0.19	3,350	0.19	3,350	0.19	1,675	0.19	1,375	0.16	1,675	0.19	3,350	0.19
D423TX-3-12	12	3,200	0.20	3,200	0.20	3,200	0.20	1,600	0.20	1,300	0.17	1,600	0.20	3,200	0.20
D423TX-3-12.5	12.5	3,075	0.20	3,075	0.20	3,075	0.20	1,535	0.20	1,275	0.17	1,535	0.20	3,075	0.20
D423TX-3-13	13	2,950	0.21	2,950	0.21	2,950	0.21	1,475	0.21	1,250	0.18	1,475	0.21	2,950	0.21
D423TX-3-13.5	13.5	2,775	0.21	2,775	0.21	2,775	0.21	1,400	0.21	1,225	0.18	1,400	0.21	2,775	0.21
D423TX-3-14	14	2,700	0.22	2,700	0.22	2,700	0.22	1,350	0.22	1,200	0.18	1,350	0.22	2,700	0.22
D423TX-3-14.5	14.5	2,625	0.23	2,625	0.23	2,625	0.23	1,310	0.23	1,150	0.18	1,310	0.23	2,625	0.23
D423TX-3-15	15	2,550	0.24	2,550	0.24	2,550	0.24	1,275	0.24	1,100	0.19	1,275	0.24	2,550	0.24
D423TX-3-15.5	15.5	2,475	0.24	2,475	0.24	2,475	0.24	1,235	0.24	1,050	0.19	1,235	0.24	2,475	0.24
D423TX-3-16	16	2,400	0.25	2,400	0.25	2,400	0.25	1,200	0.25	1,000	0.20	1,200	0.25	2,400	0.25

1. Please work with good rigidity / high precision facilities and collet chuck.
2. Please choose proper cutting fluid.
3. The cutting data is reference value only. Please adjust it according to your real working conditions.
4. If RPM is lower the reference value, the Feed rate (fz) and RPM should be reduced by the same proportion.
5. If vibration occurs during cutting, please reduce cutting parameter.

D423TX-5

Oil-Feed High Performance Drills

Code No. D423TX-5-Dc

MG
CarbideAlTiSiN
TX

Work Material

P	H	M	K	N	S
●	●	●	●	○	○

P	Steel
---	-------

H	<38HRC Hardened Steel
---	--------------------------

H	<48HRC Hardened Steel
---	--------------------------

M	Stainless Steel
---	-----------------

K	Cast Iron
---	-----------

S	Titanium
---	----------

S	Nickel
---	--------

S	High Temp Alloys
---	------------------

Feature of product:

JIS 5XD Drills with Oil-Feed

140° S-shape drill tip design to reduce axial force.

Design with groove shape to provide higher chip removal rates.

Good wear resistance and lubrication with Nano multilayer coating.

Oil-feed design could reduce temperature effectively and increase chip removal rates during cutting process.

Application for drilling with Steels which is below HRC48, Cast Iron... etc.

Suitable for drilling with 5XD depth.



Dc h7	Lc mm	L mm	d h6	AlTiSiN D423TX-5
2	19	70	3	●
2.1	24	78	3	●
2.2	24	78	3	●
2.3	24	78	3	●
2.4	24	78	3	●
2.5	24	78	3	●
2.6	28	78	3	●
2.7	28	78	3	●
2.8	28	78	3	●
2.9	28	78	3	●
3	28	78	3	●
3.1	32	86	4	●
3.2	32	86	4	●
3.3	32	86	4	●
3.4	32	86	4	●
3.5	32	86	4	●
3.6	36	86	4	●
3.7	36	86	4	●
3.8	36	86	4	●
3.9	36	86	4	●
4	36	86	4	●
4.1	40	95	5	●
4.2	40	95	5	●
4.3	40	95	5	●
4.4	40	95	5	●
4.5	40	95	5	●
4.6	44	95	5	●
4.7	44	95	5	●
4.8	44	95	5	●
4.9	44	95	5	●
5	44	95	5	●
5.1	44	97	6	●
5.2	44	97	6	●
5.3	44	97	6	●
5.4	44	97	6	●
5.5	44	97	6	●
5.6	48	97	6	●
5.7	48	97	6	●
5.8	48	97	6	●
5.9	48	97	6	●
6	48	97	6	●
6.1	52	109	7	●
6.2	52	109	7	●
6.3	52	109	7	●
6.4	52	109	7	●
6.5	52	109	7	●
6.6	56	109	7	●
6.7	56	109	7	●
6.8	56	109	7	●
6.9	56	109	7	●
7	56	109	7	●
7.1	60	116	8	●
7.2	60	116	8	●
7.3	60	116	8	●
7.4	60	116	8	●
7.5	60	116	8	●

Dc h7	Lc mm	L mm	d h6	AlTiSiN D423TX-5
7.6	64	116	8	●
7.7	64	116	8	●
7.8	64	116	8	●
7.9	64	116	8	●
8	64	116	8	●
8.1	68	127	9	●
8.2	68	127	9	●
8.3	68	127	9	●
8.4	68	127	9	●
8.5	68	127	9	●
8.6	72	127	9	●
8.7	72	127	9	●
8.8	72	127	9	●
8.9	72	127	9	●
9	72	127	9	●
9.1	76	139	10	●
9.2	76	139	10	●
9.3	76	139	10	●
9.4	76	139	10	●
9.5	76	139	10	●
9.6	80	139	10	●
9.7	80	139	10	●
9.8	80	139	10	●
9.9	80	139	10	●
10	80	139	10	●
10.1	84	149	11	●
10.2	84	149	11	●
10.3	84	149	11	●
10.4	84	149	11	●
10.5	84	149	11	●
10.6	88	149	11	●
10.7	88	149	11	●
10.8	88	149	11	●
10.9	88	149	11	●
11	88	149	11	●
11.1	92	163	12	●
11.2	92	163	12	●
11.3	92	163	12	●
11.4	92	163	12	●
11.5	92	163	12	●
11.6	96	163	12	●
11.7	96	163	12	●
11.8	96	163	12	●
11.9	96	163	12	●
12	96	163	12	●
12.5	100	167	13	●
13	104	167	13	●
13.5	108	176	14	●
14	112	176	14	●
14.5	116	185	15	●
15	120	185	15	●
15.5	124	194	16	●
16	128	194	16	●

Borehole parameters

Work Material		GR.1 Carbon Steel		GR.2 Low-alloyed Steel (~24HRC)		GR.3 Hi-alloyed Steel (~30HRC)		GR.4 Hardened Steel (30~38HRC)		GR.5 Hardened Steel (38~48HRC)		GR.8 Stainless Steel		GR.9 Cast Iron	
Vc m/min		80~150		80~150		80~150		40~70		32~50		50~80		80~150	
Code No.	Dc	RPM (min-1)	Feed (mm/rev)	RPM (min-1)	Feed (mm/rev)	RPM (min-1)	Feed (mm/rev)	RPM (min-1)	Feed (mm/rev)	RPM (min-1)	Feed (mm/rev)	RPM (min-1)	Feed (mm/rev)	RPM (min-1)	Feed (mm/rev)
D423TX-5-2	2	19,000	0.07	19,000	0.07	19,000	0.07	9,550	0.07	7,960	0.05	9,550	0.07	19,000	0.07
D423TX-5-2.5	2.5	15,300	0.08	15,300	0.08	15,300	0.08	7,600	0.08	6,370	0.06	7,650	0.08	15,300	0.08
D423TX-5-3	3	13,000	0.09	13,000	0.09	13,000	0.09	6,400	0.09	5,300	0.07	6,300	0.09	13,000	0.09
D423TX-5-3.5	3.5	11,250	0.09	11,250	0.09	11,250	0.09	5,600	0.09	4,600	0.07	5,500	0.09	11,250	0.09
D423TX-5-4	4	9,500	0.10	9,500	0.10	9,500	0.10	4,800	0.10	4,000	0.08	4,700	0.10	9,500	0.10
D423TX-5-4.5	4.5	8,550	0.11	8,550	0.11	8,550	0.11	4,300	0.11	3,600	0.09	4,250	0.11	8,550	0.11
D423TX-5-5	5	7,600	0.12	7,600	0.12	7,600	0.12	3,800	0.12	3,200	0.10	3,800	0.12	7,600	0.12
D423TX-5-5.5	5.5	7,000	0.13	7,000	0.13	7,000	0.13	3,500	0.13	2,900	0.11	3,500	0.13	7,000	0.13
D423TX-5-6	6	6,400	0.14	6,400	0.14	6,400	0.14	3,200	0.14	2,650	0.12	3,200	0.14	6,400	0.14
D423TX-5-6.5	6.5	6,000	0.14	6,000	0.14	6,000	0.14	3,000	0.14	2,450	0.12	3,000	0.14	6,000	0.14
D423TX-5-7	7	5,600	0.15	5,600	0.15	5,600	0.15	2,800	0.15	1,300	0.13	2,800	0.15	5,600	0.15
D423TX-5-7.5	7.5	5,200	0.15	5,200	0.15	5,200	0.15	2,600	0.15	1,250	0.13	2,600	0.15	5,200	0.15
D423TX-5-8	8	4,800	0.16	4,800	0.16	4,800	0.16	2,400	0.16	2,000	0.14	2,400	0.16	4,800	0.16
D423TX-5-8.5	8.5	4,550	0.16	4,550	0.16	4,550	0.16	2,275	0.16	1,900	0.14	2,275	0.16	4,550	0.16
D423TX-5-9	9	4,300	0.17	4,300	0.17	4,300	0.17	2,150	0.17	1,800	0.15	2,150	0.17	4,300	0.17
D423TX-5-9.5	9.5	4,050	0.17	4,050	0.17	4,050	0.17	2,025	0.17	1,700	0.15	2,025	0.17	4,050	0.17
D423TX-5-10	10	3,800	0.18	3,800	0.18	3,800	0.18	1,900	0.18	1,600	0.15	1,900	0.18	3,800	0.18
D423TX-5-10.5	10.5	3,650	0.18	3,650	0.18	3,650	0.18	1,825	0.18	1,525	0.15	1,825	0.18	3,650	0.18
D423TX-5-11	11	3,500	0.19	3,500	0.19	3,500	0.19	1,750	0.19	1,450	0.16	1,750	0.19	3,500	0.19
D423TX-5-11.5	11.5	3,350	0.19	3,350	0.19	3,350	0.19	1,675	0.19	1,375	0.16	1,675	0.19	3,350	0.19
D423TX-5-12	12	3,200	0.20	3,200	0.20	3,200	0.20	1,600	0.20	1,300	0.17	1,600	0.20	3,200	0.20
D423TX-5-12.5	12.5	3,075	0.20	3,075	0.20	3,075	0.20	1,535	0.20	1,275	0.17	1,535	0.20	3,075	0.20
D423TX-5-13	13	2,950	0.21	2,950	0.21	2,950	0.21	1,475	0.21	1,250	0.18	1,475	0.21	2,950	0.21
D423TX-5-13.5	13.5	2,775	0.21	2,775	0.21	2,775	0.21	1,400	0.21	1,225	0.18	1,400	0.21	2,775	0.21
D423TX-5-14	14	2,700	0.22	2,700	0.22	2,700	0.22	1,350	0.22	1,200	0.18	1,350	0.22	2,700	0.22
D423TX-5-14.5	14.5	2,625	0.23	2,625	0.23	2,625	0.23	1,310	0.23	1,150	0.18	1,310	0.23	2,625	0.23
D423TX-5-15	15	2,550	0.24	2,550	0.24	2,550	0.24	1,275	0.24	1,100	0.19	1,275	0.24	2,550	0.24
D423TX-5-15.5	15.5	2,475	0.24	2,475	0.24	2,475	0.24	1,235	0.24	1,050	0.19	1,235	0.24	2,475	0.24
D423TX-5-16	16	2,400	0.25	2,400	0.25	2,400	0.25	1,200	0.25	1,000	0.20	1,200	0.25	2,400	0.25

1. Please work with good rigidity / high precision facilities and collet chuck.
2. Please choose proper cutting fluid.
3. The cutting data is reference value only. Please adjust it according to your real working conditions.
4. If RPM is lower the reference value, the Feed rate (fz) and RPM should be reduced by the same proportion.
5. If vibration occurs during cutting, please reduce cutting parameter.

D423TX-8

Oil-Feed High Performance Drills

Code No. D423TX-8-Dc

MG
CarbideAlTiSiN
TX

Work Material

P	H	M	K	N	S
●	●	●	●	○	○

P	Steel
---	-------

H	<38HRC Hardened Steel
---	--------------------------

H	<48HRC Hardened Steel
---	--------------------------

H	<56HRC Hardened Steel
---	--------------------------

M	Stainless Steel
---	-----------------

K	Cast Iron
---	-----------

S	Titanium
---	----------

S	Nickel
---	--------

S	High Temp Alloys
---	------------------

Feature of product:

JIS 8XD Drills with Oil-Feed
140° S-shape drill tip design to
reduce axial force.

Design with groove shape to
provide higher chip removal rates.

Good wear resistance and
lubrication with Nano multilayer
coating.

Oil-feed design could reduce
temperature effectively and
increase chip removal rates
during cutting process.

Application for drilling with Steels
which is below HRC48, Cast Iron...
etc.

Suitable for drilling with 8XD
depth.



Dc h7	Lc mm	L mm	d h6	AlTiSiN D423TX-8
2	24	76	3	●
2.1	28	80	3	●
2.2	28	80	3	●
2.3	28	80	3	●
2.4	28	80	3	●
2.5	28	80	3	●
2.6	31	80	3	●
2.7	31	80	3	●
2.8	31	80	3	●
2.9	31	80	3	●
3	31	80	3	●
3.1	39	95	4	●
3.2	39	95	4	●
3.3	39	95	4	●
3.4	39	95	4	●
3.5	39	95	4	●
3.6	44	95	4	●
3.7	44	95	4	●
3.8	44	95	4	●
3.9	44	95	4	●
4	44	95	4	●
4.1	50	105	5	●
4.2	50	105	5	●
4.3	50	105	5	●
4.4	50	105	5	●
4.5	50	105	5	●
4.6	55	105	5	●
4.7	55	105	5	●
4.8	55	105	5	●
4.9	55	105	5	●
5	55	105	5	●
5.1	61	118	6	●
5.2	61	118	6	●
5.3	61	118	6	●
5.4	61	118	6	●
5.5	61	118	6	●
5.6	66	118	6	●
5.7	66	118	6	●
5.8	66	118	6	●
5.9	66	118	6	●
6	66	118	6	●
6.1	72	130	7	●
6.2	72	130	7	●
6.3	72	130	7	●
6.4	72	130	7	●
6.5	72	130	7	●
6.6	77	130	7	●
6.7	77	130	7	●
6.8	77	130	7	●
6.9	77	130	7	●
7	77	130	7	●
7.1	83	142	8	●
7.2	83	142	8	●
7.3	83	142	8	●
7.4	83	142	8	●
7.5	83	142	8	●

Dc h7	Lc mm	L mm	d h6	AlTiSiN D423TX-8
7.6	88	142	8	●
7.7	88	142	8	●
7.8	88	142	8	●
7.9	88	142	8	●
8	88	142	8	●
8.1	94	154	9	●
8.2	94	154	9	●
8.3	94	154	9	●
8.4	94	154	9	●
8.5	94	154	9	●
8.6	99	154	9	●
8.7	99	154	9	●
8.8	99	154	9	●
8.9	99	154	9	●
9	99	154	9	●
9.1	105	166	10	●
9.2	105	166	10	●
9.3	105	166	10	●
9.4	105	166	10	●
9.5	105	166	10	●
9.6	110	166	10	●
9.7	110	166	10	●
9.8	110	166	10	●
9.9	110	166	10	●
10	110	166	10	●
10.1	116	182	11	●
10.2	116	182	11	●
10.3	116	182	11	●
10.4	116	182	11	●
10.5	116	182	11	●
10.6	121	182	11	●
10.7	121	182	11	●
10.8	121	182	11	●
10.9	121	182	11	●
11	121	182	11	●
11.1	127	194	12	●
11.2	127	194	12	●
11.3	127	194	12	●
11.4	127	194	12	●
11.5	127	194	12	●
11.6	132	194	12	●
11.7	132	194	12	●
11.8	132	194	12	●
11.9	132	194	12	●
12	132	194	12	●
12.5	138	206	13	●
13	143	206	13	●
13.5	149	218	14	●
14	154	218	14	●
14.5	160	230	15	●
15	165	230	15	●
15.5	171	242	16	●
16	176	242	16	●

Borehole parameters

Work Material		GR.1 Carbon Steel		GR.2 Low-alloyed Steel (~24HRC)		GR.3 Hi-alloyed Steel (~30HRC)		GR.4 Hardened Steel (30~38HRC)		GR.5 Hardened Steel (38~48HRC)		GR.8 Stainless Steel		GR.9 Cast Iron	
Vc m/min		80~150		80~150		80~150		40~70		32~50		50~80		80~150	
Code No.	Dc	RPM (min-1)	Feed (mm/rev)	RPM (min-1)	Feed (mm/rev)	RPM (min-1)	Feed (mm/rev)	RPM (min-1)	Feed (mm/rev)	RPM (min-1)	Feed (mm/rev)	RPM (min-1)	Feed (mm/rev)	RPM (min-1)	Feed (mm/rev)
D423TX-8-2	2	19,000	0.07	19,000	0.07	19,000	0.07	9,550	0.07	7,960	0.05	9,550	0.07	19,000	0.07
D423TX-8-2.5	2.5	15,300	0.08	15,300	0.08	15,300	0.08	7,600	0.08	6,370	0.06	7,650	0.08	15,300	0.08
D423TX-8-3	3	13,000	0.09	13,000	0.09	13,000	0.09	6,400	0.09	5,300	0.07	6,300	0.09	13,000	0.09
D423TX-8-3.5	3.5	11,250	0.09	11,250	0.09	11,250	0.09	5,600	0.09	4,600	0.07	5,500	0.09	11,250	0.09
D423TX-8-4	4	9,500	0.10	9,500	0.10	9,500	0.10	4,800	0.10	4,000	0.08	4,700	0.10	9,500	0.10
D423TX-8-4.5	4.5	8,550	0.11	8,550	0.11	8,550	0.11	4,300	0.11	3,600	0.09	4,250	0.11	8,550	0.11
D423TX-8-5	5	7,600	0.12	7,600	0.12	7,600	0.12	3,800	0.12	3,200	0.10	3,800	0.12	7,600	0.12
D423TX-8-5.5	5.5	7,000	0.13	7,000	0.13	7,000	0.13	3,500	0.13	2,900	0.11	3,500	0.13	7,000	0.13
D423TX-8-6	6	6,400	0.14	6,400	0.14	6,400	0.14	3,200	0.14	2,650	0.12	3,200	0.14	6,400	0.14
D423TX-8-6.5	6.5	6,000	0.14	6,000	0.14	6,000	0.14	3,000	0.14	2,450	0.12	3,000	0.14	6,000	0.14
D423TX-8-7	7	5,600	0.15	5,600	0.15	5,600	0.15	2,800	0.15	1,300	0.13	2,800	0.15	5,600	0.15
D423TX-8-7.5	7.5	5,200	0.15	5,200	0.15	5,200	0.15	2,600	0.15	1,250	0.13	2,600	0.15	5,200	0.15
D423TX-8-8	8	4,800	0.16	4,800	0.16	4,800	0.16	2,400	0.16	2,000	0.14	2,400	0.16	4,800	0.16
D423TX-8-8.5	8.5	4,550	0.16	4,550	0.16	4,550	0.16	2,275	0.16	1,900	0.14	2,275	0.16	4,550	0.16
D423TX-8-9	9	4,300	0.17	4,300	0.17	4,300	0.17	2,150	0.17	1,800	0.15	2,150	0.17	4,300	0.17
D423TX-8-9.5	9.5	4,050	0.17	4,050	0.17	4,050	0.17	2,025	0.17	1,700	0.15	2,025	0.17	4,050	0.17
D423TX-8-10	10	3,800	0.18	3,800	0.18	3,800	0.18	1,900	0.18	1,600	0.15	1,900	0.18	3,800	0.18
D423TX-8-10.5	10.5	3,650	0.18	3,650	0.18	3,650	0.18	1,825	0.18	1,525	0.15	1,825	0.18	3,650	0.18
D423TX-8-11	11	3,500	0.19	3,500	0.19	3,500	0.19	1,750	0.19	1,450	0.16	1,750	0.19	3,500	0.19
D423TX-8-11.5	11.5	3,350	0.19	3,350	0.19	3,350	0.19	1,675	0.19	1,375	0.16	1,675	0.19	3,350	0.19
D423TX-8-12	12	3,200	0.20	3,200	0.20	3,200	0.20	1,600	0.20	1,300	0.17	1,600	0.20	3,200	0.20
D423TX-8-12.5	12.5	3,075	0.20	3,075	0.20	3,075	0.20	1,535	0.20	1,275	0.17	1,535	0.20	3,075	0.20
D423TX-8-13	13	2,950	0.21	2,950	0.21	2,950	0.21	1,475	0.21	1,250	0.18	1,475	0.21	2,950	0.21
D423TX-8-13.5	13.5	2,775	0.21	2,775	0.21	2,775	0.21	1,400	0.21	1,225	0.18	1,400	0.21	2,775	0.21
D423TX-8-14	14	2,700	0.22	2,700	0.22	2,700	0.22	1,350	0.22	1,200	0.18	1,350	0.22	2,700	0.22
D423TX-8-14.5	14.5	2,625	0.23	2,625	0.23	2,625	0.23	1,310	0.23	1,150	0.18	1,310	0.23	2,625	0.23
D423TX-8-15	15	2,550	0.24	2,550	0.24	2,550	0.24	1,275	0.24	1,100	0.19	1,275	0.24	2,550	0.24
D423TX-8-15.5	15.5	2,475	0.24	2,475	0.24	2,475	0.24	1,235	0.24	1,050	0.19	1,235	0.24	2,475	0.24
D423TX-8-16	16	2,400	0.25	2,400	0.25	2,400	0.25	1,200	0.25	1,000	0.20	1,200	0.25	2,400	0.25

1. Please work with good rigidity / high precision facilities and collet chuck.
2. Please choose proper cutting fluid.
3. The cutting data is reference value only. Please adjust it according to your real working conditions.
4. If RPM is lower the reference value, the Feed rate (fz) and RPM should be reduced by the same proportion.
5. If vibration occurs during cutting, please reduce cutting parameter.

D423TX-12 / 16

Oil-Feed High Performance Drills

MG Carbide

AlTiSiN TX

12XD
16XD

2

138°

Work Material

P	H	M	K	N	S
●	●	●	●	○	○

P Steel

H <38HRC Hardened Steel

H <48HRC Hardened Steel

H <56HRC Hardened Steel

M Stainless Steel

K Cast Iron

S Titanium

S Nickel

S High Temp Alloys

Feature of product:
 D423TX-12 JIS I2XD Drills with Oil-Feed
 Suitable for drilling with I2XD depth.
 D423TX-16 JIS I6XD Drills with Oil-Feed
 Suitable for drilling with I6XD depth.
 I38° S-shape drill tip design to reduce axial force.
 Design with groove shape to provide higher chip removal rates.
 Good wear resistance and lubrication with Nano multilayer coating.
 Oil-feed design could reduce temperature effectively and increase chip removal rates during cutting process.
 Application for drilling with Steels which is below HRC48, Cast Iron... etc.



Code No. D423TX-12-Dc
D423TX-16-Dc

Dc	Lc	L	d	12XD	Dc	Lc	L	d	16XD
h7	mm	mm	h6	D423TX-12	h7	mm	mm	h6	D423TX-16
3	51	99	3	●	3	60	108	3	●
3.1	60	108	4	●	3.1	70	118	4	●
3.2	60	108	4	●	3.2	70	118	4	●
3.3	60	108	4	●	3.3	70	118	4	●
3.4	60	108	4	●	3.4	70	118	4	●
3.5	60	108	4	●	3.5	70	118	4	●
3.6	68	116	4	●	3.6	80	128	4	●
3.7	68	116	4	●	3.7	80	128	4	●
3.8	68	116	4	●	3.8	80	128	4	●
3.9	68	116	4	●	3.9	80	128	4	●
4	68	116	4	●	4	80	128	4	●
4.1	77	127	5	●	4.1	90	140	5	●
4.2	77	127	5	●	4.2	90	140	5	●
4.3	77	127	5	●	4.3	90	140	5	●
4.4	77	127	5	●	4.4	90	140	5	●
4.5	77	127	5	●	4.5	90	140	5	●
4.6	85	135	5	●	4.6	100	150	5	●
4.7	85	135	5	●	4.7	100	150	5	●
4.8	85	135	5	●	4.8	100	150	5	●
4.9	85	135	5	●	4.9	100	150	5	●
5	85	135	5	●	5	100	150	5	●
5.1	94	146	6	●	5.1	110	162	6	●
5.2	94	146	6	●	5.2	110	162	6	●
5.3	94	146	6	●	5.3	110	162	6	●
5.4	94	146	6	●	5.4	110	162	6	●
5.5	94	146	6	●	5.5	110	162	6	●
5.6	102	154	6	●	5.6	120	172	6	●
5.7	102	154	6	●	5.7	120	172	6	●
5.8	102	154	6	●	5.8	120	172	6	●
5.9	102	154	6	●	5.9	120	172	6	●
6	102	154	6	●	6	120	172	6	●
6.1	111	164	7	●	6.1	130	183	7	●
6.2	111	164	7	●	6.2	130	183	7	●
6.3	111	164	7	●	6.3	130	183	7	●
6.4	111	164	7	●	6.4	130	183	7	●
6.5	111	164	7	●	6.5	130	183	7	●
6.6	119	172	7	●	6.6	140	193	7	●
6.7	119	172	7	●	6.7	140	193	7	●
6.8	119	172	7	●	6.8	140	193	7	●
6.9	119	172	7	●	6.9	140	193	7	●
7	119	172	7	●	7	140	193	7	●
7.1	128	182	8	●	7.1	150	204	8	●
7.2	128	182	8	●	7.2	150	204	8	●
7.3	128	182	8	●	7.3	150	204	8	●
7.4	128	182	8	●	7.4	150	204	8	●
7.5	128	182	8	●	7.5	150	204	8	●
7.6	136	190	8	●	7.6	160	214	8	●
7.7	136	190	8	●	7.7	160	214	8	●
7.8	136	190	8	●	7.8	160	214	8	●
7.9	136	190	8	●	7.9	160	214	8	●
8	136	190	8	●	8	160	214	8	●
8.5	145	200	9	●	8.5	170	225	9	●
9	153	208	9	●	9	180	235	9	●
9.5	162	218	10	●	9.5	190	246	10	●
10	170	226	10	●	10	200	256	10	●
10.5	179	240	11	●	10.5	210	271	11	●
11	187	248	11	●	11	220	281	11	●
11.5	196	258	12	●	11.5	230	292	12	●
12	204	266	12	●	12	240	302	12	●

Borehole parameters

Work Material		GR.1 Carbon Steel		GR.2 Low-alloyed Steel (~24HRC)		GR.3 Hi-alloyed Steel (~30HRC)		GR.4 Hardened Steel (30~38HRC)		GR.8 Stainless Steel		GR.9 Cast Iron	
Vc m/min		60~125		60~125		60~125		40~80		40~80		50~80	
Code No.	Dc	RPM (min-1)	Feed (mm/rev)	RPM (min-1)	Feed (mm/rev)	RPM (min-1)	Feed (mm/rev)	RPM (min-1)	Feed (mm/rev)	RPM (min-1)	Feed (mm/rev)	RPM (min-1)	Feed (mm/rev)
D423TX-12-16-3	3	7,500	0.06	7,500	0.06	7,500	0.06	5,300	0.06	5,300	0.06	5,300	0.06
D423TX-12-16-3.5	3.5	6,950	0.07	6,950	0.07	6,950	0.07	5,150	0.07	5,150	0.07	5,150	0.07
D423TX-12-16-4	4	6,400	0.08	6,400	0.08	6,400	0.08	5,000	0.08	5,000	0.08	5,000	0.08
D423TX-12-16-4.5	4.5	6,100	0.09	6,100	0.09	6,100	0.09	4,750	0.09	4,750	0.09	4,750	0.09
D423TX-12-16-5	5	5,800	0.10	5,800	0.10	5,800	0.10	4,500	0.10	4,500	0.10	4,500	0.10
D423TX-12-16-5.5	5.5	5,300	0.11	5,300	0.11	5,300	0.11	4,150	0.11	4,150	0.11	4,150	0.11
D423TX-12-16-6	6	4,800	0.12	4,800	0.12	4,800	0.12	3,800	0.12	3,800	0.12	3,800	0.12
D423TX-12-16-6.5	6.5	4,500	0.13	4,500	0.13	4,500	0.13	3,550	0.13	3,550	0.13	3,550	0.13
D423TX-12-16-7	7	4,200	0.14	4,200	0.14	4,200	0.14	3,300	0.14	3,300	0.14	3,300	0.14
D423TX-12-16-7.5	7.5	3,900	0.15	3,900	0.15	3,900	0.15	3,050	0.15	3,050	0.15	3,050	0.15
D423TX-12-16-8	8	3,600	0.16	3,600	0.16	3,600	0.16	2,800	0.16	2,800	0.16	2,800	0.16
D423TX-12-16-8.5	8.5	3,410	0.17	3,410	0.17	3,410	0.17	2,675	0.17	2,675	0.17	2,675	0.17
D423TX-12-16-9	9	3,250	0.18	3,250	0.18	3,250	0.18	2,550	0.18	2,550	0.18	2,550	0.18
D423TX-12-16-9.5	9.5	3,060	0.19	3,060	0.19	3,060	0.19	2,425	0.19	2,425	0.19	2,425	0.19
D423TX-12-16-10	10	2,900	0.20	2,900	0.20	2,900	0.20	2,300	0.20	2,300	0.20	2,300	0.20
D423TX-12-16-10.5	10.5	2,775	0.21	2,775	0.21	2,775	0.21	2,200	0.21	2,200	0.21	2,200	0.21
D423TX-12-16-11	11	2,650	0.22	2,650	0.22	2,650	0.22	2,100	0.22	2,100	0.22	2,100	0.22
D423TX-12-16-11.5	11.5	2,525	0.23	2,525	0.23	2,525	0.23	2,000	0.23	2,000	0.23	2,000	0.23
D423TX-12-16-12	12	2,400	0.24	2,400	0.24	2,400	0.24	1,900	0.24	1,900	0.24	1,900	0.24

1. Please work with good rigidity / high precision facilities and collet chuck.
2. Please choose proper cutting fluid.
3. The cutting data is reference value only. Please adjust it according to your real working conditions.
4. If RPM is lower the reference value, the Feed rate (fz) and RPM should be reduced by the same proportion.
5. If vibration occurs during cutting, please reduce cutting parameter.

D423TX-20 / 25 / 30

Oil-Feed High Performance Drills

MG Carbide

AlTiSiN TX

20XD
25XD
30XD

2

20X138°
>25X135°

Work Material

P	H	M	K	N	S
●	●	●	●	○	○

P	Steel
H	<38HRC Hardened Steel
H	<48HRC Hardened Steel
H	<56HRC Hardened Steel
M	Stainless Steel
K	Cast Iron
S	Titanium
S	Nickel
S	High Temp Alloys

Feature of product:
 D423TX-20 JIS 20XD Drills with Oil-Feed
 Suitable for drilling with 20XD depth.
 D423TX-25 JIS 25XD Drills with Oil-Feed
 Suitable for drilling with 25XD depth.
 D423TX-30 JIS 30XD Drills with Oil-Feed
 Suitable for drilling with 30XD depth.
 135° S-shape drill tip design to reduce axial force.
 Design with groove shape to provide higher chip removal rates.
 Good wear resistance and lubrication with Nano multilayer coating.
 Oil-feed design could reduce temperature effectively and increase chip removal rates during cutting process.
 Application for drilling with Steels which is below HRC48, Cast Iron... etc.



Dc	Lc	L	d	20XD
h7	mm	mm	h6	D423TX-20
3	75	123	3	●
3.1	88	136	4	●
3.2	88	136	4	●
3.3	88	136	4	●
3.4	88	136	4	●
3.5	88	136	4	●
3.6	100	148	4	●
3.7	100	148	4	●
3.8	100	148	4	●
3.9	100	148	4	●
4	100	148	4	●
4.1	113	163	5	●
4.2	113	163	5	●
4.3	113	163	5	●
4.4	113	163	5	●
4.5	113	163	5	●
4.6	125	175	5	●
4.7	125	175	5	●
4.8	125	175	5	●
4.9	125	175	5	●
5	125	175	5	●
5.1	140	192	6	●
5.2	140	192	6	●
5.3	140	192	6	●
5.4	140	192	6	●
5.5	140	192	6	●
5.6	150	202	6	●
5.7	150	202	6	●
5.8	150	202	6	●
5.9	150	202	6	●
6	150	202	6	●
6.1	163	216	7	●
6.2	163	216	7	●
6.3	163	216	7	●
6.4	163	216	7	●
6.5	163	216	7	●
6.6	175	228	7	●
6.7	175	228	7	●
6.8	175	228	7	●
6.9	175	228	7	●
7	175	228	7	●
7.1	188	242	8	●
7.2	188	242	8	●
7.3	188	242	8	●
7.4	188	242	8	●
7.5	188	242	8	●
7.6	200	254	8	●
7.7	200	254	8	●
7.8	200	254	8	●
7.9	200	254	8	●
8	200	254	9	●
8.5	213	268	9	●
9	225	280	9	●
9.5	238	294	10	●
10	250	306	10	●

Code No. D423TX-20-Dc
D423TX-25-Dc

Dc	Lc	L	d	25XD
h7	mm	mm	h6	D423TX-25
3	90	138	3	●
3.5	105	153	4	●
4	120	168	4	●
4.5	135	185	5	●
5	150	200	5	●
5.5	165	217	6	●
6	180	232	6	●
6.5	195	248	7	●
7	210	263	7	●
7.5	225	279	8	●
8	240	294	8	●

Code No. D423TX-30-Dc

Dc	Lc	L	d	30XD
h7	mm	mm	h6	D423TX-30
3	105	153	3	●
3.5	123	171	4	●
4	140	188	4	●
4.5	158	208	5	●
5	175	225	5	●
5.5	193	245	6	●
6	210	262	6	●
6.5	228	281	7	●
7	245	298	7	●
7.5	263	317	8	●
8	280	334	8	●

Borehole parameters

Work Material		GR.1 Carbon Steel		GR.2 Low-alloyed Steel (~24HRC)		GR.3 Hi-alloyed Steel (~30HRC)		GR.4 Hardened Steel (30-38HRC)		GR.8 Stainless Steel		GR.9 Cast Iron	
Vc m/min		60~125		60~125		60~125		40~80		40~80		50~80	
Code No.	Dc	RPM (min-1)	Feed (mm/rev)	RPM (min-1)	Feed (mm/rev)	RPM (min-1)	Feed (mm/rev)	RPM (min-1)	Feed (mm/rev)	RPM (min-1)	Feed (mm/rev)	RPM (min-1)	Feed (mm/rev)
D423TX-20-25-30-3	3	7,500	0.06	7,500	0.06	7,500	0.06	5,300	0.06	5,300	0.06	5,300	0.06
D423TX-20-25-30-3.5	3.5	6,950	0.07	6,950	0.07	6,950	0.07	5,150	0.07	5,150	0.07	5,150	0.07
D423TX-20-25-30-4	4	6,400	0.08	6,400	0.08	6,400	0.08	5,000	0.08	5,000	0.08	5,000	0.08
D423TX-20-25-30-4.5	4.5	6,100	0.09	6,100	0.09	6,100	0.09	4,750	0.09	4,750	0.09	4,750	0.09
D423TX-20-25-30-5	5	5,800	0.10	5,800	0.10	5,800	0.10	4,500	0.10	4,500	0.10	4,500	0.10
D423TX-20-25-30-5.5	5.5	5,300	0.11	5,300	0.11	5,300	0.11	4,150	0.11	4,150	0.11	4,150	0.11
D423TX-20-25-30-6	6	4,800	0.12	4,800	0.12	4,800	0.12	3,800	0.12	3,800	0.12	3,800	0.12
D423TX-20-25-30-6.5	6.5	4,500	0.13	4,500	0.13	4,500	0.13	3,550	0.13	3,550	0.13	3,550	0.13
D423TX-20-25-30-7	7	4,200	0.14	4,200	0.14	4,200	0.14	3,300	0.14	3,300	0.14	3,300	0.14
D423TX-20-25-30-7.5	7.5	3,900	0.15	3,900	0.15	3,900	0.15	3,050	0.15	3,050	0.15	3,050	0.15
D423TX-20-25-30-8	8	3,600	0.16	3,600	0.16	3,600	0.16	2,800	0.16	2,800	0.16	2,800	0.16
D423TX-20-25-30-8.5	8.5	3,410	0.17	3,410	0.17	3,410	0.17	2,675	0.17	2,675	0.17	2,675	0.17
D423TX-20-25-30-9	9	3,250	0.18	3,250	0.18	3,250	0.18	2,550	0.18	2,550	0.18	2,550	0.18
D423TX-20-25-30-9.5	9.5	3,060	0.19	3,060	0.19	3,060	0.19	2,425	0.19	2,425	0.19	2,425	0.19
D423TX-20-25-30-10	10	2,900	0.20	2,900	0.20	2,900	0.20	2,300	0.20	2,300	0.20	2,300	0.20
D423TX-20-25-30-10.5	10.5	2,775	0.21	2,775	0.21	2,775	0.21	2,200	0.21	2,200	0.21	2,200	0.21
D423TX-20-25-30-11	11	2,650	0.22	2,650	0.22	2,650	0.22	2,100	0.22	2,100	0.22	2,100	0.22
D423TX-20-25-30-11.5	11.5	2,525	0.23	2,525	0.23	2,525	0.23	2,000	0.23	2,000	0.23	2,000	0.23
D423TX-20-25-30-12	12	2,400	0.24	2,400	0.24	2,400	0.24	1,900	0.24	1,900	0.24	1,900	0.24

1. Please work with good rigidity / high precision facilities and collet chuck.
2. Please choose proper cutting fluid.
3. The cutting data is reference value only. Please adjust it according to your real working conditions.
4. If RPM is lower the reference value, the Feed rate (fz) and RPM should be reduced by the same proportion.
5. If vibration occurs during cutting, please reduce cutting parameter.

D425TX-2

Flat Bottom Drills

Code No. D425TX-2-Dc

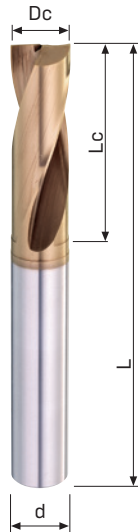
MG
CarbideAlTiSiN
TX

Dc	Lc	L	d	AlTiSiN
h7	mm	mm	h6	D425TX-2

Dc	Lc	L	d	AlTiSiN
h7	mm	mm	h6	D425TX-2

Work Material

P	H	M	K	N	S
●	●	○	●	○	○

P	Steel
---	-------

H	<38HRC Hardened Steel
---	--------------------------

H	<48HRC Hardened Steel
---	--------------------------

M	Stainless Steel
---	-----------------

K	Cast Iron
---	-----------

S	Titanium
---	----------

S	Nickel
---	--------

S	High Temp Alloys
---	------------------

Feature of product:

With 0° point of drill tip, it can avoid shift or skewing during non-planar drilling such as countersinks, ramping, curved surface..etc.

With AlTiSiN coating type to have longer tool life and enhance cutting and using efficiency.

Dc	Lc	L	d	AlTiSiN	Dc	Lc	L	d	AlTiSiN
h7	mm	mm	h6	D425TX-2	h7	mm	mm	h6	D425TX-2
1	3	50	3	●	7	24	70	6	●
1.1	4	50	3	●	7.1	26	70	6	●
1.2	4	50	3	●	7.2	26	70	6	●
1.3	4	50	3	●	7.3	26	70	6	●
1.4	5	50	3	●	7.4	27	70	6	●
1.5	5	50	3	●	7.5	27	70	6	●
1.6	5	50	3	●	7.6	27	70	6	●
1.7	6	50	3	●	7.7	28	70	6	●
1.8	6	50	3	●	7.8	28	70	6	●
1.9	7	50	3	●	7.9	28	70	6	●
2	7	50	4	●	8	28	70	8	●
2.1	8	50	4	●	8.1	29	80	8	●
2.2	8	50	4	●	8.2	29	80	8	●
2.3	8	50	4	●	8.3	29	80	8	●
2.4	9	50	4	●	8.4	30	80	8	●
2.5	9	50	4	●	8.5	30	80	8	●
2.6	9	50	4	●	8.6	30	80	8	●
2.7	10	50	4	●	8.7	32	80	8	●
2.8	10	50	4	●	8.8	32	80	8	●
2.9	11	50	4	●	8.9	32	80	8	●
3	11	50	6	●	9	32	80	8	●
3.1	12	50	6	●	9.1	33	80	8	●
3.2	12	50	6	●	9.2	33	80	8	●
3.3	12	50	6	●	9.3	33	80	8	●
3.4	13	50	6	●	9.4	34	80	8	●
3.5	13	50	6	●	9.5	34	80	8	●
3.6	13	50	6	●	9.6	34	80	8	●
3.7	14	50	6	●	9.7	35	80	8	●
3.8	14	50	6	●	9.8	35	80	8	●
3.9	14	50	6	●	9.9	35	80	8	●
4	14	50	6	●	10	35	80	10	●
4.1	15	60	6	●	10.1	36	90	10	●
4.2	15	60	6	●	10.2	36	90	10	●
4.3	15	60	6	●	10.3	36	90	10	●
4.4	16	60	6	●	10.4	37	90	10	●
4.5	16	60	6	●	10.5	37	90	10	●
4.6	16	60	6	●	10.6	37	90	10	●
4.7	18	60	6	●	10.7	38	90	10	●
4.8	18	60	6	●	10.8	38	90	10	●
4.9	18	60	6	●	10.9	38	90	10	●
5	18	60	6	●	11	38	90	10	●
5.1	19	60	6	●	11.1	40	90	10	●
5.2	19	60	6	●	11.2	40	90	10	●
5.3	19	60	6	●	11.3	40	90	10	●
5.4	20	60	6	●	11.4	41	90	10	●
5.5	20	60	6	●	11.5	41	90	10	●
5.6	20	60	6	●	11.6	41	90	10	●
5.7	21	60	6	●	11.7	42	90	10	●
5.8	21	60	6	●	11.8	42	90	10	●
5.9	21	60	6	●	11.9	42	90	10	●
6	21	60	6	●	12	42	90	12	●
6.1	22	70	6	●	12.5	44	100	12	●
6.2	22	70	6	●	13	45	100	12	●
6.3	22	70	6	●	13.5	48	100	12	○
6.4	23	70	6	●	14	49	105	12	○
6.5	23	70	6	●	14.5	51	105	12	○
6.6	23	70	6	●	15	52	105	12	○
6.7	24	70	6	●	15.5	55	115	12	○
6.8	24	70	6	●	16	56	115	16	○
6.9	24	70	6	●					

※ Mark: ○, On request, no stock

Borehole parameters

Work Material		GR.1 Carbon Steel		GR.2 Low-alloyed Steel (~24HRC)		GR.3 Hi-alloyed Steel (~30HRC)		GR.8 Stainless Steel		GR.9 Cast Iron		GR.12 鋁合金 Aluminium	
Vc m/min		55~70		55~70		55~70		25~30		55~70		100~110	
Code No.	Dc	RPM [min-1]	Feed [mm/rev]	RPM [min-1]	Feed [mm/rev]	RPM [min-1]	Feed [mm/rev]	RPM [min-1]	Feed [mm/rev]	RPM [min-1]	Feed [mm/rev]	RPM [min-1]	Feed [mm/rev]
D425TX-2-1	1	18,000	450	14,300	358	12,700	318	7,900	55	18,000	450	31,800	636
D425TX-2-1.5	1.5	13,500	473	10,000	350	8,400	294	5,300	53	13,500	473	21,200	424
D425TX-2-2	2	9,500	380	7,900	316	6,700	268	4,700	71	9,500	380	17,500	875
D425TX-2-2.5	2.5	7,900	395	6,600	330	5,700	285	3,800	57	7,900	395	14,000	840
D425TX-2-3	3	7,900	474	7,900	474	6,800	408	3,100	186	7,900	474	11,600	696
D425TX-2-4	4	5,900	472	5,900	472	5,100	408	2,300	184	5,900	472	8,700	696
D425TX-2-5	5	4,700	470	4,700	470	4,100	410	1,900	190	4,700	470	7,000	700
D425TX-2-6	6	3,900	507	3,900	507	3,400	442	1,500	195	3,900	507	5,800	754
D425TX-2-7	7	3,400	476	3,400	476	3,000	420	1,300	182	3,400	476	5,100	740
D425TX-2-8	8	2,900	435	2,900	435	2,500	375	1,100	165	2,900	435	4,300	688
D425TX-2-9	9	2,600	416	2,600	416	2,250	360	1,000	160	2,600	416	3,900	780
D425TX-2-10	10	2,300	391	2,300	391	2,000	340	950	162	2,300	391	3,500	700
D425TX-2-11	11	2,100	378	2,100	378	1,800	324	850	153	2,100	378	3,100	682
D425TX-2-12	12	1,900	380	1,900	380	1,700	340	790	158	1,900	380	2,900	696
D425TX-2-13	13	1,800	360	1,800	360	1,600	320	740	148	1,800	360	2,700	675
D425TX-2-14	14	1,650	363	1,650	363	1,500	330	690	152	1,650	363	2,500	650
D425TX-2-15	15	1,500	345	1,500	345	1,400	322	640	147	1,500	345	2,300	621
D425TX-2-16	16	1,400	350	1,400	350	1,200	300	590	148	1,400	350	2,100	588
(mm)		ap:2.0D		ap:2.0D		ap:2.0D		ap:2.0D		ap:2.0D		ap:2.0	

1. Please work with good rigidity / high precision facilities and collet chuck.
2. Please choose proper cutting fluid.
3. The cutting data is reference value only. Please adjust it according to your real working conditions.
4. If RPM is lower the reference value, the Feed rate [fz] and RPM should be reduced by the same proportion.
5. If vibration occurs during cutting, please reduce cutting parameter.

Interchangeable Multi-purpose End Mill Cutter

1. Double-contact surface (taper and face)
2. Solid carbide cutter head and body shank
3. High accuracy, rigidity and efficiency in cutting
4. High economy value with various interchangeable cutter heads
5. Trapezoidal-designed thread reduces thread chipping
6. Runout within 5 μ m

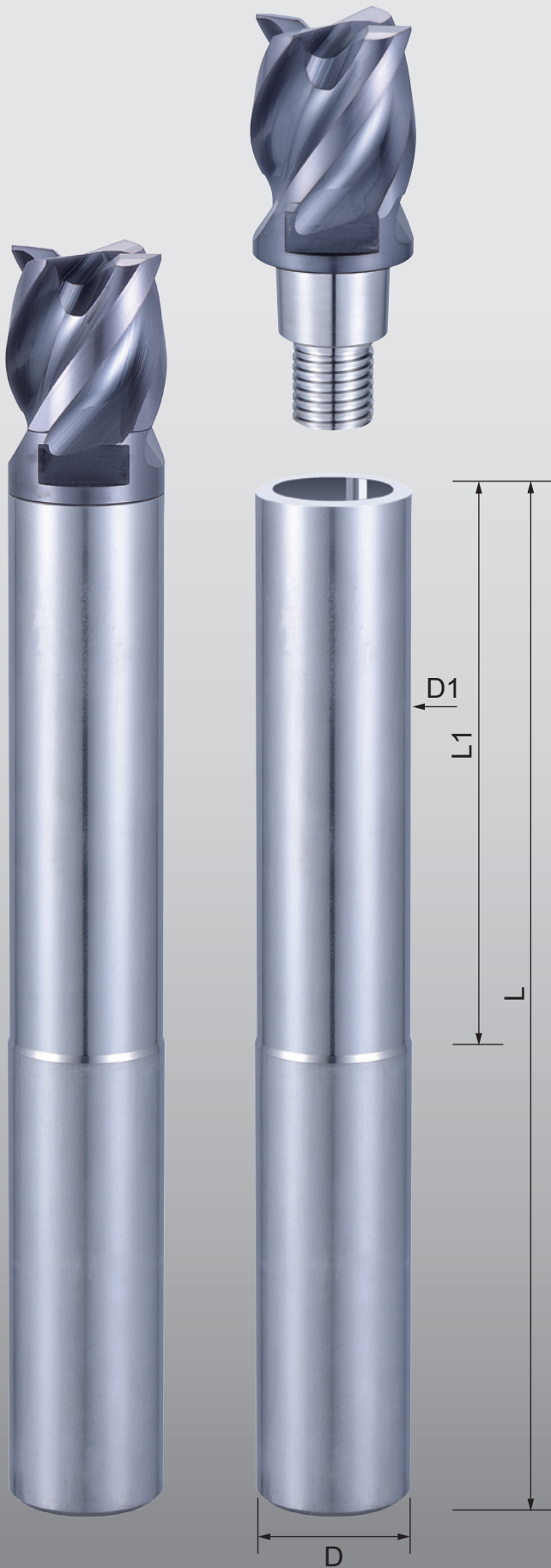

D×L×d1 (L1×D1)	Code No.	Price
10×70×2.0 (15×9.7)	EMH10U1007015	●
10×90×2.0 (30×9.7)	EMH10U1009030	●
10×110×2.0	EMH10S1011000	●
12×80×2.5 (18×11.7)	EMH12U1208018	●
12×100×2.5 (36×11.7)	EMH12U1210036	●
12×120×2.5	EMH12S1212000	●
16×90×3.5 (24×15.5)	EMH16U1609024	●
16×120×3.5 (48×15.5)	EMH16U1612048	●
16×150×3.5	EMH16S1615000	●
20×100×5.0 (30×19.5)	EMH20U2010030	●
20×130×5.0 (60×19.5)	EMH20U2013060	●
20×180×5.0	EMH20S2018000	●
25×110×5.0 (38×24.5)	EMH25U2511038	●
25×160×5.0 (75×24.5)	EMH25U2516075	●
25×210×5.0	EMH25S2521000	●

※ d1: coolant hole

E140HX

Multipurpose End Mills

MG Carbide
AlTiCrN HX





E140HX-Cutter

Code No.	Dc 0 -0.02	Lc mm	L1 mm	d1 mm	AlTiCrN HX
EMH10-SM10	10	11	16	9.7	●
EMH12-SM12	12	13	19	11.7	●
EMH16-SM16	16	17	25	15.5	●
EMH20-SM20	20	21	31	19.5	●
EMH25-SM25	25	26	39	24.5	●

Steel < 48HRC

P	H	M	K	N	S
●	●	●	●	○	○

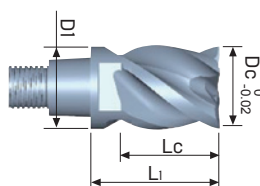



Work Material

P	Steel
H	<38HRC Hardened Steel
H	<48HRC Hardened Steel
H	<56HRC Hardened Steel
H	<68HRC Hardened Steel
M	Stainless Steel
K	Cast Iron
N	Aluminium
N	Copper
N	Plastics
N	FRP CFRP Composite Material
N	Graphite

E143

End Mills For Aluminium

MG Carbide
Uncoated Bright





E143-Cutter

Code No.	Dc 0 -0.02	Lc mm	L1 mm	d1 mm	Bright
EMH10-SA10	10	11	16	9.7	●
EMH12-SA12	12	13	19	11.7	●
EMH16-SA16	16	17	25	15.5	●
EMH20-SA20	20	21	31	19.5	●
EMH25-SA25	25	26	39	24.5	●

Aluminium

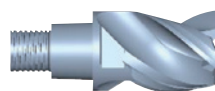



P	H	M	K	N	S
○	○	○	○	●	○



S	Titanium
S	Nickel
S	High Temp Alloys

E166TX

Finishing End Mills

SMG Carbide
AlTiSiN TX





E166TX-Cutter

Code No.	Dc 0 -0.02	Lc mm	L1 mm	d1 mm	AlTiSiN TX
EMH10-EF10	10	11	16	9.7	●
EMH12-EF12	12	13	19	11.7	●
EMH16-EF16	16	17	25	15.5	●
EMH20-EF20	20	21	31	19.5	●
EMH25-EF25	25	26	39	24.5	●



Hardened Steel 40-70HRC

P	H	M	K	N	S
○	●	○	○	○	○



B254TX

Ball Nose End Mills - 4 Flutes

SMG Carbide
AlTiSiN TX





B254TX-Cutter

Code No.	Dc 0 -0.02	R ±0.01	Lc mm	L1 mm	d1 mm	AlTiSiN TX
EMH10-BH10	10	5	11	16	9.7	●
EMH12-BH12	12	6	13	19	11.7	●
EMH16-BH16	16	8	17	25	15.5	●
EMH20-BH20	20	10	21	31	19.5	●
EMH25-BH25	25	12.5	26	39	24.5	●

Hardened Steel 40-70HRC

P	H	M	K	N	S
○	●	○	○	○	○



Interchangeable Blank Cutter Heads

Code No. EMH10-10027 / EMH12-1232 / EMH16-1642 / EMH20-2052 / EMH25-2565

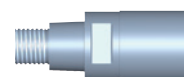

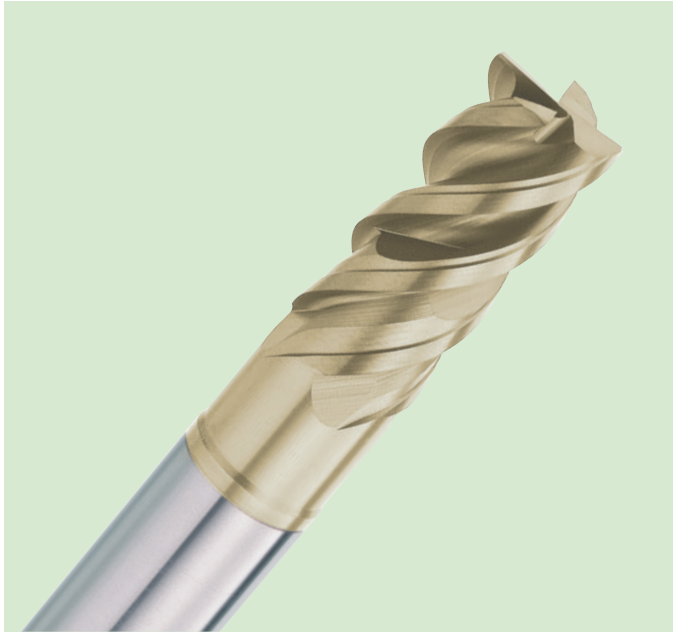

HF514SX Page. 217

Multipurpose End Mills With Coolant Hole

Design with high removal cutting geometry. Y-shape special oil-feed design can make cutting fluid act more directly on cutting point. Improved cutting edge strength for cutting different materials below 48HRC.

F524SX Page. 221

Premium Cut End Mills

Designed with two unequal flutes, 48° variable helix geometry.

Small edge cutting land with the relief angle, with better impact resistance.

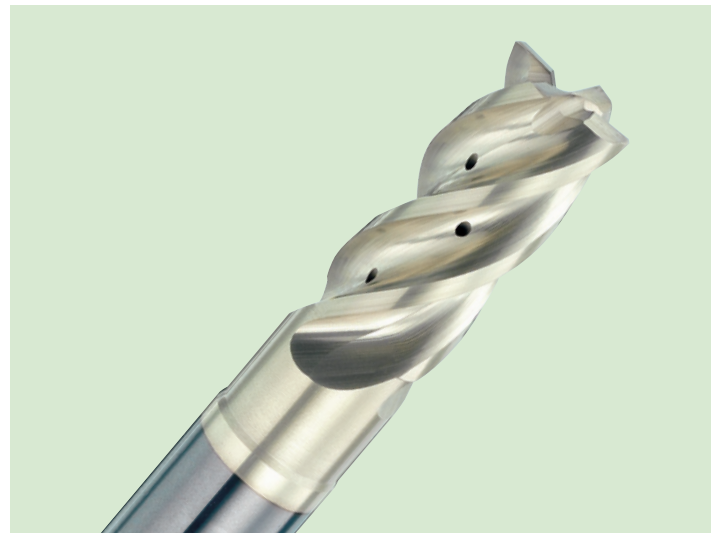

F631ZX Page. 235

End Mills For Aluminium

Designed with three variable helix, and three unequal flutes.

Sharp cutting edge and geometric design with high chip removal rate and anti-sticking.

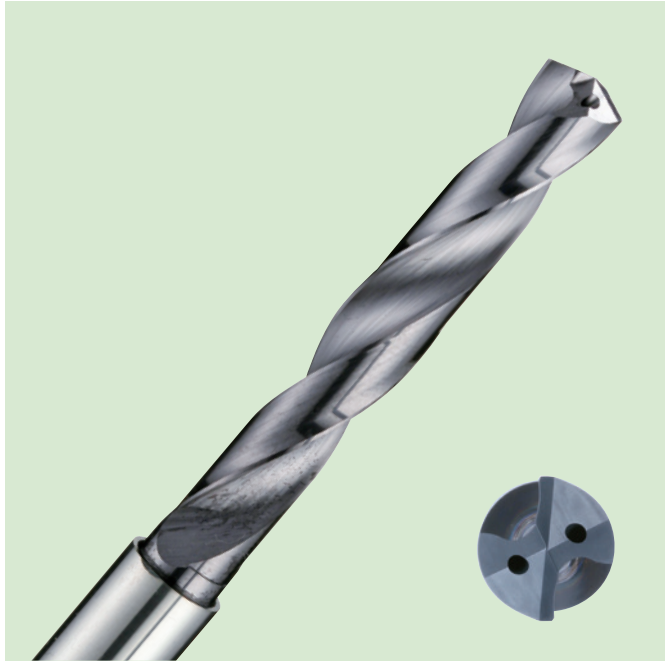

D436FT Page. 293

Oil-Feed High Performance Drills

140° S-type drill point design with centring and positioning function, reduce axial drilling force. Designed with high chip evacuating flutes. Oil-feed design for internal coolant supply.



R329 Page. 315

NC Machine Reamers Right Hand Helix

Designed with right helix and right cutting flutes.

Upward chip evacuation. Application for reaming different steels below 48HRC, cast iron...and etc.

R319 Page. 313

NC Machine Reamers







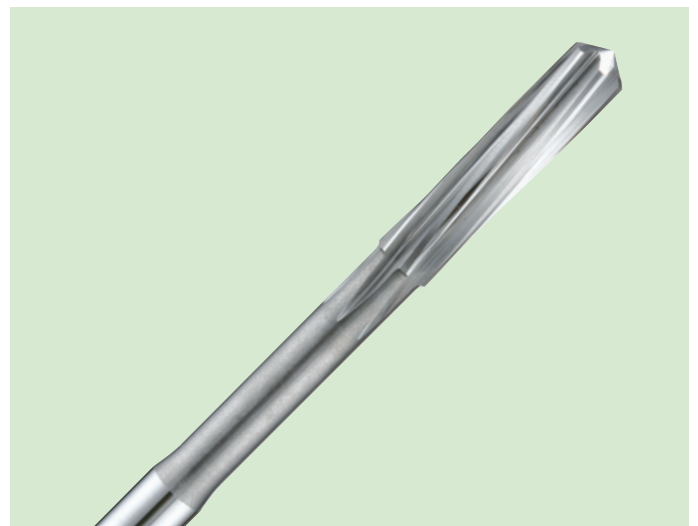







Designed with left helix and right cutting flutes.

Widely diameter specification from 0.98mm to 12.05mm in step of 0.01mm.

























Accuracy tolerance: 0/+0.004mm.



High Performance End Mills

Page	215	217	219	221	223	223
Apperance						
Code No	F513SX	HF514SX	F514SX F515SX	F524SX F525SX	F517TX F518TX	F636TX
Carbide	VHM Carbide	VHM Carbide	VHM Carbide	VHM Carbide	VHM Carbide	VHM Carbide
Coating	AlTiXN+ZrN SX	AlTiXN+ZrN SX	AlTiXN+ZrN SX	AlTiSiN TX	AlTiSiN TX	AlTiSiN TX
Helix Angle	 38° 41°	 38° 41°	 38° 41°	 48°	 42° 45°	 38° 41°
No.of Flutes	 3	 4	 4	 4	 4	 4

DIN

225	227	229	231	233	235	235	237	239	241
									
F608HX F609HX	F638TX F649TX	F651SX	F652SX	F653SX	F631ZX	F631 F632	F607ZX	F642ZX F643ZX	F618ZX F620ZX
VHM Carbide	VHM Carbide	VHM Carbide	VHM Carbide	VHM Carbide	VHM Carbide	VHM Carbide	VHM Carbide	VHM Carbide	VHM Carbide
AlTiCrN HX	AlTiSiN TX	AlTiXN+ZrN SX	AlTiXN+ZrN SX	AlTiXN+ZrN SX	ZrN ZX	Bright	ZrN ZX	ZrN ZX	ZrN ZX
 20°	 40° 42°	 38°	 38°	 38°	 40°	 40°	 40°	 40°	 40°
 4	 4	 4	 4	 5	 3	 3	 3	 3	 2

F513SX

Multipurpose End Mills

Designed with two variable helix geometry, three unequal flutes, sharp cutting edge, and high removal cutting geometry.

Good wear resistance and lubricating effect with Nano multilayer coating.

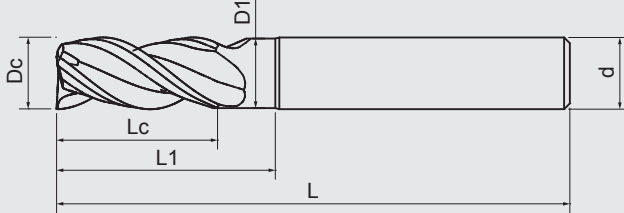

VHM
Carbide

AlTiXN+ZrN
SX



0.05-0.2
Steel
<48HRC

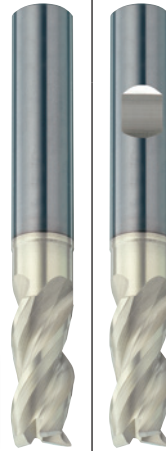

Sharp cutting edge recommended for stainless steel, as well for cutting different steels below 48HRC, such as cast iron.

Application for roughing and finishing cutting, drilling, and ramping.

Work on any cutting direction with high speed condition.

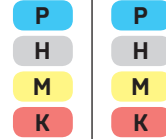

DIN 6527 Standard Length

Dc 0 -0.02	Lc mm	L mm	d h5	L1 mm	D1 mm	45° mm	F513SX HA	F513SX HB				
3	8	57	6	14	2.8	0.10	●	●				
4	11	57	6	16	3.8	0.10	●	●				
5	13	57	6	18	4.8	0.15	●	●				
6	13	57	6	20	5.8	0.15	●	●				
8	19	63	8	26	7.7	0.15	●	●				
10	22	72	10	31	9.7	0.20	●	●				
12	26	83	12	37	11.6	0.20	●	●				
14	26	83	14	37	13.5	0.20	●	●				
16	32	92	16	43	15.5	0.20	●	●				
18	32	92	18	47	17.5	0.20	●	●				
20	38	104	20	53	19.5	0.20	●	●				

Cutting Conditions

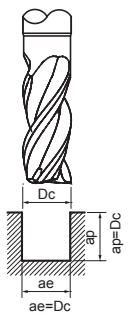
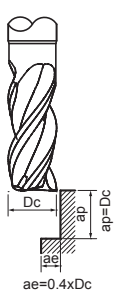
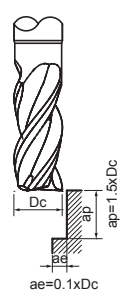
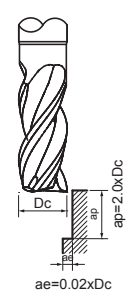
F513SX									
		cutting speed Vc (m/min)	feed per tooth fz (mm)	cutting speed Vc (m/min)	feed per tooth fz (mm)	cutting speed Vc (m/min)	feed per tooth fz (mm)	cutting speed Vc (m/min)	feed per tooth fz (mm)
Carbon Steel Materials									
P	GR1 Carbon Steel	120	0.006xDc	120	0.006xDc	130	0.006xDc	140	0.007xDc
	GR2 <24HRC Low-alloyed Steel	120	0.005xDc	120	0.005xDc	130	0.005xDc	140	0.006xDc
	GR3 <30HRC Hi-alloyed Steel	80	0.005xDc	80	0.005xDc	90	0.005xDc	100	0.006xDc
Hardened Steel Materials									
H	GR4 30-38HRC Hardened Steel	65	0.004xDc	90	0.003xDc	90	0.003xDc	100	0.003xDc
	GR5 38-48HRC Hardened Steel	60	0.003xDc	80	0.003xDc	80	0.003xDc	90	0.003xDc
Stainless Steel Materials									
M	GR8-1 Ferritic \ Martensitic	80	0.003xDc	90	0.004xDc	110	0.003xDc	130	0.003xDc
	GR8-2 Austenitic	70	0.003xDc	80	0.003xDc	90	0.003xDc	100	0.003xDc
	GR8-3 Austenitic-ferritic	40	0.002xDc	50	0.003xDc	90	0.002xDc	60	0.002xDc
	GR8-4 Austenitic-ferritic Heat-resistant	30	0.002xDc	40	0.003xDc	40	0.002xDc	50	0.002xDc
Cast Iron Materials									
K	GR9-1 Grey cast iron	110	0.006xDc	110	0.006xDc	120	0.006xDc	130	0.007xDc
	GR9-2 Nodular cast iron	120	0.006xDc	120	0.006xDc	130	0.006xDc	140	0.007xDc

1. Please work with good rigidity / high precision facilities and collet chuck.
2. Please choose proper cutting fluid.
3. The cutting data is reference value only. Please adjust it according to your real working conditions.
4. If RPM is lower the reference value, the Feed rate (fz) and RPM should be reduced by the same proportion.
5. If vibration occurs during cutting, please reduce cutting parameter.

HF514SX

Multipurpose End Mills With Coolant Hole

Designed with variable helix geometry, unequal flutes.

Have a good wear resistance and impact resistance.

Good wear resistance and lubricating effect with Nano ZrN multilayer coating.

With Y-shape special oil-feed design can make cutting fluid act more directly on cutting point to enhance chip removal rate.

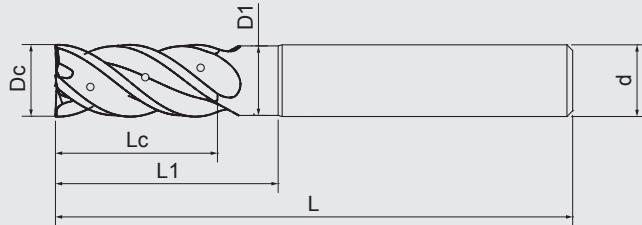

VHM
Carbide

AlTiXN+ZrN
SX



Steel
<48HRC

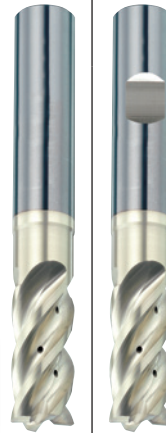

Suitable for cutting different steel below 48HRC as well as stainless steel and aluminium.

Application from roughing to finishing cutting, drilling, ramping... in different materials.



DIN 6527 Standard Length

Dc 0 -0.02	Lc mm	L mm	d h5	L1 mm	D1 mm	HF514SX HA	HF514SX HB				
6	13	57	6	20	5.8	●	●				
8	19	63	8	26	7.7	●	●				
10	22	72	10	31	9.7	●	●				
12	26	83	12	37	11.6	●	●				
16	32	92	16	43	15.5	●	●				
20	38	104	20	53	19.5	●	●				

Cutting Conditions

HF514SX									
		cutting speed Vc (m/min)	feed per tooth fz(mm)	cutting speed Vc (m/min)	feed per tooth fz(mm)	cutting speed Vc (m/min)	feed per tooth fz(mm)	cutting speed Vc (m/min)	feed per tooth fz(mm)
Carbon Steel Materials									
P	GR1 Carbon Steel	120	0.006xDc	120	0.006xDc	130	0.006xDc	140	0.007xDc
	GR2 <24HRC Low-alloyed Steel	120	0.005xDc	120	0.005xDc	130	0.005xDc	140	0.006xDc
	GR3 <30HRC Hi-alloyed Steel	80	0.005xDc	80	0.005xDc	90	0.005xDc	100	0.006xDc
Hardened Steel Materials									
H	GR4 30-38HRC Hardened Steel	65	0.004xDc	90	0.003xDc	90	0.003xDc	100	0.003xDc
	GR5 38-48HRC Hardened Steel	60	0.003xDc	80	0.003xDc	80	0.003xDc	90	0.003xDc
Stainless Steel Materials									
M	GR8-1 Ferritic \ Martensitic	80	0.003xDc	90	0.004xDc	110	0.003xDc	130	0.003xDc
	GR8-2 Austenitic	70	0.003xDc	80	0.003xDc	90	0.003xDc	100	0.003xDc
	GR8-3 Austenitic-ferritic	40	0.002xDc	50	0.003xDc	90	0.002xDc	60	0.002xDc
	GR8-4 Austenitic-ferritic Heat-resistant	30	0.002xDc	40	0.003xDc	40	0.002xDc	50	0.002xDc
Cast Iron Materials									
K	GR9-1 Grey cast iron	110	0.006xDc	110	0.006xDc	120	0.006xDc	130	0.007xDc
	GR9-2 Nodular cast iron	120	0.006xDc	120	0.006xDc	130	0.006xDc	140	0.007xDc

1. Please work with good rigidity / high precision facilities and collet chuck.
2. Please choose proper cutting fluid.
3. The cutting data is reference value only. Please adjust it according to your real working conditions.
4. If RPM is lower the reference value, the Feed rate (fz) and RPM should be reduced by the same proportion.
5. If vibration occurs during cutting, please reduce cutting parameter.

F514SX / F515SX

Multipurpose End Mills

Designed with variable helix geometry, unequal flutes.

Have a good wear resistance and impact resistance.

Good wear resistance and lubricating effect with Nano ZrN multilayer coating.

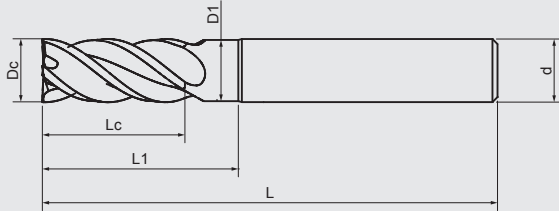

VHM
Carbide

AlTiXN+ZrN
SX



0.05-0.2
Steel
<48HRC

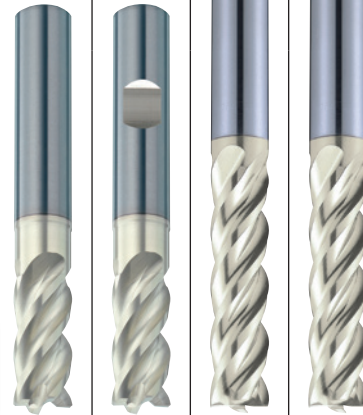

Suitable for cutting different steel below 48HRC as well as stainless steel and aluminium.

Application from roughing to finishing cutting, drilling, ramping... in different materials.

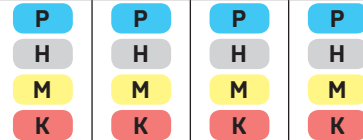

DIN 6527 Standard Length

Dc 0 -0.02	Lc mm	L mm	d h5	L1 mm	D1 mm	45° mm	F514SX HA	F514SX HB				
3	8	57	6	14	2.8	0.10	●	●				
4	11	57	6	16	3.8	0.10	●	●				
5	13	57	6	18	4.8	0.15	●	●				
6	13	57	6	20	5.8	0.15	●	●				
8	19	63	8	26	7.7	0.15	●	●				
10	22	72	10	31	9.7	0.20	●	●				
12	26	83	12	37	11.6	0.20	●	●				
14	26	83	14	37	13.5	0.20	●	●				
16	32	92	16	43	15.5	0.20	●	●				
18	32	92	18	43	17.5	0.20	●	●				
20	38	104	20	53	19.5	0.20	●	●				

Long Length

Dc 0 -0.02	Lc mm	L mm	d h5	L1 mm	D1 mm	45° mm			F515SX HA	F515SX HB		
6	19	63	6	26	5.8	0.15			●	●		
8	28	72	8	35	7.7	0.15			●	●		
10	34	84	10	43	9.7	0.20			●	●		
12	40	97	12	51	11.6	0.20			●	●		
16	48	108	16	59	15.5	0.20			●	●		
20	56	122	20	71	19.5	0.20			●	●		

Cutting Conditions

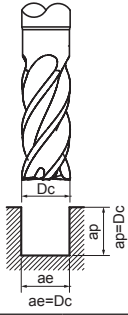
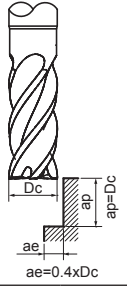
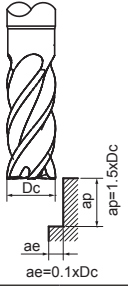
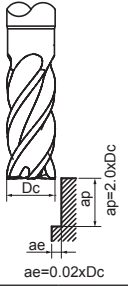
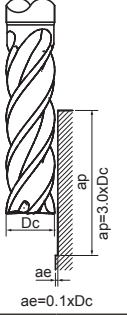
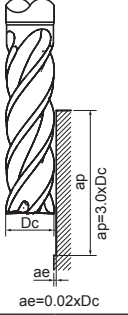
F514SX F515SX		F514SX		F514SX		F514SX		F514SX		F515SX		F515SX	
								cutting speed Vc (m/min)	feed per tooth fz(mm)	cutting speed Vc (m/min)	feed per tooth fz(mm)	cutting speed Vc (m/min)	feed per tooth fz(mm)
Carbon Steel Materials													
P	GR1 Carbon Steel	120	0.006xDc	120	0.006xDc	130	0.006xDc	140	0.007xDc	110	0.006xDc	120	0.006xDc
	GR2 <24HRC Low-alloyed Steel	120	0.005xDc	120	0.005xDc	130	0.005xDc	140	0.006xDc	110	0.005xDc	120	0.005xDc
	GR3 <30HRC Hi-alloyed Steel	80	0.005xDc	80	0.005xDc	90	0.005xDc	100	0.006xDc	70	0.005xDc	80	0.005xDc
Hardened Steel Materials													
H	GR4 30-38HRC Hardened Steel	65	0.004xDc	90	0.003xDc	90	0.003xDc	100	0.003xDc	90	0.004xDc	100	0.003xDc
	GR5 38-48HRC Hardened Steel	60	0.003xDc	80	0.003xDc	80	0.003xDc	90	0.003xDc	70	0.003xDc	80	0.003xDc
Stainless Steel Materials													
M	GR8-1 Ferritic \ Martensitic	80	0.003xDc	90	0.004xDc	110	0.003xDc	130	0.003xDc	70	0.003xDc	80	0.004xDc
	GR8-2 Austenitic	70	0.003xDc	80	0.003xDc	90	0.003xDc	100	0.003xDc	60	0.003xDc	70	0.003xDc
	GR8-3 Austenitic-ferritic	40	0.002xDc	50	0.003xDc	90	0.002xDc	60	0.002xDc	50	0.002xDc	60	0.003xDc
	GR8-4 Austenitic-ferritic Heat-resistant	30	0.002xDc	40	0.003xDc	40	0.002xDc	50	0.002xDc	40	0.002xDc	50	0.003xDc
Cast Iron Materials													
K	GR9-1 Grey cast iron	110	0.006xDc	110	0.006xDc	120	0.006xDc	130	0.007xDc	100	0.006xDc	110	0.005xDc
	GR9-2 Nodular cast iron	120	0.006xDc	120	0.006xDc	130	0.006xDc	140	0.007xDc	110	0.006xDc	120	0.005xDc

All cutting data serve for orientation only and should be adapted individually to the technical conditions on location

1. Please work with good rigidity / high precision facilities and collet chuck.
2. Please choose proper cutting fluid.
3. The cutting data is reference value only. Please adjust it according to your real working conditions.
4. If RPM is lower the reference value, the Feed rate (fz) and RPM should be reduced by the same proportion.
5. If vibration occurs during cutting, please reduce cutting parameter.

F524SX / F525SX

Premium Cut End Mills

Two unequal flutes, and small edge cutting land with the relief angle, with better impact resistance.
 Designed with high removal cutting geometry.
 The use of Si-silicon AlTiSiN coating has excellent wear resistance.

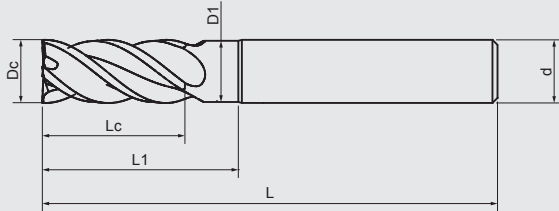

VHM Carbide	AlTiXN+ZrN SX	48°	4	78°	0.05-0.2 45°	Steel <48HRC
--------------------	----------------------	-----	---	-----	-----------------	------------------------

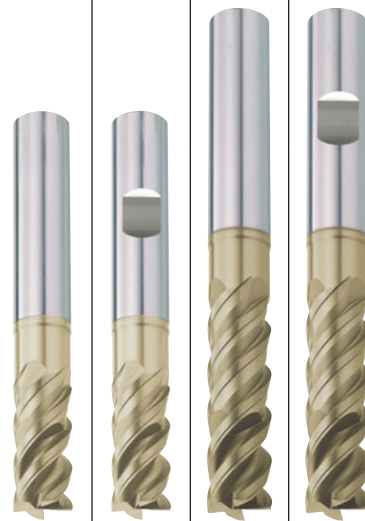

Improved cutting edge strength for cutting different materials below 48HRC, stainless steel, cast iron as well as aluminium.
 Application from roughing to finishing cutting, drilling, ramping... in different materials.

P	P	P	P
H	H	H	H
M	M	M	M
K	K	K	K

DIN 6527 Standard Length

Dc 0 -0.02	Lc mm	L mm	d h5	L1 mm	D1 mm	45° mm	F524SX HA	F524SX HB				
3	8	57	6	14	2.8	0.10	●	●				
4	11	57	6	16	3.8	0.10	●	●				
5	13	57	6	18	4.8	0.15	●	●				
6	13	57	6	20	5.8	0.15	●	●				
8	19	63	8	26	7.7	0.15	●	●				
10	22	72	10	31	9.7	0.20	●	●				
12	26	83	12	37	11.6	0.20	●	●				
14	26	83	14	37	13.5	0.20	●	●				
16	32	92	16	43	15.5	0.20	●	●				
18	32	92	18	43	17.5	0.20	●	●				
20	38	104	20	53	19.5	0.20	●	●				

Long Length

Dc 0 -0.02	Lc mm	L mm	d h5	L1 mm	D1 mm	45° mm			F525SX HA	F525SX HB		
6	19	63	6	26	5.8	0.15			●	●		
8	28	72	8	35	7.7	0.15			●	●		
10	34	84	10	43	9.7	0.20			●	●		
12	40	97	12	51	11.6	0.20			●	●		
16	48	108	16	59	15.5	0.20			●	●		
20	56	122	20	71	19.5	0.20			●	●		

Cutting Conditions

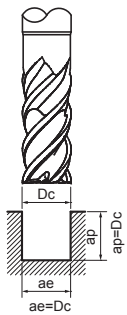
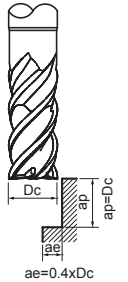
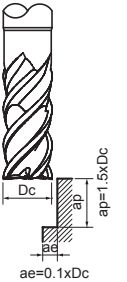
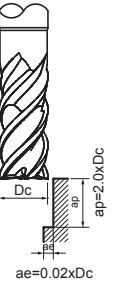
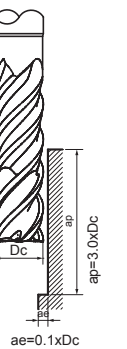
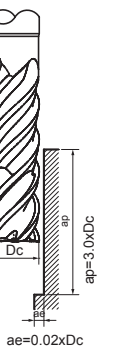
F524SX F525SX		F524SX		F524SX		F524SX		F524SX		F525SX		F525SX	
								cutting speed Vc (m/min)	feed per tooth fz(mm)	cutting speed Vc (m/min)	feed per tooth fz(mm)	cutting speed Vc (m/min)	feed per tooth fz(mm)
Carbon Steel Materials													
P	GR1 Carbon Steel	120	0.006xDc	120	0.006xDc	130	0.006xDc	140	0.007xDc	110	0.006xDc	120	0.006xDc
	GR2 <24HRC Low-alloyed Steel	120	0.005xDc	120	0.005xDc	130	0.005xDc	140	0.006xDc	110	0.005xDc	120	0.005xDc
	GR3 <30HRC Hi-alloyed Steel	80	0.005xDc	80	0.005xDc	90	0.005xDc	100	0.006xDc	70	0.005xDc	80	0.005xDc
Hardened Steel Materials													
H	GR4 30-38HRC Hardened Steel	65	0.004xDc	90	0.003xDc	90	0.003xDc	100	0.003xDc	90	0.004xDc	100	0.003xDc
	GR5 38-48HRC Hardened Steel	60	0.003xDc	80	0.003xDc	80	0.003xDc	90	0.003xDc	70	0.003xDc	80	0.003xDc
Stainless Steel Materials													
M	GR8-1 Ferritic \ Martensitic	80	0.003xDc	90	0.004xDc	110	0.003xDc	130	0.003xDc	70	0.003xDc	80	0.004xDc
	GR8-2 Austenitic	70	0.003xDc	80	0.003xDc	90	0.003xDc	100	0.003xDc	60	0.003xDc	70	0.003xDc
	GR8-3 Austenitic-ferritic	40	0.002xDc	50	0.003xDc	90	0.002xDc	60	0.002xDc	50	0.002xDc	60	0.003xDc
	GR8-4 Austenitic-ferritic Heat-resistant	30	0.002xDc	40	0.003xDc	40	0.002xDc	50	0.002xDc	40	0.002xDc	50	0.003xDc
Cast Iron Materials													
K	GR9-1 Grey cast iron	110	0.006xDc	110	0.006xDc	120	0.006xDc	130	0.007xDc	100	0.006xDc	110	0.005xDc
	GR9-2 Nodular cast iron	120	0.006xDc	120	0.006xDc	130	0.006xDc	140	0.007xDc	110	0.006xDc	120	0.005xDc

All cutting data serve for orientation only and should be adapted individually to the technical conditions on location

1. Please work with good rigidity / high precision facilities and collet chuck.
2. Please choose proper cutting fluid.
3. The cutting data is reference value only. Please adjust it according to your real working conditions.
4. If RPM is lower the reference value, the Feed rate (fz) and RPM should be reduced by the same proportion.
5. If vibration occurs during cutting, please reduce cutting parameter.

F517TX / F518TX / F636TX

Multipurpose End Mills

Designed with two variable helix geometry, two unequal flutes.
 Designed with high removal cutting geometry.
 The use of Si-silicon AlTiSiN coating has excellent wear resistance.

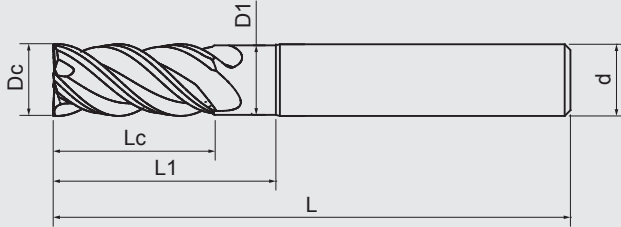

VHM Carbide **AlTiSiN TX** **N** 75° 0.05-0.2 45° **Steel <56HRC**

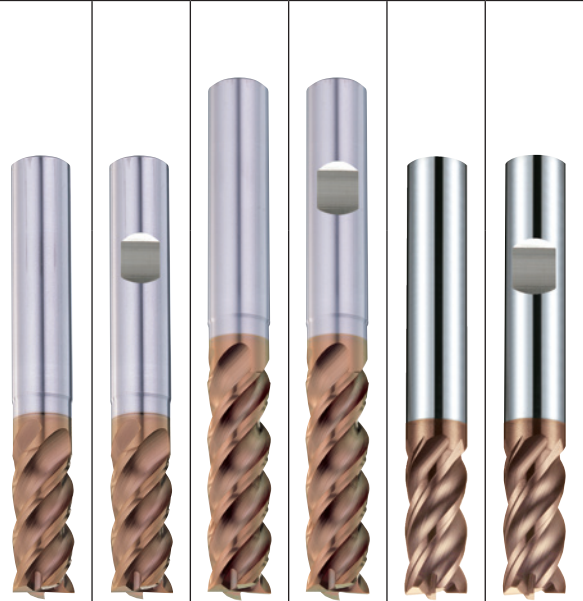

Improved cutting edge strength for cutting different materials below 56HRC, stainless steel, cast iron as well as aluminium.
 Application from roughing to finishing cutting, drilling, ramping... in different materials.

P	P	P	P	P	P
H	H	H	H	H	H
M	M	M	M	M	M
K	K	K	K	K	K

DIN 6527 Standard Length

Dc 0 -0.02	Lc mm	L mm	d h5	L1 mm	D1 mm	45° mm	F517TX HA	F517TX HB			F636TX HA	F636TX HB
3	8	57	6	14	2.8	0.10	●	●			●	●
4	11	57	6	16	3.8	0.10	●	●			●	●
5	13	57	6	18	4.8	0.15	●	●			●	●
6	13	57	6	20	5.8	0.15	●	●			●	●
8	19	63	8	26	7.7	0.15	●	●			●	●
10	22	72	10	31	9.7	0.20	●	●			●	●
12	26	83	12	37	11.6	0.20	●	●			●	●
14	26	83	14	37	13.5	0.20	●	●				
16	32	92	16	43	15.5	0.20	●	●			●	●
18	32	92	18	43	17.5	0.20	●	●				
20	38	104	20	53	19.5	0.20	●	●			●	●

Long Length

Dc 0 -0.02	Lc mm	L mm	d h5	L1 mm	D1 mm	45° mm			F518TX HA	F518TX HB		
6	19	63	6	26	5.8	0.15			●	●		
8	28	72	8	35	7.7	0.15			●	●		
10	34	84	10	43	9.7	0.20			●	●		
12	40	97	12	51	11.6	0.20			●	●		
16	48	108	16	59	15.5	0.20			●	●		
20	56	122	20	71	19.5	0.20			●	●		

Cutting Conditions

F517TX F518TX F636TX		F517TX		F517TX		F517TX		F517TX		F518TX		F518TX		F636TX		F636TX	
		cutting speed Vc (m/min)	feed per tooth fz (mm)	cutting speed Vc (m/min)	feed per tooth fz (mm)	cutting speed Vc (m/min)	feed per tooth fz (mm)	cutting speed Vc (m/min)	feed per tooth fz (mm)	cutting speed Vc (m/min)	feed per tooth fz (mm)	cutting speed Vc (m/min)	feed per tooth fz (mm)	cutting speed Vc (m/min)	feed per tooth fz (mm)	cutting speed Vc (m/min)	feed per tooth fz (mm)
Carbon Steel Materials																	
P	GR1 Carbon Steel	120	0.006xDc	120	0.006xDc	130	0.006xDc	140	0.007xDc	110	0.006xDc	120	0.006xDc	120	0.006xDc	120	0.006xDc
	GR2 <24HRC Low-alloyed Steel	100	0.005xDc	100	0.005xDc	110	0.005xDc	120	0.006xDc	110	0.005xDc	100	0.005xDc	100	0.005xDc	120	0.005xDc
	GR3 <30HRC Hi-alloyed Steel	80	0.005xDc	80	0.005xDc	90	0.005xDc	100	0.006xDc	70	0.005xDc	80	0.005xDc	80	0.005xDc	80	0.005xDc
Hardened Steel Materials																	
H	GR4 30-38HRC Hardened Steel	65	0.004xDc	90	0.003xDc	90	0.003xDc	100	0.003xDc	90	0.004xDc	100	0.003xDc	100	0.004xDc	90	0.003xDc
	GR5 38-48HRC Hardened Steel	60	0.003xDc	80	0.003xDc	80	0.003xDc	90	0.003xDc	70	0.003xDc	90	0.003xDc	80	0.003xDc	80	0.003xDc
Stainless Steel Materials																	
M	GR8-1 Ferritic \ Martensitic	60	0.002xDc	70	0.004xDc	110	0.003xDc	130	0.003xDc	70	0.003xDc	80	0.004xDc	60	0.002xDc	70	0.004xDc
	GR8-2 Austenitic	50	0.002xDc	60	0.003xDc	90	0.003xDc	100	0.003xDc	60	0.003xDc	70	0.003xDc	50	0.002xDc	60	0.003xDc
	GR8-3 Austenitic-ferritic	40	0.002xDc	50	0.003xDc	90	0.002xDc	60	0.002xDc	50	0.002xDc	60	0.003xDc	40	0.002xDc	50	0.003xDc
	GR8-4 Austenitic-ferritic Heat-resistant	30	0.002xDc	40	0.003xDc	40	0.002xDc	50	0.002xDc	40	0.002xDc	50	0.003xDc	30	0.002xDc	40	0.003xDc
Cast Iron Materials																	
K	GR9-1 Grey cast iron	110	0.006xDc	110	0.006xDc	120	0.006xDc	130	0.007xDc	100	0.006xDc	130	0.005xDc	110	0.006xDc	110	0.006xDc
	GR9-2 Nodular cast iron	120	0.006xDc	120	0.006xDc	130	0.006xDc	140	0.007xDc	110	0.006xDc	140	0.005xDc	120	0.006xDc	120	0.006xDc

All cutting data serve for orientation only and should be adapted individually to the technical conditions on location

1. Please work with good rigidity / high precision facilities and collet chuck.
2. Please choose proper cutting fluid.
3. The cutting data is reference value only. Please adjust it according to your real working conditions.
4. If RPM is lower the reference value, the Feed rate (fz) and RPM should be reduced by the same proportion.
5. If vibration occurs during cutting, please reduce cutting parameter.

F608HX / F609HX

Roughing End Mills

Fine tooth staggered chip breaker design on cutting flutes are good for chip breaking.
Good wear resistance and lubricating effect with Nano multilayer coating.

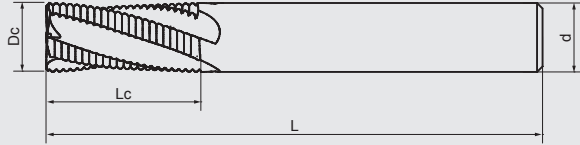
VHM
CarbideAlTiCrN
HXSteel
<48HRC

Suitable for cutting different steel below 48HRC as well as cast iron.

Application for roughing cutting process.



DIN 6527 Standard Length

Dc h10	Lc mm	L mm	d h5	Z T	45° mm	F608HX HA	F608HX HB				
3	8	57	6	3	0.3	●	●				
4	11	57	6	3	0.3	●	●				
5	13	57	6	3	0.4	●	●				
6	13	57	6	3	0.4	●	●				
8	19	63	8	3	0.4	●	●				
10	22	72	10	4	0.5	●	●				
12	26	83	12	4	0.5	●	●				
14	26	83	14	4	0.5	●	●				
16	32	92	16	4	0.5	●	●				
18	32	92	18	4	0.5	●	●				
20	38	104	20	4	0.5	●	●				

Long Length

Dc h10	Lc mm	L mm	d h5	Z T	45° mm			F609HX HA	F609HX HB		
6	19	63	6	3	0.4			●	●		
8	28	72	8	3	0.4			●	●		
10	34	84	10	4	0.5			●	●		
12	40	97	12	4	0.5			●	●		
16	48	108	16	4	0.5			●	●		
20	56	122	20	4	0.5			●	●		

Cutting Conditions

F608HX F609HX							
		cutting speed Vc (m/min)	feed per tooth fz(mm)	cutting speed Vc (m/min)	feed per tooth fz(mm)	cutting speed Vc (m/min)	feed per tooth fz(mm)
Carbon Steel Materials							
P	GR1 Carbon Steel	60	0.006xDc	70	0.006xDc	80	0.006xDc
	GR2 <24HRC Low-alloyed Steel	60	0.005xDc	70	0.005xDc	80	0.005xDc
	GR3 <30HRC Hi-alloyed Steel	50	0.005xDc	60	0.005xDc	70	0.005xDc
Hardened Steel Materials							
H	GR4 30-38HRC Hardened Steel	45	0.003xDc	65	0.003xDc	70	0.003xDc
	GR5 38-48HRC Hardened Steel	40	0.003xDc	60	0.003xDc	65	0.003xDc
Cast Iron Materials							
K	GR9-1 Grey cast iron	60	0.006xDc	70	0.006xDc	80	0.006xDc
	GR9-2 Nodular cast iron	60	0.006xDc	70	0.006xDc	80	0.006xDc

All cutting data serve for orientation only and should be adapted individually to the technical conditions on location

1. Please work with good rigidity / high precision facilities and collet chuck.
2. Please choose proper cutting fluid.
3. The cutting data is reference value only. Please adjust it according to your real working conditions.
4. If RPM is lower the reference value, the Feed rate [fz] and RPM should be reduced by the same proportion.
5. If vibration occurs during cutting, please reduce cutting parameter.

F638TX / F649TX

Roughing End Mills

Fine tooth staggered chip breaker design on cutting flutes are good for chip breaking.
 Good wear resistance and lubricating effect with Nano multilayer coating.

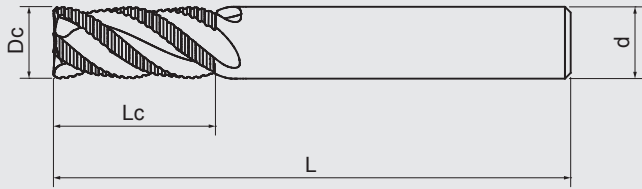

VHM Carbide
 AlTiSiN TX
 40° / 42°
 4
 NEW-HR
 0.3-0.5 45°
 Steel <56HRC

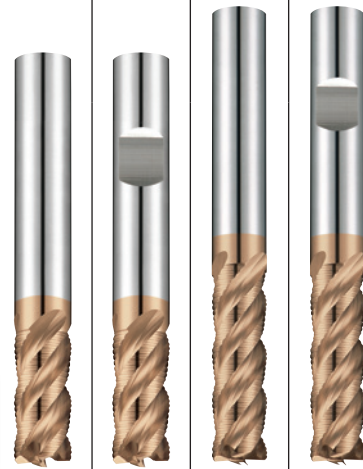

Suitable for cutting different steel below 56HRC as well as cast iron.
 Application for roughing cutting process.

P H M
 P H M
 P H M
 P H M

DIN 6527 Standard Length

Dc h10	Lc mm	L mm	d h5	Z T	45° mm	F638TX HA	F638TX HB				
3	8	57	6	3	0.3	●	●				
4	11	57	6	3	0.3	●	●				
5	13	57	6	3	0.4	●	●				
6	13	57	6	4	0.4	●	●				
8	19	63	8	4	0.4	●	●				
10	22	72	10	4	0.5	●	●				
12	26	83	12	4	0.5	●	●				
14	26	83	14	4	0.5	●	●				
16	32	92	16	4	0.5	●	●				
18	32	92	18	4	0.5	●	●				
20	38	104	20	4	0.5	●	●				

Long Length

Dc h10	Lc mm	L mm	d h5	Z T	45° mm			F649TX HA	F649TX HB		
6	19	63	6	4	0.4			●	●		
8	28	72	8	4	0.4			●	●		
10	34	84	10	4	0.5			●	●		
12	40	97	12	4	0.5			●	●		
16	48	108	16	4	0.5			●	●		
20	56	122	20	4	0.5			●	●		

Cutting Conditions

F638TX F649TX							
		cutting speed Vc (m/min)	feed per tooth fz(mm)	cutting speed Vc (m/min)	feed per tooth fz(mm)	cutting speed Vc (m/min)	feed per tooth fz(mm)
Carbon Steel Materials							
P	GR1 Carbon Steel	60	0.006xDc	70	0.006xDc	80	0.006xDc
	GR2 <24HRC Low-alloyed Steel	60	0.005xDc	70	0.005xDc	80	0.005xDc
	GR3 <30HRC Hi-alloyed Steel	50	0.005xDc	60	0.005xDc	70	0.005xDc
Hardened Steel Materials							
H	GR4 30-38HRC Hardened Steel	45	0.003xDc	65	0.003xDc	70	0.003xDc
	GR5 38-48HRC Hardened Steel	40	0.003xDc	60	0.003xDc	65	0.003xDc
Stainless Steel Materials							
M	GR8-1 Ferritic \ Martensitic	60	0.002xDc	70	0.004xDc	80	0.003xDc
	GR8-2 Austenitic	50	0.002xDc	60	0.003xDc	70	0.003xDc
	GR8-3 Austenitic-ferritic	40	0.002xDc	50	0.003xDc	60	0.002xDc
	GR8-4 Austenitic-ferritic Heat-resistant	30	0.002xDc	40	0.003xDc	50	0.002xDc

All cutting data serve for orientation only and should be adapted individually to the technical conditions on location

1. Please work with good rigidity / high precision facilities and collet chuck.
2. Please choose proper cutting fluid.
3. The cutting data is reference value only. Please adjust it according to your real working conditions.
4. If RPM is lower the reference value, the Feed rate (fz) and RPM should be reduced by the same proportion.
5. If vibration occurs during cutting, please reduce cutting parameter.

F651SX

End Mills For Difficult To Cut Materials

Designed with two variable helix geometry and two unequal flutes.

Sharp cutting edge is good for cutting toughness materials.

Designed with high removal cutting geometry.

Good wear resistance and lubricating effect with Nano multilayer coating.

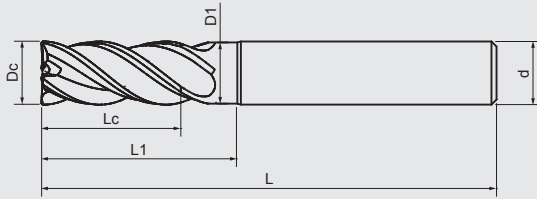

VHM
Carbide

AlTiXN+ZrN
SX



0.05-0.2
Stainless
Titanium
Nickel

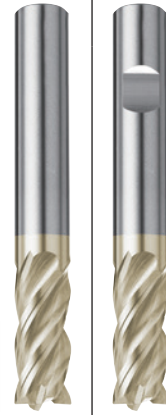

Sharp cutting edge is suitable for cutting stainless steel, titanium, nickel and high temp alloys... etc.
Application for roughing and finishing cutting in different materials.

M
S

M
S

DIN 6527 Standard Length

Dc 0 -0.02	Lc mm	L mm	d h5	L1 mm	D1 mm	45° mm	F651SX HA	F651SX HB				
3	8	57	6	14	2.8	0.10	●	●				
4	11	57	6	16	3.8	0.10	●	●				
5	13	57	6	18	4.8	0.15	●	●				
6	13	57	6	20	5.8	0.15	●	●				
8	19	63	8	26	7.7	0.15	●	●				
10	22	72	10	31	9.7	0.20	●	●				
12	26	83	12	37	11.6	0.20	●	●				
16	32	92	16	43	15.5	0.20	●	●				
20	38	104	20	53	19.5	0.20	●	●				

Cutting Conditions

F651SX									
	cutting speed Vc (m/min)	feed per tooth fz (mm)	cutting speed Vc (m/min)	feed per tooth fz (mm)	cutting speed Vc (m/min)	feed per tooth fz (mm)	cutting speed Vc (m/min)	feed per tooth fz (mm)	
Stainless Steel Materials									
M	GR8-1 Ferritic \ Martensitic	80	0.003xDc	90	0.004xDc	110	0.003xDc	130	0.003xDc
	GR8-2 Austenitic	70	0.003xDc	80	0.003xDc	90	0.003xDc	100	0.003xDc
	GR8-3 Austenitic-ferritic	40	0.002xDc	50	0.003xDc	60	0.002xDc	70	0.002xDc
	GR8-4 Austenitic-ferritic Heat-resistant	30	0.002xDc	40	0.003xDc	40	0.002xDc	50	0.002xDc
Cast Iron Materials									
	GRI5 Titanium	35	0.002xDc	40	0.002xDc	40	0.002xDc	45	0.002xDc
Nickel Materials									
S	GRI6-1 Nickel	30	0.002xDc	35	0.002xDc	35	0.002xDc	40	0.002xDc
	GRI6-2 cobalt-base alloys	30	0.002xDc	35	0.002xDc	35	0.002xDc	40	0.002xDc
	GRI6-3 Iron-based alloy	30	0.002xDc	35	0.002xDc	35	0.002xDc	40	0.002xDc
Heat-resistant Steel Materials									
	GRI7 Heat-resistant Steel	30	0.002xDc	35	0.002xDc	35	0.002xDc	40	0.002xDc

All cutting data serve for orientation only and should be adapted individually to the technical conditions on location

1. Please work with good rigidity / high precision facilities and collet chuck.
2. Please choose proper cutting fluid.
3. The cutting data is reference value only. Please adjust it according to your real working conditions.
4. If RPM is lower the reference value, the Feed rate (fz) and RPM should be reduced by the same proportion.
5. If vibration occurs during cutting, please reduce cutting parameter.

F652SX

End Mills With Corner Radius For Difficult To Cut Materials

Designed with two variable helix geometry and two unequal flutes.

Sharp cutting edge is good for cutting toughness materials.

Designed with high removal cutting geometry.

Improved cutting edge strength with corner radius.

Applicable for profile surface machining.

Good wear resistance and lubricating effect with Nano multilayer coating.

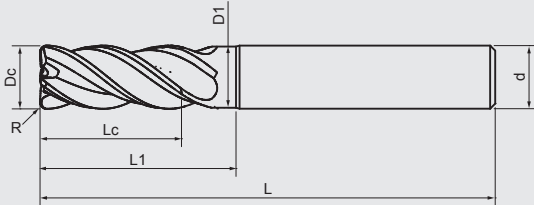

VHM
Carbide

AlTiXN+ZrN
SX



Stainless
Titanium
Nickel

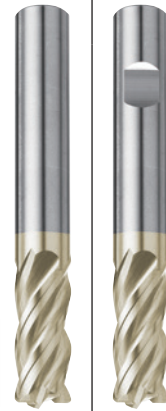

Sharp cutting edge is suitable for cutting stainless steel, titanium, nickel and high temp alloys... etc.

Application for roughing and finishing cutting in different materials.

M
S

M
S

DIN 6527 Standard Length

Dc 0 -0.02	R ±0.01	Lc mm	L mm	d h5	L1 mm	D1 mm	F652SX HA	F652SX HB				
3	R0.2	8	57	6	14	2.8	●	●				
4	R0.2	11	57	6	16	3.8	●	●				
5	R0.2	13	57	6	18	4.8	●	●				
6	R0.2	13	57	6	20	5.8	●	●				
8	R0.2	19	63	8	26	7.7	●	●				
10	R0.2	22	72	10	31	9.7	●	●				
12	R0.2	26	83	12	37	11.6	●	●				
16	R0.2	32	92	16	43	15.5	●	●				
20	R0.2	38	104	20	53	19.5	●	●				
3	R0.5	8	57	6	14	2.8	●	●				
4	R0.5	11	57	6	16	3.8	●	●				
5	R0.5	13	57	6	18	4.8	●	●				
6	R0.5	13	57	6	20	5.8	●	●				
8	R0.5	19	63	8	26	7.7	●	●				
10	R0.5	22	72	10	31	9.7	●	●				
12	R0.5	26	83	12	37	11.6	●	●				
16	R0.5	32	92	16	43	15.5	●	●				
20	R0.5	38	104	20	53	19.5	●	●				
6	R1	13	57	6	20	5.8	●	●				
8	R1	19	63	8	26	7.7	●	●				
10	R1	22	72	10	31	9.7	●	●				
12	R1	26	83	12	37	11.6	●	●				
16	R1	32	92	16	43	15.5	●	●				
20	R1	38	104	20	53	19.5	●	●				
6	R2	13	57	6	20	5.8	●	●				
8	R2	19	63	8	26	7.7	●	●				
10	R2	22	72	10	31	9.7	●	●				
12	R2	26	83	12	37	11.6	●	●				
16	R2	32	92	16	43	15.5	●	●				
20	R2	38	104	20	53	19.5	●	●				
12	R3	26	83	12	37	11.6	●	●				
16	R3	32	92	16	43	15.5	●	●				
20	R3	38	104	20	53	19.5	●	●				

Cutting Conditions

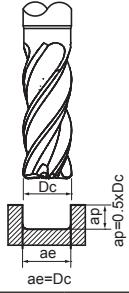
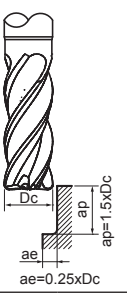
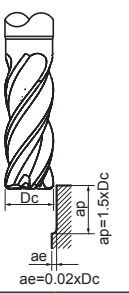
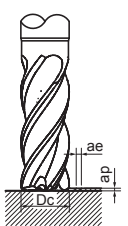
F652SX									
	cutting speed Vc (m/min)	feed per tooth fz (mm)	cutting speed Vc (m/min)	feed per tooth fz (mm)	cutting speed Vc (m/min)	feed per tooth fz (mm)	cutting speed Vc (m/min)	feed per tooth fz (mm)	
Stainless Steel Materials									
M	GR8-1 Ferritic \ Martensitic	80	0.003xDc	90	0.004xDc	110	0.003xDc	130	0.003xDc
	GR8-2 Austenitic	70	0.003xDc	80	0.003xDc	90	0.003xDc	100	0.003xDc
	GR8-3 Austenitic-ferritic	40	0.002xDc	50	0.003xDc	60	0.002xDc	70	0.002xDc
	GR8-4 Austenitic-ferritic Heat-resistant	30	0.002xDc	40	0.003xDc	40	0.002xDc	50	0.002xDc
Cast Iron Materials									
	GR15 Titanium	35	0.002xDc	40	0.002xDc	40	0.002xDc	45	0.002xDc
Nickel Materials									
S	GR16-1 Nickel	30	0.002xDc	35	0.002xDc	35	0.002xDc	40	0.002xDc
	GR16-2 cobalt-base alloys	30	0.002xDc	35	0.002xDc	35	0.002xDc	40	0.002xDc
	GR16-3 Iron-based alloy	30	0.002xDc	35	0.002xDc	35	0.002xDc	40	0.002xDc
Heat-resistant Steel Materials									
	GR17 Heat-resistant Steel	30	0.002xDc	35	0.002xDc	35	0.002xDc	40	0.002xDc

All cutting data serve for orientation only and should be adapted individually to the technical conditions on location

1. Please work with good rigidity / high precision facilities and collet chuck.
2. Please choose proper cutting fluid.
3. The cutting data is reference value only. Please adjust it according to your real working conditions.
4. If RPM is lower the reference value, the Feed rate (fz) and RPM should be reduced by the same proportion.
5. If vibration occurs during cutting, please reduce cutting parameter.

F653SX

End Mills With Corner Radius For Difficult To Cut Materials

Designed with two variable helix geometry and two unequal flutes.

Sharp cutting edge is good for cutting toughness materials.

Designed with high removal cutting geometry.

Improved cutting edge strength with corner radius.

Good wear resistance and lubricating effect with Nano multilayer coating.

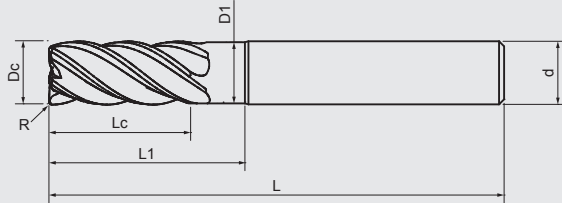

VHM
Carbide

AlTiXN+ZrN
SX



Stainless
Titanium
Nickel

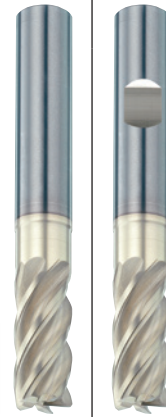

Sharp cutting edge is suitable for cutting stainless steel, titanium, nickel and high temp alloys... etc.
Application for HPC/ roughing cutting and HSC/ finishing cutting.

M
S

M
S

DIN 6527 Standard Length

Dc 0 -0.02	R ±0.01	Lc mm	L mm	d h5	L1 mm	D1 mm	F653SX HA	F653SX HB				
3	R0.5	8	57	6	14	2.8	●	●				
4	R0.5	11	57	6	16	3.8	●	●				
5	R0.5	13	57	6	18	4.8	●	●				
6	R0.5	13	57	6	20	5.8	●	●				
8	R0.5	19	63	8	26	7.7	●	●				
10	R0.5	22	72	10	31	9.7	●	●				
12	R0.5	26	83	12	37	11.6	●	●				
16	R0.5	32	92	16	43	15.5	●	●				
20	R0.5	38	104	20	53	19.5	●	●				

Cutting Conditions

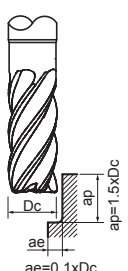
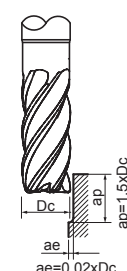
F653SX									
		cutting speed Vc (m/min)	feed per tooth fz(mm)	cutting speed Vc (m/min)	feed per tooth fz(mm)	cutting speed Vc (m/min)	feed per tooth fz(mm)	cutting speed Vc (m/min)	feed per tooth fz(mm)
Stainless Steel Materials									
M	GR8-1 Ferritic \ Martensitic	80		0.003xDc		90		0.004xDc	
	GR8-2 Austenitic	70		0.003xDc		80		0.003xDc	
	GR8-3 Austenitic-ferritic	40		0.002xDc		50		0.003xDc	
	GR8-4 Austenitic-ferritic Heat-resistant	30		0.002xDc		40		0.003xDc	
Cast Iron Materials									
	GRI5 Titanium	35		0.002xDc		40		0.002xDc	
Nickel Materials									
S	GRI6-1 Nickel	30		0.002xDc		35		0.002xDc	
	GRI6-2 cobalt-base alloys	30		0.002xDc		35		0.002xDc	
	GRI6-3 Iron-based alloy	30		0.002xDc		35		0.002xDc	
Heat-resistant Steel Materials									
	GRI7 Heat-resistant Steel	30		0.002xDc		35		0.002xDc	

All cutting data serve for orientation only and should be adapted individually to the technical conditions on location

1. Please work with good rigidity / high precision facilities and collet chuck.
2. Please choose proper cutting fluid.
3. The cutting data is reference value only. Please adjust it according to your real working conditions.
4. If RPM is lower the reference value, the Feed rate (fz) and RPM should be reduced by the same proportion.
5. If vibration occurs during cutting, please reduce cutting parameter.

F631ZX / F631 / F632

End Mills For Aluminium

Designed with three variable helix geometry and three unequal flutes.

Designed with sharp cutting edge, high removal cutting geometry, and fine grinding smooth surface to prevent sticking problem.

Adopting ZrN coating without AlTi in the formula would prevent from chemical affinity with Alu metal and enhance tool life by gaining better surface hardness.

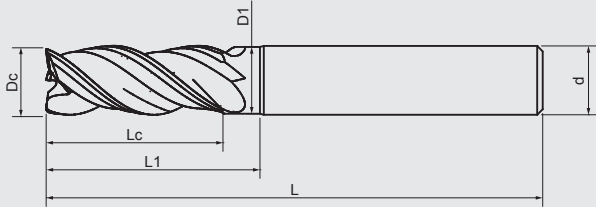

VHM Carbide

Bright ZrN



90°

Aluminium



Suitable for cutting aluminium.

Application for HPC/ roughing cutting process with high chip removal rate as well as for HSC/ finishing cutting with fine and smooth surface finishing.

N

N

N

DIN 6527 Standard Length

Dc 0 -0.02	Lc mm	L mm	d h5	L1 mm	D1 mm	F631ZX ZrN	F631 Bright				
3	8	57	6	14	2.8	●	●				
4	11	57	6	16	3.8	●	●				
5	13	57	6	18	4.8	●	●				
6	13	57	6	20	5.8	●	●				
8	19	63	8	26	7.7	●	●				
10	22	72	10	31	9.7	●	●				
12	26	83	12	37	11.6	●	●				
16	32	92	16	43	15.5	●	●				
20	38	104	20	53	19.5	●	●				

Long Length

Dc 0 -0.02	Lc mm	L mm	d h5	L1 mm	D1 mm			F632 Bright			
6	19	63	6	26	5.8			●			
8	28	72	8	35	7.7			●			
10	34	84	10	43	9.7			●			
12	40	97	12	51	11.6			●			
16	48	108	16	59	15.5			●			
20	56	122	20	71	19.5			●			

Cutting Conditions

F631ZX F631 F632									
	cutting speed Vc (m/min)	feed per tooth fz (mm)	cutting speed Vc (m/min)	feed per tooth fz (mm)	cutting speed Vc (m/min)	feed per tooth fz (mm)	cutting speed Vc (m/min)	feed per tooth fz (mm)	
Aluminium Steel Materials									
N	GRI0-1 Wrought Aluminium alloys	400	0.005xDc	400	0.006xDc	400	0.007xDc	400	0.008xDc
	GRI0-2 Aluminium cast alloys <10%	400	0.005xDc	400	0.006xDc	400	0.007xDc	400	0.008xDc
	GRI0-3 Aluminium cast alloys >10%	350	0.005xDc	380	0.006xDc	380	0.007xDc	380	0.008xDc

All cutting data serve for orientation only and should be adapted individually to the technical conditions on location

1. Please work with good rigidity / high precision facilities and collet chuck.
2. Please choose proper cutting fluid.
3. The cutting data is reference value only. Please adjust it according to your real working conditions.
4. If RPM is lower the reference value, the Feed rate (fz) and RPM should be reduced by the same proportion.
5. If vibration occurs during cutting, please reduce cutting parameter.

F607ZX

Toric End Mills For Aluminium

Designed with three variable helix geometry and three unequal flutes.

Designed with sharp cutting edge, high removal cutting geometry, and fine grinding smooth surface to prevent sticking problem.

Cutting edge with corner radius for profile machining.

Adopting ZrN coating without AlTi in the formula would prevent from chemical affinity with Alu metal and enhance tool life by gaining better surface hardness.

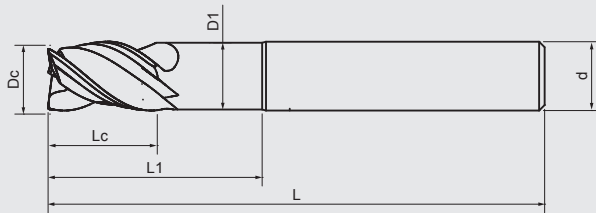

VHM
Carbide

ZrN
ZX



90°

Aluminium



Suitable for cutting aluminium.

Application for HPC/ roughing cutting process with high chip removal rate as well as for HSC/ finishing cutting process with fine and smooth surface finishing.

N

DIN 6527 Standard Length

Dc 0 -0.02	Lc mm	L mm	d h5	L1 mm	D1 mm	F607ZX ZrN					
3	4.5	57	6	9	2.8	●					
4	6	57	6	12	3.7	●					
5	7.5	57	6	15	4.6	●					
6	9	57	6	20	5.5	●					
8	12	63	8	26	7.4	●					
10	15	72	10	31	9.2	●					
12	18	83	12	37	11	●					
16	24	92	16	43	14.5	●					
20	30	104	20	53	18.2	●					

Cutting Conditions

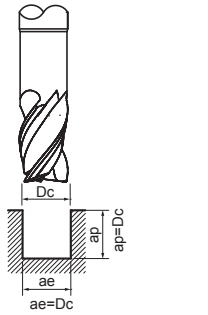
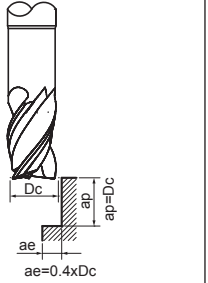
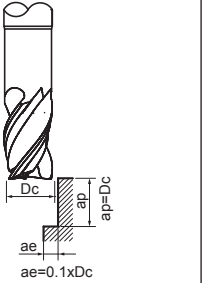
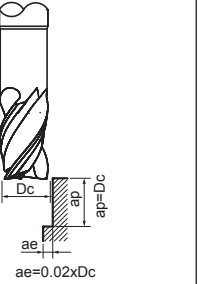
F607ZX									
		cutting speed Vc (m/min)	feed per tooth fz (mm)	cutting speed Vc (m/min)	feed per tooth fz (mm)	cutting speed Vc (m/min)	feed per tooth fz (mm)	cutting speed Vc (m/min)	feed per tooth fz (mm)
Aluminium Steel Materials									
N	GRI0-1 Wrought Aluminium alloys	400	0.005xDc	400	0.006xDc	400	0.007xDc	400	0.008xDc
	GRI0-2 Aluminium cast alloys <10%	400	0.005xDc	400	0.006xDc	400	0.007xDc	400	0.008xDc
	GRI0-3 Aluminium cast alloys >10%	350	0.005xDc	380	0.006xDc	380	0.007xDc	380	0.008xDc

All cutting data serve for orientation only and should be adapted individually to the technical conditions on location

1. Please work with good rigidity / high precision facilities and collet chuck.
2. Please choose proper cutting fluid.
3. The cutting data is reference value only. Please adjust it according to your real working conditions.
4. If RPM is lower the reference value, the Feed rate (fz) and RPM should be reduced by the same proportion.
5. If vibration occurs during cutting, please reduce cutting parameter.

F642ZX / F643ZX

Roughing End Mills For Aluminium

Coarse tooth staggered chip breaker design on cutting flutes are good for easily chip breaking.
Adopting ZrN coating without AlTi in the formula would prevent from chemical affinity with Alu metal and enhance tool life by gaining better surface hardness.

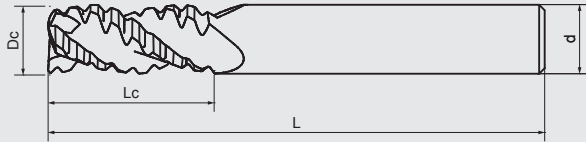
VHM
CarbideZrN
ZX

40°



3



γ15°



0.3-0.5

45°

Aluminium



Suitable for cutting aluminium.
Application for roughing cutting with high chip removal rate.

N

N

DIN 6527 Standard Length

Dc 0 -0.02	Lc mm	L mm	d h5	F642ZX ZrN					
3	8	57	6	●					
4	11	57	6	●					
5	13	57	6	●					
6	13	57	6	●					
8	19	63	8	●					
10	22	72	10	●					
12	26	83	12	●					
16	32	92	16	●					
20	38	104	20	●					

Long Length

Dc 0 -0.02	Lc mm	L mm	d h5		F643ZX ZrN				
6	19	63	6		●				
8	28	72	8		●				
10	34	84	10		●				
12	40	97	12		●				
16	48	108	16		●				
20	56	122	20		●				

Cutting Conditions

F642ZX F643ZX					
	cutting speed Vc (m/min)	feed per tooth fz(mm)	cutting speed Vc (m/min)	feed per tooth fz(mm)	
Aluminium Steel Materials					
N	GRI0-1 Wrought Aluminium alloys	400	0.008xDc	400	0.009xDc
	GRI0-2 Aluminium cast alloys <10%	400	0.008xDc	400	0.009xDc
	GRI0-3 Aluminium cast alloys >10%	350	0.008xDc	380	0.009xDc

All cutting data serve for orientation only and should be adapted individually to the technical conditions on location

1. Please work with good rigidity / high precision facilities and collet chuck.
2. Please choose proper cutting fluid.
3. The cutting data is reference value only. Please adjust it according to your real working conditions.
4. If RPM is lower the reference value, the Feed rate (fz) and RPM should be reduced by the same proportion.
5. If vibration occurs during cutting, please reduce cutting parameter.

F618ZX / F620ZX

Ball Nose End Mills For Aluminium

40° helix with round cutting edge and mirror sharp grinding on side cutting edge.

Various applications on Aluminium for curved profile milling.

Adopting ZrN coating without AlTi in the formula would prevent from chemical affinity with Alu metal and enhance tool life by decreasing friction and gaining better surface hardness and smoothness.

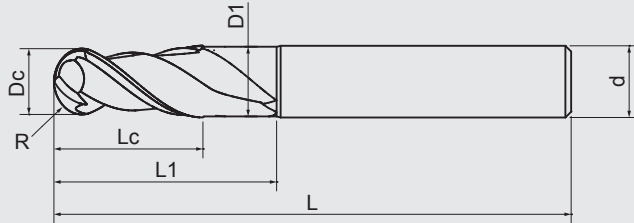

VHM
Carbide

ZrN
ZX



Aluminium



Suitable for cutting aluminium.

Application for roughing cutting with high chip removal rate.

N

N

DIN 6527 Standard Length

Dc 0 -0.02	R ±0.005	Lc mm	L mm	Lc mm	L1 mm	D1 h5	F618ZX ZrN					
3	1.5R	6	57	6	9	2.8	●					
4	2R	8	57	6	12	3.7	●					
5	2.5R	10	57	6	15	4.6	●					
6	3R	12	57	6	20	5.5	●					
8	4R	16	63	8	26	7.4	●					
10	5R	20	72	10	31	9.2	●					
12	6R	24	83	12	37	11.0	●					

Long Length

Dc 0 -0.02	R ±0.005	Lc mm	L mm	Lc mm	L1 mm	D1 h5		F620ZX ZrN				
3	1.5R	6	70	6	9	2.8		●				
4	2R	8	70	6	12	3.7		●				
5	2.5R	10	80	6	15	4.6		●				
6	3R	12	80	6	20	5.5		●				
8	4R	16	100	8	26	7.4		●				
10	5R	20	100	10	31	9.2		●				
12	6R	24	110	12	37	11.0		●				

Cutting Conditions

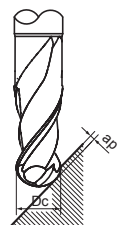



F618ZX F620ZX								
	cutting speed Vc (m/min)	feed per tooth fz (mm)	ae	ap	cutting speed Vc (m/min)	feed per tooth fz (mm)	ap	
Aluminium Steel Materials								
N	GRI0-1 Wrought Aluminium alloys	800	0.021xDc	0.2xDc	0.05xDc	900	0.016xDc	0.02xDc
	GRI0-2 Aluminium cast alloys <10%	800	0.021xDc	0.2xDc	0.05xDc	900	0.014xDc	0.02xDc
	GRI0-3 Aluminium cast alloys >10%	700	0.020xDc	0.2xDc	0.05xDc	800	0.012xDc	0.02xDc

All cutting data serve for orientation only and should be adapted individually to the technical conditions on location

1. Please work with good rigidity / high precision facilities and collet chuck.
2. Please choose proper cutting fluid.
3. The cutting data is reference value only. Please adjust it according to your real working conditions.
4. If RPM is lower the reference value, the Feed rate (fz) and RPM should be reduced by the same proportion.
5. If vibration occurs during cutting, please reduce cutting parameter.



Thread Mills

Page	245	247	249			
Apperance						
Code No	T740TX	T781HX	T783			
Carbide	VHM Carbide	VHM Carbide	VHM Carbide			
Coating	AlTiSiN TX	AlTiCrN HX	Uncoated Bright			
Helix Angle	 15°	 11°	 30°			
No.of Flutes	 3~4Z	 3~5Z	 3~5Z			

DIN

T740TX

Oil-Feed Thread Mills Drills

ISO Metric Standard Thread

Design with left-handed and right-cutting edge is beneficial for cutting and getting better chip removal rate.

Cutter tip with chamfering function.

Internal oil-feed design to provide with better cooling effect and chip removal.

Good wear resistance effect with Nano multilayer coating.

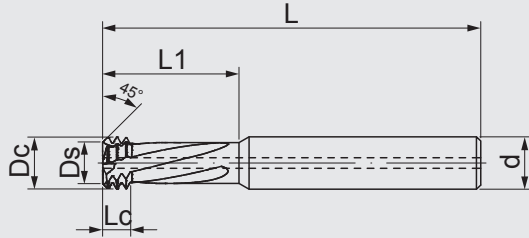

VHM
Carbide

AlTiSiN
TX



Steel
<52HRC



Milling with Thread holes with plunging Helix directly.

Suitable for carbon steel, below 52HRC hardened steel, stainless steel, cast iron...etc.



Standard Length

Thread		Pitch	Dc	Lc	L1	L	d	Ds	t	T740TX					
Coarse	Fine	mm	mm	mm	mm	mm	h6	mm	mm	AlTiSiN					
M3×0.5	M4×0.5	0.5	2.4	1.5	7	57	6	2.1	3	●					
		0.7	3.2	2.1	9.2	57	6	2.9	3	●					
		0.8	3.9	2.4	11.5	57	6	3.5	3	●					
M6~M7×1	M8~M9×1	1	4.7	3	14	57	6	4.2	3	●					
		1.25	6.1	3.75	18	63	8	5.6	4	●					
M10×1.5	M11~M15×1.5	1.5	7.8	4.5	23	63	8	7.2	4	●					
		1.75	9	5.25	26	72	10	8.4	4	●					
M16×2	M17~M23×2	2	11.8	6	35	83	12	11.2	4	●					

Cutting Conditions

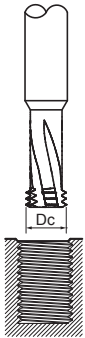
T740TX			
	cutting speed Vc (m/min)	feed per tooth fz(mm)	
Carbon Steel Materials			
P	GR1 Carbon Steel	60	0.016xDc
	GR2 <24HRC Low-alloyed Steel	60	0.016xDc
	GR3 <30HRC Hi-alloyed Steel	60	0.016xDc
Hardened Steel Materials			
H	GR4 30-38HRC Hardened Steel	30	0.01xDc
	GR5 38-48HRC Hardened Steel	20	0.01xDc
Stainless Steel Materials			
M	GR8-1 Ferritic \ Martensitic	30	0.01xDc
	GR8-2 Austenitic	30	0.01xDc
	GR8-3 Austenitic-ferritic	20	0.01xDc
	GR8-4 Austenitic-ferritic Heat-resistant	15	0.01xDc
Cast Iron Materials			
K	GR9-1 Grey cast iron	60	0.016xDc
	GR9-2 Nodular cast iron	60	0.016xDc

All cutting data serve for orientation only and should be adapted individually to the technical conditions on location

1. Please work with good rigidity / high precision facilities and collet chuck.
2. Please choose proper cutting fluid.
3. The cutting data is reference value only. Please adjust it according to your real working conditions.
4. If RPM is lower the reference value, the Feed rate (fz) and RPM should be reduced by the same proportion.
5. If vibration occurs during cutting, please reduce cutting parameter.

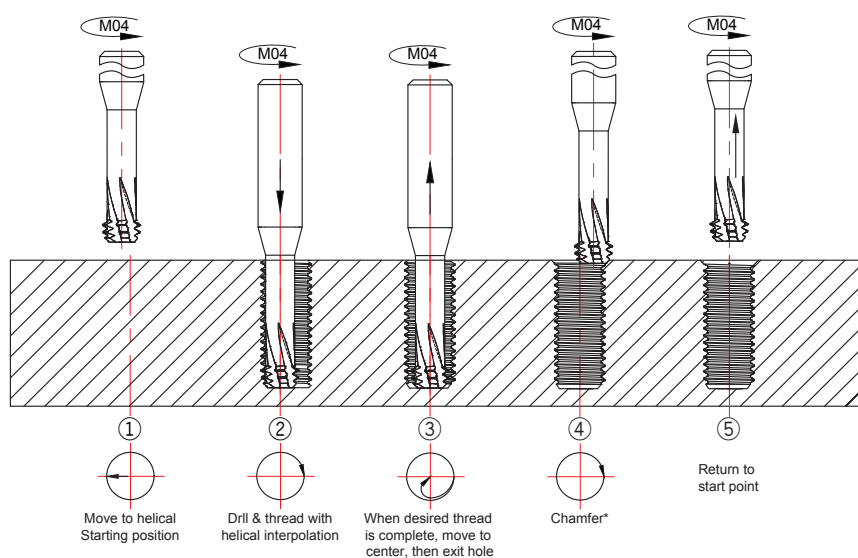

T781HX

Micro Thread Mills / Oil-Feed Thread Mills

ISO Metric Standard Thread
 Good wear resistance effect with Nano multilayer coating.

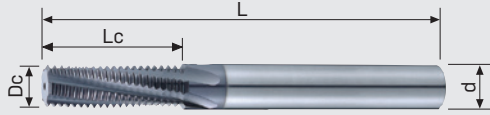

VHM Carbide
AlTiCrN HX
11°
3-5Z
78°
Steel <48HRC

Dc	Dc	Dc	Dc	P	P
				H	H
				M	M
				K	K

Suitable for carbon steel, below 48HRC hardened steel, stainless steel, cast iron...etc.



Standard Length

Thread	Pitch	Dc	Lc	L1	L	d	t	Zt	T781HX	T781HX				
									AlTiCrN	AlTiCrN				
Coarse	Fine	mm	mm	mm	mm	h6	mm							
M1×0.25		0.25	0.72	0.25	2.8	50	4	3	1	●				
M1.2×0.25		0.25	0.91	0.25	3.3	50	4	3	1	●				
M1.4×0.3		0.3	1.05	0.3	3.8	50	4	3	1	●				
M1.6×0.35		0.35	1.2	0.35	4.3	50	4	3	1	●				
M1.8×0.35		0.35	1.3	0.35	4.8	50	4	3	1	●				
M2×0.4		0.4	1.5	1.2	4.5	50	4	3	3		●			
M2.5×0.45		0.45	1.9	1.4	5.6	50	4	3	3		●			
M3×0.5	M3.5~M16×0.5	0.5	2.4	1.5	6.5	50	4	3	3		●			
M4×0.7		0.7	3.1	2.1	8.7	50	6	3	3		●			
M5×0.8		0.8	4	2.4	10.8	50	6	3	3		●			

Standard Length

Thread	Pitch	Dc	Lc	L1	L	d	t	T781HX	T781HX				
								AlTiCrN	AlTiCrN				
Coarse	Fine	mm	mm	mm	mm	h6	mm						
M6×1		1	4.5	13	15	60	6	4		●			
M8×1.25		1.25	6	17.8	—	65	6	4		●			
M10×1.5		1.5	7.5	22.5	25	70	8	4		●			
M12×1.75		1.75	9.5	26.3	27	80	10	5			●		
M14×2		2	10	30	—	90	10	5			●		
M16×2		2	12	34	—	100	12	5			●		
M20×2.5		2.5	16	42.5	—	110	16	5			●		

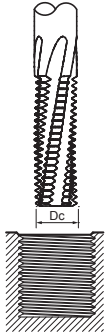
Cutting Conditions

T781HX					
		cutting speed Vc (m/min)	feed per tooth fz(mm)	cutting speed Vc (m/min)	feed per tooth fz(mm)
Carbon Steel Materials					
P	GR1 Carbon Steel	120	0.016xDc	40	0.006xDc
	GR2 <24HRC Low-alloyed Steel	100	0.016xDc	30	0.005xDc
	GR3 <30HRC Hi-alloyed Steel	80	0.016xDc	20	0.005xDc
Hardened Steel Materials					
H	GR4 30-38HRC Hardened Steel	90	0.01xDc	10	0.003xDc
	GR5 38-48HRC Hardened Steel	80	0.01xDc	10	0.003xDc
Stainless Steel Materials					
M	GR8-1 Ferritic \ Martensitic	70	0.01xDc	20	0.004xDc
	GR8-2 Austenitic	60	0.01xDc	20	0.003xDc
	GR8-3 Austenitic-ferritic	50	0.01xDc	20	0.003xDc
	GR8-4 Austenitic-ferritic Heat-resistant	40	0.01xDc	20	0.003xDc
Cast Iron Materials					
K	GR9-1 Grey cast iron	110	0.016xDc	40	0.006xDc
	GR9-2 Nodular cast iron	120	0.016xDc	30	0.006xDc

All cutting data serve for orientation only and should be adapted individually to the technical conditions on location

1. Please work with good rigidity / high precision facilities and collet chuck.
2. Please choose proper cutting fluid.
3. The cutting data is reference value only. Please adjust it according to your real working conditions.
4. If RPM is lower the reference value, the Feed rate (fz) and RPM should be reduced by the same proportion.
5. If vibration occurs during cutting, please reduce cutting parameter.

Micro Thread Mills / Oil-Feed Thread Mills

ISO Metric Standard Thread.

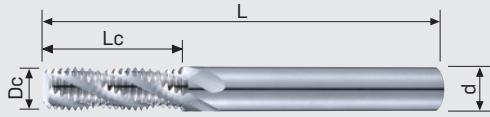

VHM Carbide
Uncoated Bright
30°
3-5Z
78°
Aluminium

Dc	Dc	Dc	Dc	N	N

Suitable for cutting in different Aluminium materials.



Standard Length

Thread		Pitch	Dc	Lc	L1	L	d	t	Zt	T783 Bright	T783 Bright				
Coarse	Fine	mm	mm	mm	mm	mm	h6	mm							
M1×0.25		0.25	0.72	0.25	2.8	50	4	3	1	●					
M1.2×0.25		0.25	0.91	0.25	3.3	50	4	3	1	●					
M1.4×0.3		0.3	1.05	0.3	3.8	50	4	3	1	●					
M1.6×0.35		0.35	1.2	0.35	4.3	50	4	3	1	●					
M1.8×0.35		0.35	1.3	0.35	4.8	50	4	3	1	●					
M2×0.4		0.4	1.5	1.2	4.5	50	4	3	3		●				
M2.5×0.45		0.45	1.9	1.4	5.6	50	4	3	3		●				
M3×0.5	M3.5~M16×0.5	0.5	2.4	1.5	6.5	50	4	3	3		●				
M4×0.7		0.7	3.1	2.1	8.7	50	6	3	3		●				
M5×0.8		0.8	4	2.4	10.8	50	6	3	3		●				

Standard Length

Thread		Pitch	Dc	Lc	L1	L	d	t			T783 Bright	T783 Bright			
Coarse	Fine	mm	mm	mm	mm	mm	h6	mm							
M6×1		1	4.5	13	15	60	6	4			●				
M8×1.25		1.25	6	17.8	—	65	6	4			●				
M10×1.5		1.5	7.5	22.5	25	70	8	4			●				
M12×1.75		1.75	9.5	26.3	27	80	10	5				●			
M14×2		2	10	30	—	90	10	5				●			
M16×2		2	12	34	—	100	12	5				●			
M20×2.5		2.5	16	42.5	—	110	16	5				●			

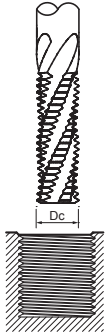

















Cutting Conditions

T783					
	cutting speed Vc (m/min)	feed per tooth fz(mm)	cutting speed Vc (m/min)	feed per tooth fz(mm)	
Aluminium Steel Materials					
N	GR10-1 Wrought Aluminium alloys	200	0.016xDc	60	0.01xDc
	GR10-2 Aluminium cast alloys <10%	150	0.014xDc	50	0.008xDc
	GR10-3 Aluminium cast alloys >10%	150	0.012xDc	40	0.005xDc































All cutting data serve for orientation only and should be adapted individually to the technical conditions on location

1. Please work with good rigidity / high precision facilities and collet chuck.
2. Please choose proper cutting fluid.
3. The cutting data is reference value only. Please adjust it according to your real working conditions.
4. If RPM is lower the reference value, the Feed rate (fz) and RPM should be reduced by the same proportion.
5. If vibration occurs during cutting, please reduce cutting parameter.

End Mills

Page	253	253	255	255	257	257
Apperance						
Code No	E102HX	E104HX	F500HX F501HX	F602TX	F503HX F504HX	F603TX
Carbide	VHM Carbide	VHM Carbide	VHM Carbide	VHM Carbide	VHM Carbide	VHM Carbide
Coating	AlTiCrN HX	AlTiCrN HX	AlTiCrN HX	AlTiSiN TX	AlTiCrN HX	AlTiSiN TX
Helix Angle	 30°	 30°	 30°	 35°	 30°	 35°
No.of Flutes	 2	 4	 2	 2	 3	 3

DIN

259	261	263	265	267	269	271	273	275	277
									
F506HX F507HX	F604TX F606TX	F660TX F661TX	B202HX	F520HX F521HX	F623HX F624HX	F625TX F626TX	F615TX F619TX	F613TX F614TX	F676TX
VHM Carbide	VHM Carbide	VHM Carbide	VHM Carbide	VHM Carbide	VHM Carbide	VHM Carbide	VHM Carbide	VHM Carbide	VHM Carbide
AlTiCrN HX	AlTiSiN TX	AlTiSiN TX	AlTiCrN HX	AlTiCrN HX	AlTiCrN HX	AlTiSiN TX	AlTiSiN TX	AlTiSiN TX	AlTiSiN TX
 30°	 35°	 55°	 30°	 30°	 30°	 30°	 30°	 45°	 0°
 4	 4	 Z	 2	 2	 2	 2	 4	 6	 4

E102HX / E104HX

Universal End Mills / Finishing End Mills

Small diameter series with specification in step of 0.1mm.
 Good wear resistance and lubricating effect with Nano multilayer coating.

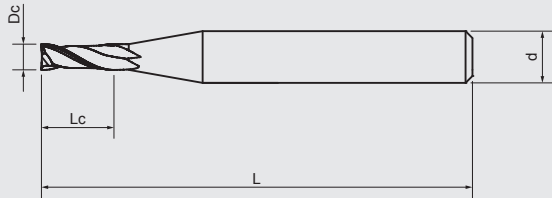

VHM Carbide
AlTiCrN HX
30°
N
90°
Steel <48HRC

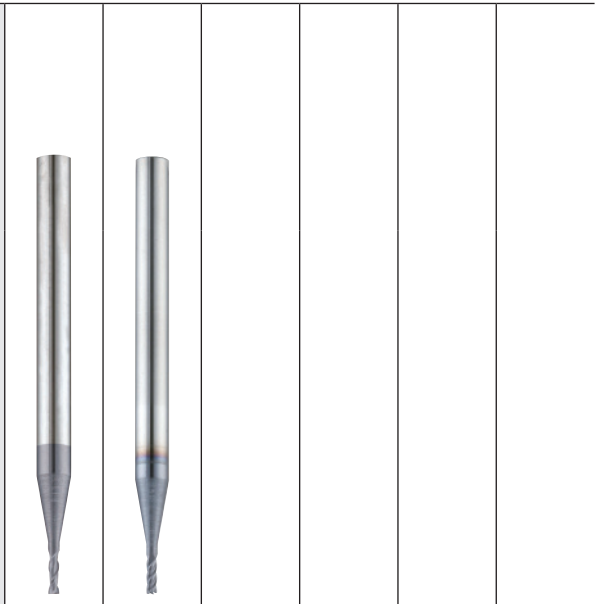

Suitable for cutting different steels below 48HRC as well as cast iron.
 Various application for general cutting.

P
P
H
H
K
K

Standard Length

Dc 0 -0.02	Lc mm	L mm	d h5	E102HX AlTiCrN	E104HX AlTiCrN				
0.2	0.5	38	3	●					
0.3	0.8	38	3	●					
0.4	1	38	3	●					
0.5	1.2	38	3	●					
0.6	1.5	38	3	●					
0.7	1.8	38	3	●					
0.8	2	38	3	●					
0.9	2.5	38	3	●					
1	3	38	3	●	●				
1.1	3	38	3	●	●				
1.2	4	38	3	●	●				
1.3	4	38	3	●	●				
1.4	4	38	3	●	●				
1.5	5	38	3	●	●				
1.6	5	38	3	●	●				
1.7	5	38	3	●	●				
1.8	5	38	3	●	●				
1.9	5	38	3	●	●				
2	6	38	3	●	●				
2.1	6	38	3	●	●				
2.2	6	38	3	●	●				
2.3	6	38	3	●	●				
2.4	8	38	3	●	●				
2.5	8	38	3	●	●				
2.6	8	38	3	●	●				
2.7	8	38	3	●	●				
2.8	8	38	3	●	●				
2.9	8	38	3	●	●				
3	8	38	3	●	●				

Cutting Conditions

	E102HX		E102HX		E104HX		E104HX		
	cutting speed Vc (m/min)	feed per tooth fz (mm)	cutting speed Vc (m/min)	feed per tooth fz (mm)	cutting speed Vc (m/min)	feed per tooth fz (mm)	cutting speed Vc (m/min)	feed per tooth fz (mm)	
P	Carbon Steel Materials								
	GR1 Carbon Steel	120	0.0015xDc	120	0.0018xDc	120	0.0015xDc	120	0.0018xDc
	GR2 <24HRC Low-alloyed Steel	120	0.0015xDc	120	0.0018xDc	120	0.0015xDc	120	0.0018xDc
	GR3 <30HRC Hi-alloyed Steel	80	0.0012xDc	80	0.0015xDc	80	0.0012xDc	80	0.0015xDc
H	Hardened Steel Materials								
	GR4 30-38HRC Hardened Steel	60	0.001xDc	65	0.001xDc	60	0.001xDc	65	0.001xDc
	GR5 38-48HRC Hardened Steel	55	0.001xDc	60	0.001xDc	55	0.001xDc	60	0.001xDc
K	Cast Iron Materials								
	GR9-1 Grey cast iron	120	0.0015xDc	120	0.0018xDc	120	0.0015xDc	120	0.0018xDc
	GR9-2 Nodular cast iron	120	0.0015xDc	120	0.0018xDc	120	0.0015xDc	120	0.0018xDc

1. Please work with good rigidity / high precision facilities and collet chuck.
2. Please choose proper cutting fluid.
3. The cutting data is reference value only. Please adjust it according to your real working conditions.
4. If RPM is lower the reference value, the Feed rate (fz) and RPM should be reduced by the same proportion.
5. If vibration occurs during cutting, please reduce cutting parameter.

F500HX / F501HX / F602TX

Universal End Mills

F500HX / F501HX With MG carbide material is good for cutting materials < 48HRC.
 F602TX With UMG carbide material is good for cutting hardened materials < 62HRC.
 Good wear resistance and lubricating effect with Nano multilayer coating.

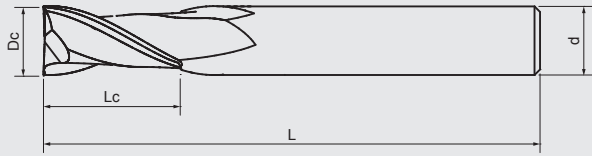

VHM Carbide
 AlTiCrN HX
 AlTiSiN TX
 30°
 2
 N
 0.05-0.2
 45°

P H K	P H K	P H K	P H K	P H	P H
AlTiCrN <48HRC	AlTiCrN <48HRC	AlTiCrN <48HRC	AlTiCrN <48HRC	AlTiSiN <62HRC	AlTiSiN <62HRC

F500HX / F501HX With sharp cutting edge is good for cutting different steels below 48HRC as well as cast iron.
 F602TX With stronger Strength of cutting edge is suitable for steels below 62HRC.
 Various application for general cutting.

DIN 6527 Stub Length

Dc 0 -0.02	Lc mm	L mm	d h5	45° mm	F500HX HA	F500HX HB				
2	3	50	6	0.02	●	●				
3	4	50	6	0.03	●	●				
4	5	54	6	0.04	●	●				
5	6	54	6	0.05	●	●				
6	7	54	6	0.06	●	●				
8	9	58	8	0.08	●	●				
10	11	66	10	0.10	●	●				
12	12	73	12	0.12	●	●				
14	14	75	14	0.14	●	●				
16	16	82	16	0.16	●	●				
18	18	84	18	0.18	●	●				
20	20	92	20	0.20	●	●				

DIN 6527 Standard Length

Dc 0 -0.02	Lc mm	L mm	d h5	45° mm			F501HX HA	F501HX HB		
3	7	57	6	0.03			●	●		
4	8	57	6	0.04			●	●		
5	10	57	6	0.05			●	●		
6	10	57	6	0.06			●	●		
8	16	63	8	0.08			●	●		
10	19	72	10	0.10			●	●		
12	22	83	12	0.12			●	●		
14	22	83	14	0.14			●	●		
16	26	92	16	0.16			●	●		
18	26	92	18	0.18			●	●		
20	32	104	20	0.20			●	●		

DIN 6527 Standard Length

Dc 0 -0.02	Lc mm	L mm	d h5	45° mm					F602TX HA	F602TX HB
3	7	57	6	0.03					●	●
4	8	57	6	0.04					●	●
5	10	57	6	0.05					●	●
6	10	57	6	0.06					●	●
8	16	63	8	0.08					●	●
10	19	72	10	0.10					●	●
12	22	83	12	0.12					●	●
16	26	92	16	0.16					●	●
20	32	104	20	0.20					●	●

Cutting Conditions

F500HX F501HX F602TX		F500HX		F500HX		F501HX		F501HX		F602TX		F602TX		F602TX	
		cutting speed Vc (m/min)	feed per tooth fz (mm)	cutting speed Vc (m/min)	feed per tooth fz (mm)	cutting speed Vc (m/min)	feed per tooth fz (mm)	cutting speed Vc (m/min)	feed per tooth fz (mm)	cutting speed Vc (m/min)	feed per tooth fz (mm)	cutting speed Vc (m/min)	feed per tooth fz (mm)	cutting speed Vc (m/min)	feed per tooth fz (mm)
Carbon Steel Materials															
P	GR1 Carbon Steel	120	0.004xDc	120	0.005xDc	130	0.005xDc	140	0.006xDc	120	0.004xDc	120	0.005xDc	130	0.005xDc
	GR2 <24HRC Low-alloyed Steel	120	0.003xDc	120	0.004xDc	130	0.004xDc	140	0.005xDc	120	0.003xDc	120	0.004xDc	130	0.004xDc
	GR3 <30HRC Hi-alloyed Steel	80	0.003xDc	80	0.003xDc	90	0.003xDc	100	0.004xDc	80	0.003xDc	80	0.003xDc	90	0.003xDc
Hardened Steel Materials															
H	GR4 30-38HRC Hardened Steel	65	0.002xDc	65	0.002xDc	65	0.002xDc	70	0.002xDc	65	0.002xDc	65	0.002xDc	65	0.002xDc
	GR5 38-48HRC Hardened Steel	60	0.0018xDc	60	0.0018xDc	60	0.0018xDc	65	0.0018xDc	60	0.0018xDc	60	0.0018xDc	60	0.0018xDc
	GR6 48-56HRC Hardened Steel									55	0.0015xDc	55	0.0015xDc	55	0.0015xDc
Cast Iron Materials															
K	GR9-1 Grey cast iron	120	0.004xDc	120	0.005xDc	130	0.005xDc	140	0.006xDc						
	GR9-2 Nodular cast iron	120	0.004xDc	120	0.005xDc	130	0.005xDc	140	0.006xDc						

All cutting data serve for orientation only and should be adapted individually to the technical conditions on location

1. Please work with good rigidity / high precision facilities and collet chuck.
2. Please choose proper cutting fluid.
3. The cutting data is reference value only. Please adjust it according to your real working conditions.
4. If RPM is lower the reference value, the Feed rate (fz) and RPM should be reduced by the same proportion.
5. If vibration occurs during cutting, please reduce cutting parameter.

F503HX / F504HX / F603TX

Universal End Mills

F503HX / F504HX With MG carbide material is good for cutting materials < 48HRC.

F603TX With UMG carbide material is good for cutting hardened materials < 62HRC.

Good wear resistance and lubricating effect with Nano multilayer coating.

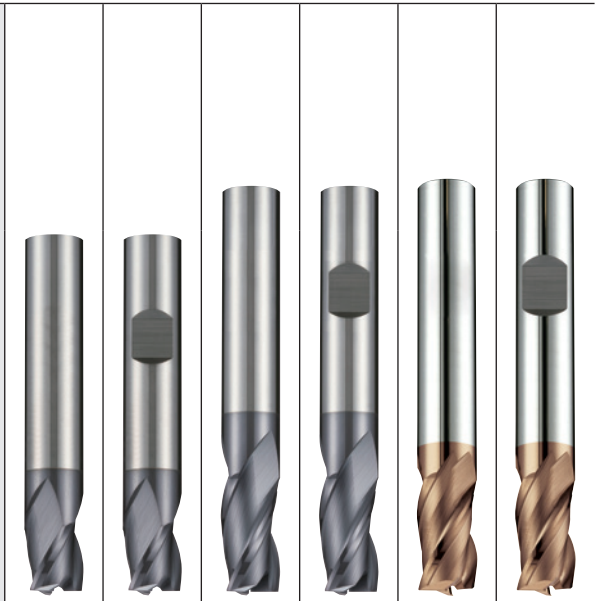
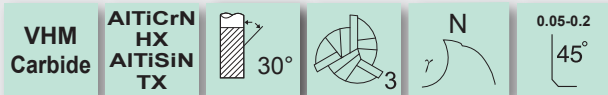
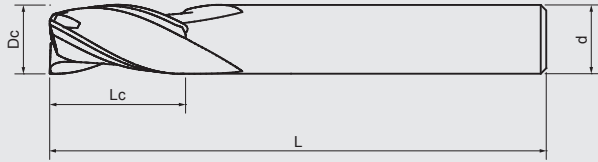

F503HX / F504HX With sharp cutting edge is good for cutting different steels below 48HRC as well as cast iron.

F603TX With stronger strength of cutting edge is suitable for steels below 62HRC.

Various application for general cutting.

P H K	P H K	P H K	P H K	P H	P H
AlTiCrN <48HRC	AlTiCrN <48HRC	AlTiCrN <48HRC	AlTiCrN <48HRC	AlTiSiN <62HRC	AlTiSiN <62HRC

DIN 6527 Stub Length

Dc 0 -0.02	Lc mm	L mm	d h5	45° mm	F503HX HA	F503HX HB				
2	3	50	6	0.02	●	●				
3	4	50	6	0.03	●	●				
4	5	54	6	0.04	●	●				
5	6	54	6	0.05	●	●				
6	7	54	6	0.06	●	●				
8	9	58	8	0.08	●	●				
10	11	66	10	0.10	●	●				
12	12	73	12	0.12	●	●				
14	14	75	14	0.14	●	●				
16	16	82	16	0.16	●	●				
18	18	84	18	0.18	●	●				
20	20	92	20	0.20	●	●				

DIN 6527 Standard Length

Dc 0 -0.02	Lc mm	L mm	d h5	45° mm			F504HX HA	F504HX HB		
3	7	57	6	0.03			●	●		
4	8	57	6	0.04			●	●		
5	10	57	6	0.05			●	●		
6	10	57	6	0.06			●	●		
8	16	63	8	0.08			●	●		
10	19	72	10	0.10			●	●		
12	22	83	12	0.12			●	●		
14	22	83	14	0.14			●	●		
16	26	92	16	0.16			●	●		
18	26	92	18	0.18			●	●		
20	32	104	20	0.20			●	●		

DIN 6527 Standard Length

Dc 0 -0.02	Lc mm	L mm	d h5	45° mm				F603TX HA	F603TX HB
3	7	57	6	0.03				●	●
4	8	57	6	0.04				●	●
5	10	57	6	0.05				●	●
6	10	57	6	0.06				●	●
8	16	63	8	0.08				●	●
10	19	72	10	0.10				●	●
12	22	83	12	0.12				●	●
16	26	92	16	0.16				●	●
20	32	104	20	0.20				●	●

Cutting Conditions

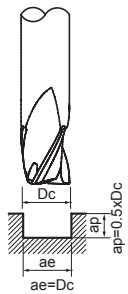
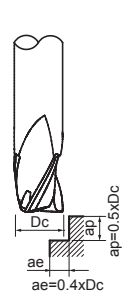
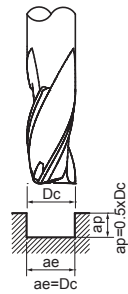
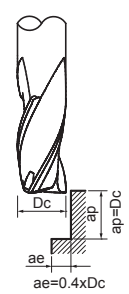
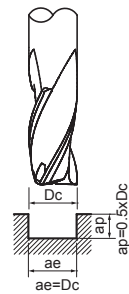
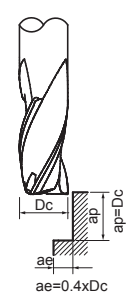
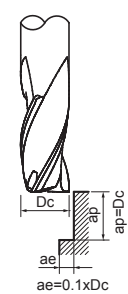
F503HX F504HX F603TX		F503HX		F503HX		F504HX		F504HX		F603TX		F603TX		F603TX	
															
		cutting speed Vc (m/min)	feed per tooth fz (mm)	cutting speed Vc (m/min)	feed per tooth fz (mm)	cutting speed Vc (m/min)	feed per tooth fz (mm)	cutting speed Vc (m/min)	feed per tooth fz (mm)	cutting speed Vc (m/min)	feed per tooth fz (mm)	cutting speed Vc (m/min)	feed per tooth fz (mm)	cutting speed Vc (m/min)	feed per tooth fz (mm)
Carbon Steel Materials															
P	GR1 Carbon Steel	120	0.004xDc	120	0.005xDc	130	0.005xDc	140	0.006xDc	120	0.004xDc	120	0.005xDc	130	0.005xDc
	GR2 <24HRC Low-alloyed Steel	120	0.003xDc	120	0.004xDc	130	0.004xDc	140	0.005xDc	120	0.003xDc	120	0.004xDc	130	0.004xDc
	GR3 <30HRC Hi-alloyed Steel	80	0.003xDc	80	0.003xDc	90	0.003xDc	100	0.004xDc	80	0.003xDc	80	0.003xDc	90	0.003xDc
Hardened Steel Materials															
H	GR4 30-38HRC Hardened Steel	65	0.002xDc	65	0.002xDc	65	0.002xDc	70	0.002xDc	65	0.002xDc	65	0.002xDc	65	0.002xDc
	GR5 38-48HRC Hardened Steel	60	0.0018xDc	60	0.0018xDc	60	0.0018xDc	65	0.0018xDc	60	0.0018xDc	60	0.0018xDc	60	0.0018xDc
	GR6 48-56HRC Hardened Steel									55	0.0015xDc	55	0.0015xDc	55	0.0015xDc
Cast Iron Materials															
K	GR9-1 Grey cast iron	120	0.004xDc	120	0.005xDc	130	0.005xDc	140	0.006xDc						
	GR9-2 Nodular cast iron	120	0.004xDc	120	0.005xDc	130	0.005xDc	140	0.006xDc						

All cutting data serve for orientation only and should be adapted individually to the technical conditions on location

1. Please work with good rigidity / high precision facilities and collet chuck.
2. Please choose proper cutting fluid.
3. The cutting data is reference value only. Please adjust it according to your real working conditions.
4. If RPM is lower the reference value, the Feed rate (fz) and RPM should be reduced by the same proportion.
5. If vibration occurs during cutting, please reduce cutting parameter.

F506HX / F507HX

Finishing End Mills

With MG carbide material is good for cutting materials < 48HRC.
Good wear resistance and lubricating effect with Nano multilayer coating.

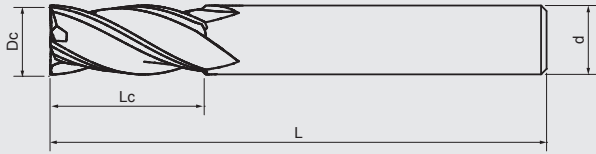

VHM Carbide **AlTiCrN HX** 30° $\gamma 10^\circ$ $0.05-0.2$ 45° **Steel <48HRC**

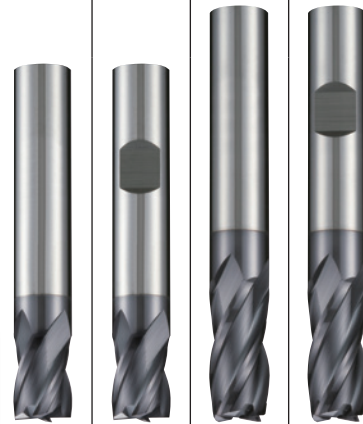

With sharp cutting edge is good for cutting different steels below 48HRC as well as cast iron.
Various application for finishing cutting.



DIN 6527 Stub Length

Dc 0 -0.02	Lc mm	L mm	d h5	45° mm	F506HX HA	F506HX HB				
2	4	50	6	0.02	●	●				
3	5	50	6	0.03	●	●				
4	8	54	6	0.04	●	●				
5	9	54	6	0.05	●	●				
6	10	54	6	0.06	●	●				
8	12	58	8	0.08	●	●				
10	14	66	10	0.10	●	●				
12	16	73	12	0.12	●	●				
14	18	75	14	0.14	●	●				
16	22	82	16	0.16	●	●				
18	24	84	18	0.18	●	●				
20	26	92	20	0.20	●	●				

DIN 6527 Standard Length

Dc 0 -0.02	Lc mm	L mm	d h5	45° mm			F507HX HA	F507HX HB		
3	8	57	6	0.03			●	●		
4	11	57	6	0.04			●	●		
5	13	57	6	0.05			●	●		
6	13	57	6	0.06			●	●		
8	19	63	8	0.08			●	●		
10	22	72	10	0.10			●	●		
12	26	83	12	0.12			●	●		
14	26	83	14	0.14			●	●		
16	32	92	16	0.16			●	●		
18	32	92	18	0.18			●	●		
20	38	104	20	0.20			●	●		

Cutting Conditions

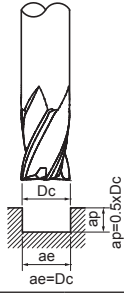
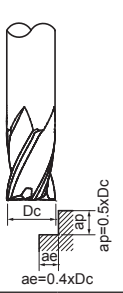
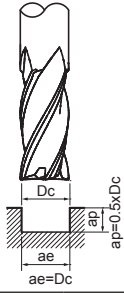
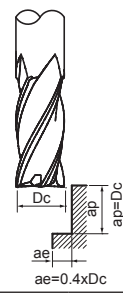
	F506HX		F506HX		F507HX		F507HX		
					cutting speed Vc (m/min)	feed per tooth fz (mm)	cutting speed Vc (m/min)	feed per tooth fz (mm)	
Carbon Steel Materials									
P	GR1 Carbon Steel	120	0.004xDc	120	0.005xDc	130	0.005xDc	140	0.006xDc
	GR2 <24HRC Low-alloyed Steel	120	0.003xDc	120	0.004xDc	130	0.004xDc	140	0.005xDc
	GR3 <30HRC Hi-alloyed Steel	80	0.003xDc	80	0.003xDc	90	0.003xDc	100	0.004xDc
Hardened Steel Materials									
H	GR4 30-38HRC Hardened Steel	65	0.002xDc	65	0.002xDc	65	0.002xDc	70	0.002xDc
	GR5 38-48HRC Hardened Steel	60	0.0018xDc	60	0.0018xDc	60	0.0018xDc	65	0.0018xDc
Cast Iron Materials									
K	GR9-1 Grey cast iron	120	0.004xDc	120	0.005xDc	130	0.005xDc	140	0.006xDc
	GR9-2 Nodular cast iron	120	0.004xDc	120	0.005xDc	130	0.005xDc	140	0.006xDc

All cutting data serve for orientation only and should be adapted individually to the technical conditions on location

1. Please work with good rigidity / high precision facilities and collet chuck.
2. Please choose proper cutting fluid.
3. The cutting data is reference value only. Please adjust it according to your real working conditions.
4. If RPM is lower the reference value, the Feed rate [fz] and RPM should be reduced by the same proportion.
5. If vibration occurs during cutting, please reduce cutting parameter.

F604TX / F606TX

Finishing End Mills

With UMG carbide material is good for cutting hardened materials < 62HRC.
Good wear resistance and lubricating effect with Nano multilayer coating.

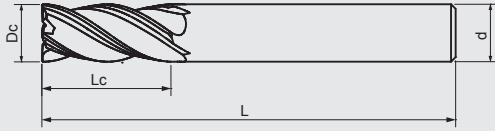

VHM Carbide **AlTiSiN TX** 35° $\gamma 75^\circ$ $0.05-0.2$ 45° **Steel <62HRC**

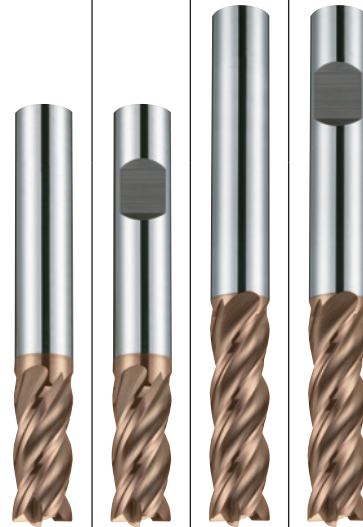

With stronger strength of cutting edge is suitable for steels below 62HRC.
Various application for finishing cutting

P
H **P**
H **P**
H **P**
H

DIN 6527 Standard Length

Dc 0 -0.02	Lc mm	L mm	d h5	45° mm	F604TX HA	F604TX HB				
3	8	57	6	0.03	●	●				
4	11	57	6	0.04	●	●				
5	13	57	6	0.05	●	●				
6	13	57	6	0.06	●	●				
8	19	63	8	0.08	●	●				
10	22	72	10	0.10	●	●				
12	26	83	12	0.12	●	●				
16	32	92	16	0.16	●	●				
20	38	104	20	0.20	●	●				

Long Length

Dc 0 -0.02	Lc mm	L mm	d h5	45° mm			F606TX HA	F606TX HB		
3	12	63	6	0.03			●	●		
4	17	63	6	0.04			●	●		
5	19	63	6	0.05			●	●		
6	19	63	6	0.06			●	●		
8	28	72	8	0.08			●	●		
10	34	84	10	0.10			●	●		
12	40	97	12	0.12			●	●		
16	48	108	16	0.16			●	●		
20	56	122	20	0.20			●	●		

Cutting Conditions

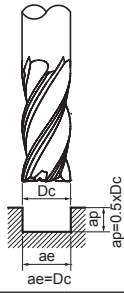
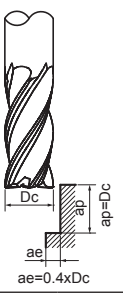
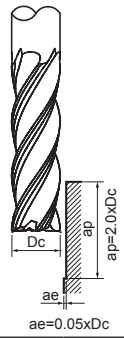
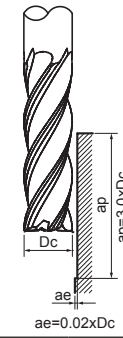
	F504TX		F504TX		F506TX		F506TX		
	cutting speed Vc (m/min)	feed per tooth fz (mm)	cutting speed Vc (m/min)	feed per tooth fz (mm)	cutting speed Vc (m/min)	feed per tooth fz (mm)	cutting speed Vc (m/min)	feed per tooth fz (mm)	
F604TX F606TX									
	Carbon Steel Materials								
	P	GR1 Carbon Steel	120	0.004xDc	120	0.005xDc	130	0.005xDc	140
	GR2 <24HRC Low-alloyed Steel	120	0.003xDc	120	0.004xDc	130	0.004xDc	140	0.003xDc
	GR3 <30HRC Hi-alloyed Steel	80	0.003xDc	80	0.003xDc	90	0.003xDc	100	0.003xDc
Hardened Steel Materials									
H	GR4 30-38HRC Hardened Steel	65	0.002xDc	65	0.002xDc	65	0.002xDc	70	0.002xDc
	GR5 38-48HRC Hardened Steel	60	0.0018xDc	60	0.0018xDc	60	0.0018xDc	65	0.0018xDc
	GR6 48-56HRC Hardened Steel	55	0.0015xDc	55	0.0015xDc	55	0.0015xDc	60	0.0015xDc

All cutting data serve for orientation only and should be adapted individually to the technical conditions on location

1. Please work with good rigidity / high precision facilities and collet chuck.
2. Please choose proper cutting fluid.
3. The cutting data is reference value only. Please adjust it according to your real working conditions.
4. If RPM is lower the reference value, the Feed rate [fz] and RPM should be reduced by the same proportion.
5. If vibration occurs during cutting, please reduce cutting parameter.

F660TX / F661TX

Finishing End Mills

Negative rake angle is good for cutting hardened materials.

Selected Super SMG as tool material.

Good wear resistance and lubricating effect with Nano multilayer coating.

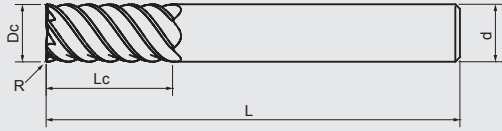

VHM
Carbide

AlTiSiN
TX



Steel
40-70
HRC



Stronger strength of cutting edge is suitable for various materials from 40-70HRC.

Various application for finishing cutting.

H

H

DIN 6527 Standard Length

Dc 0 -0.02	Lc mm	L mm	d h5	Z	R mm	F660TX AlTiSiN					
6	13	57	6	6	0.2	●					
8	19	63	8	6	0.2	●					
10	22	72	10	6	0.2	●					
12	26	83	12	6	0.2	●					
16	32	92	16	8	0.2	●					
20	38	104	20	10	0.2	●					

Long Length

Dc 0 -0.02	Lc mm	L mm	d h5	Z	R mm		F661TX AlTiSiN				
6	19	63	6	6	0.2		●				
8	28	72	8	6	0.2		●				
10	34	84	10	6	0.2		●				
12	40	97	12	6	0.2		●				
16	48	108	16	8	0.2		●				
20	56	122	20	10	0.2		●				

Cutting Conditions

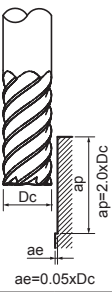
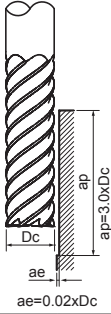
F660TX F661TX	F660TX		F661TX		
					
	cutting speed Vc (m/min)	feed per tooth fz(mm)	cutting speed Vc (m/min)	feed per tooth fz(mm)	
Hardened Steel Materials					
H	GR5 38-48HRC Hardened Steel	150	0.01xDc	130	0.002xDc
	GR6 48-56HRC Hardened Steel	100	0.008xDc	90	0.0018xDc
	GR7 56-68HRC Hardened Steel	90	0.007xDc	80	0.0015xDc

All cutting data serve for orientation only and should be adapted individually to the technical conditions on location

1. Please work with good rigidity / high precision facilities and collet chuck.
2. Please choose proper cutting fluid.
3. The cutting data is reference value only. Please adjust it according to your real working conditions.
4. If RPM is lower the reference value, the Feed rate (fz) and RPM should be reduced by the same proportion.
5. If vibration occurs during cutting, please reduce cutting parameter.

B202HX

Ball Nose End Mills

Designed with S-style ball nose geometry.
Reduce surface cutting resistance.
Good wear resistance and lubricating effect with
Nano multilayer coating.

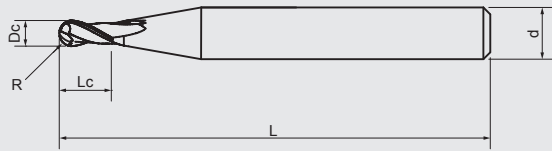

VHM
Carbide

AlTiCrN
HX



Steel
<48HRC



Suitable for cutting different steels below 48HRC
as well as cast iron.
Application for finishing profile cutting.

P
H
K

Standard Length

Dc 0 -0.02	R ±0.01	Lc mm	L mm	d h5	B202HX AlTiCrN					
0.2	0.1R	0.4	38	3	●					
0.3	0.15R	0.6	38	3	●					
0.4	0.2R	0.8	38	3	●					
0.5	0.25R	1	38	3	●					
0.6	0.3R	1.2	38	3	●					
0.7	0.35R	1.4	38	3	●					
0.8	0.4R	1.6	38	3	●					
0.9	0.45R	1.8	38	3	●					
1	0.5R	2	38	3	●					
1.1	0.55R	2.2	38	3	●					
1.2	0.6R	2.4	38	3	●					
1.4	0.7R	2.8	38	3	●					
1.5	0.75R	3	38	3	●					
1.6	0.8R	3.2	38	3	●					
1.8	0.9R	3.6	38	3	●					
2	1R	4	38	3	●					
2.5	1.25R	5	38	3	●					
3	1.5R	6	38	3	●					

Cutting Conditions

B202HX									
		cutting speed Vc (m/min)	feed per tooth fz (mm)	ae	ap	cutting speed Vc (m/min)	feed per tooth fz (mm)	ae	ap
Carbon Steel Materials									
P	GR1 Carbon Steel	120	0.013xDc	0.06xDc	0.06xDc	120	0.013xDc	0.06xDc	0.06xDc
	GR2 <24HRC Low-alloyed Steel	110	0.013xDc	0.06xDc	0.06xDc	110	0.013xDc	0.06xDc	0.06xDc
	GR3 <30HRC Hi-alloyed Steel	100	0.012xDc	0.06xDc	0.06xDc	100	0.012xDc	0.06xDc	0.06xDc
Hardened Steel Materials									
H	GR4 30-38HRC Hardened Steel	60	0.009xDc	0.02xDc	0.02xDc	110	0.01xDc	0.02xDc	0.02xDc
	GR5 38-48HRC Hardened Steel	55	0.008xDc	0.02xDc	0.02xDc	100	0.009xDc	0.02xDc	0.02xDc
Cast Iron Materials									
K	GR9-1 Grey cast iron	120	0.013xDc	0.013xDc	0.013xDc	120	0.013xDc	0.013xDc	0.013xDc
	GR9-2 Nodular cast iron	120	0.013xDc	0.013xDc	0.013xDc	120	0.013xDc	0.013xDc	0.013xDc

All cutting data serve for orientation only and should be adapted individually to the technical conditions on location

1. Please work with good rigidity / high precision facilities and collet chuck.
2. Please choose proper cutting fluid.
3. The cutting data is reference value only. Please adjust it according to your real working conditions.
4. If RPM is lower the reference value, the Feed rate [fz] and RPM should be reduced by the same proportion.
5. If vibration occurs during cutting, please reduce cutting parameter.

F520HX / F521HX

Ball Nose End Mills

Designed with S-style ball nose geometry.
Reduce surface cutting resistance.
Good wear resistance and lubricating effect with
Nano multilayer coating.

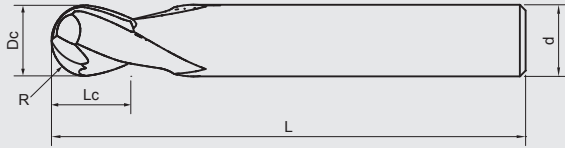

VHM
Carbide

AlTiCrN
HX

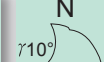

Steel
<48HRC

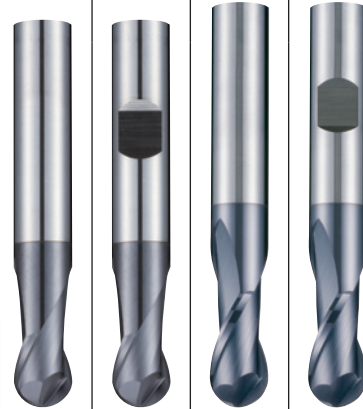

Suitable for cutting different steels below 48HRC
as well as cast iron.
Application for finishing profile cutting.



DIN 6527 Stub Length

Dc 0 -0.02	R ±0.01	Lc mm	L mm	d h5	F520HX HA	F520HX HB				
2	1R	3	50	6	●	●				
3	1.5R	4	50	6	●	●				
4	2R	5	54	6	●	●				
5	2.5R	6	54	6	●	●				
6	3R	7	54	6	●	●				
8	4R	9	58	8	●	●				
10	5R	11	66	10	●	●				
12	6R	12	73	12	●	●				
14	7R	14	75	14	●	●				
16	8R	16	82	16	●	●				
18	9R	18	84	18	●	●				
20	10R	20	92	20	●	●				

DIN 6527 Standard Length

Dc 0 -0.02	R ±0.01	Lc mm	L mm	d h5			F521HX HA	F521HX HB		
3	1.5R	7	57	6			●	●		
4	2R	8	57	6			●	●		
5	2.5R	10	57	6			●	●		
6	3R	10	57	6			●	●		
8	4R	16	63	8			●	●		
10	5R	19	72	10			●	●		
12	6R	22	83	12			●	●		
14	7R	22	83	14			●	●		
16	8R	26	92	16			●	●		
18	9R	26	92	18			●	●		
20	10R	32	104	20			●	●		

Cutting Conditions

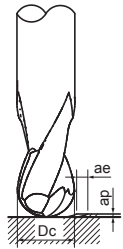
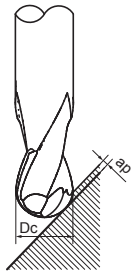
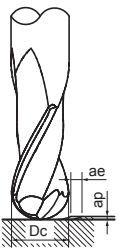
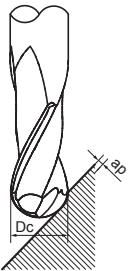
	F520HX				F520HX				F521HX				F521HX				
																	
	cutting speed Vc (m/min)	feed per tooth fz(mm)	ae	ap	cutting speed Vc (m/min)	feed per tooth fz(mm)	ae	ap	cutting speed Vc (m/min)	feed per tooth fz(mm)	ae	ap	cutting speed Vc (m/min)	feed per tooth fz(mm)	ae	ap	
Carbon Steel Materials																	
P	GR1 Carbon Steel	120	0.02xDc	0.2xDc	0.1xDc	120	0.023xDc	0.2xDc	0.1xDc	120	0.02xDc	0.2xDc	0.1xDc	120	0.023xDc	0.2xDc	0.1xDc
	GR2 <24HRC Low-alloyed Steel	110	0.02xDc	0.2xDc	0.1xDc	110	0.022xDc	0.2xDc	0.1xDc	110	0.02xDc	0.2xDc	0.1xDc	110	0.022xDc	0.2xDc	0.1xDc
	GR3 <30HRC Hi-alloyed Steel	100	0.018xDc	0.2xDc	0.1xDc	100	0.021xDc	0.2xDc	0.1xDc	100	0.018xDc	0.2xDc	0.1xDc	100	0.021xDc	0.2xDc	0.1xDc
Hardened Steel Materials																	
H	GR4 30-38HRC Hardened Steel	60	0.015xDc	0.02xDc	0.02xDc	60	0.015xDc	0.02xDc	0.02xDc	60	0.015xDc	0.02xDc	0.02xDc	60	0.015xDc	0.02xDc	0.02xDc
	GR5 38-48HRC Hardened Steel	55	0.012xDc	0.02xDc	0.02xDc	55	0.012xDc	0.02xDc	0.02xDc	55	0.012xDc	0.02xDc	0.02xDc	55	0.012xDc	0.02xDc	0.02xDc
Cast Iron Materials																	
K	GR9-1 Grey cast iron	120	0.02xDc	0.2xDc	0.1xDc	120	0.023xDc	0.2xDc	0.1xDc	120	0.02xDc	0.2xDc	0.1xDc	120	0.023xDc	0.2xDc	0.1xDc
	GR9-2 Nodular cast iron	120	0.02xDc	0.2xDc	0.1xDc	120	0.023xDc	0.2xDc	0.1xDc	120	0.02xDc	0.2xDc	0.1xDc	120	0.023xDc	0.2xDc	0.1xDc

All cutting data serve for orientation only and should be adapted individually to the technical conditions on location

1. Please work with good rigidity / high precision facilities and collet chuck.
2. Please choose proper cutting fluid.
3. The cutting data is reference value only. Please adjust it according to your real working conditions.
4. If RPM is lower the reference value, the Feed rate [fz] and RPM should be reduced by the same proportion.
5. If vibration occurs during cutting, please reduce cutting parameter.

F623HX / F624HX

Ball Nose End Mills

Designed with S-style ball nose geometry.
Reduce surface cutting resistance.
Good wear resistance and lubricating effect with
Nano multilayer coating
With MG carbide material is good for cutting
materials < 48HRC.

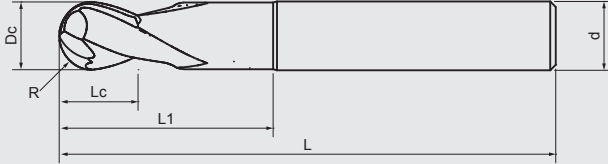

VHM
Carbide

AlTiCrN
HX



Steel
<48HRC



With sharp cutting edge is good for cutting
different steels below 48HRC as well as cast iron.
Application for finishing profile cutting.



DIN 6527 Standard Length

Dc 0 -0.02	R ±0.005	Lc mm	L mm	d h5	L1 mm	D1 mm	F623HX AlTiCrN					
1	0.5R	1	50	6	3	0.95	●					
1.5	0.75R	2	50	6	4	1.4	●					
2	1R	3	57	6	6	1.9	●					
3	1.5R	4	57	6	9	2.8	●					
4	2R	5	57	6	12	3.7	●					
5	2.5R	6	57	6	15	4.6	●					
6	3R	7	57	6	20	5.5	●					
8	4R	9	63	8	26	7.4	●					
10	5R	11	72	10	31	9.2	●					
12	6R	13	83	12	37	11	●					

Long Length

Dc 0 -0.02	R ±0.005	Lc mm	L mm	d h5	L1 mm	D1 mm		F624HX AlTiCrN				
3	1.5R	4	70	6	9	2.8		●				
4	2R	5	70	6	12	3.7		●				
5	2R	6	80	6	15	4.6		●				
6	3R	7	80	6	20	5.5		●				
8	4R	9	100	8	26	7.4		●				
10	5R	11	100	10	31	9.2		●				
12	6R	13	110	12	37	11		●				

Cutting Conditions

	F623HX				F624HX				
	cutting speed Vc (m/min)	feed per tooth fz(mm)	ae	ap	cutting speed Vc (m/min)	feed per tooth fz(mm)	ae	ap	
P	Carbon Steel Materials								
	GR1 Carbon Steel	120	0.02xDc	0.2xDc	0.1xDc	120	0.023xDc	0.2xDc	0.1xDc
	GR2 <24HRC Low-alloyed Steel	110	0.02xDc	0.2xDc	0.1xDc	110	0.022xDc	0.2xDc	0.1xDc
	GR3 <30HRC Hi-alloyed Steel	100	0.018xDc	0.2xDc	0.1xDc	100	0.021xDc	0.2xDc	0.1xDc
H	Hardened Steel Materials								
	GR4 30-38HRC Hardened Steel	60	0.015xDc	0.02xDc	0.02xDc	60	0.015xDc	0.02xDc	0.02xDc
	GR5 38-48HRC Hardened Steel	55	0.012xDc	0.02xDc	0.02xDc	55	0.012xDc	0.02xDc	0.02xDc
K	Cast Iron Materials								
	GR9-1 Grey cast iron	120	0.02xDc	0.2xDc	0.1xDc	120	0.023xDc	0.2xDc	0.1xDc
	GR9-2 Nodular cast iron	120	0.02xDc	0.2xDc	0.1xDc	120	0.023xDc	0.2xDc	0.1xDc

All cutting data serve for orientation only and should be adapted individually to the technical conditions on location

1. Please work with good rigidity / high precision facilities and collet chuck.
2. Please choose proper cutting fluid.
3. The cutting data is reference value only. Please adjust it according to your real working conditions.
4. If RPM is lower the reference value, the Feed rate [fz] and RPM should be reduced by the same proportion.
5. If vibration occurs during cutting, please reduce cutting parameter.

F625TX / F626TX

Ball Nose End Mills

Designed with S-style ball nose geometry.

Reduce surface cutting resistance.

Good wear resistance and lubricating effect with Nano multilayer coating

With SMG carbide material is good for cutting hardened materials < 70HRC.

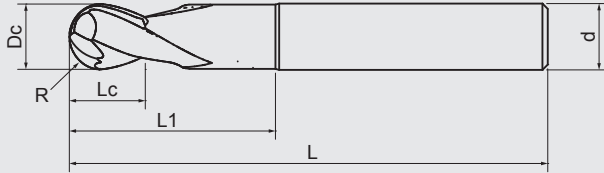

VHM
Carbide

AlTiSiN
TX



Steel
40-70
HRC

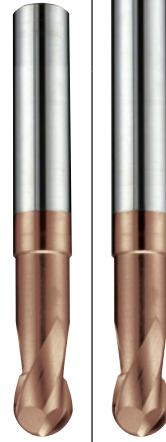

With stronger strength of cutting edge is suitable for hardened steels from 40-70HRC.

Application for finishing profile cutting.

H

H

DIN 6527 Standard Length

Dc 0 -0.02	R ±0.005	Lc mm	L mm	d h5	L1 mm	D1 mm	F625TX AlTiSiN					
1	0.5R	1	50	6	3	0.95	●					
1.5	0.75R	2	50	6	4	1.4	●					
2	1R	3	57	6	6	1.9	●					
3	1.5R	4	57	6	9	2.8	●					
4	2R	5	57	6	12	3.7	●					
5	2.5R	6	57	6	15	4.6	●					
6	3R	7	57	6	20	5.5	●					
8	4R	9	63	8	26	7.4	●					
10	5R	11	72	10	31	9.2	●					
12	6R	13	83	12	37	11	●					

Long Length

Dc 0 -0.02	R ±0.005	Lc mm	L mm	d h5	L1 mm	D1 mm		F626TX AlTiSiN				
3	1.5R	4	70	6	9	2.8		●				
4	2R	5	70	6	12	3.7		●				
5	2.5R	6	80	6	15	4.6		●				
6	3R	7	80	6	20	5.5		●				
8	4R	9	100	8	26	7.4		●				
10	5R	11	100	10	31	9.2		●				
12	6R	13	110	12	37	11		●				

Cutting Conditions

F625TX F626TX	F625TX				F626TX				
	cutting speed Vc (m/min)	feed per tooth fz(mm)	ae	ap	cutting speed Vc (m/min)	feed per tooth fz(mm)	ae	ap	
Hardened Steel Materials									
H	GR5 38-48HRC Hardened Steel	65	0.015xDc	0.02xDc	0.02xDc	65	0.015xDc	0.02xDc	0.02xDc
	GR6 48-56HRC Hardened Steel	60	0.012xDc	0.02xDc	0.02xDc	60	0.012xDc	0.02xDc	0.02xDc
	GR7 56-68HRC Hardened Steel	55	0.011xDc	0.02xDc	0.02xDc	55	0.011xDc	0.02xDc	0.02xDc

All cutting data serve for orientation only and should be adapted individually to the technical conditions on location

1. Please work with good rigidity / high precision facilities and collet chuck.
2. Please choose proper cutting fluid.
3. The cutting data is reference value only. Please adjust it according to your real working conditions.
4. If RPM is lower the reference value, the Feed rate (fz) and RPM should be reduced by the same proportion.
5. If vibration occurs during cutting, please reduce cutting parameter.

F615TX / F619TX

Toric End Mills

Honing cutting edge with AITiSiN Nano multilayer coating to improve tool life effectively.

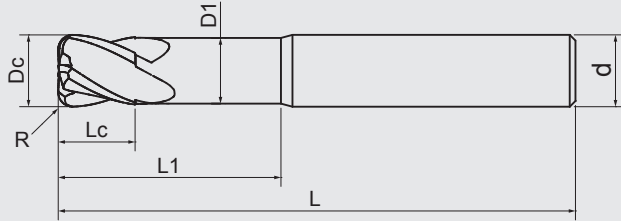

VHM Carbide
AITiSiN TX
 30°
 4
 75°
 R
Steel <62HRC

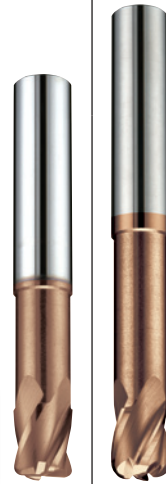

Suitable for profile surface machining, roughing and finishing in cutting different steel below 62HRC and cast Iron.

P P
H H
K K

DIN 6527 Standard Length

Dc 0 -0.02	R ±0.02	Lc mm	L mm	d h5	L1 mm	D1 mm	F615TX AITiSiN				
3	R0.3	4	57	6	14	2.8	●				
3	R0.5	4	57	6	14	2.8	●				
4	R0.3	5	57	6	16	3.7	●				
4	R0.5	5	57	6	16	3.7	●				
4	R1	5	57	6	16	3.7	●				
6	R0.5	7	57	6	20	5.5	●				
6	R1	7	57	6	20	5.5	●				
6	R1.5	7	57	6	20	5.5	●				
8	R0.5	9	63	8	26	7.4	●				
8	R1	9	63	8	26	7.4	●				
8	R1.5	9	63	8	26	7.4	●				
8	R2	9	63	8	26	7.4	●				
10	R0.5	11	72	10	31	9.2	●				
10	R1	11	72	10	31	9.2	●				
10	R1.5	11	72	10	31	9.2	●				
10	R2	11	72	10	31	9.2	●				
10	R2.5	11	72	10	31	9.2	●				
12	R0.5	13	83	12	37	11	●				
12	R1	13	83	12	37	11	●				
12	R1.5	13	83	12	37	11	●				
12	R2	13	83	12	37	11	●				
12	R3	13	83	12	37	11	●				
16	R2	17	92	16	43	14.5	●				
16	R4	17	92	16	43	14.5	●				

Long Length

Dc 0 -0.02	R ±0.02	Lc mm	L mm	d h5	L1 mm	D1 mm		F619TX AITiSiN			
6	R0.5	7	70	6	33	5.5		●			
6	R1	7	70	6	33	5.5		●			
6	R1.5	7	70	6	33	5.5		●			
8	R0.5	9	80	8	43	7.4		●			
8	R1	9	80	8	43	7.4		●			
8	R2	9	80	8	43	7.4		●			
10	R0.5	11	90	10	49	9.2		●			
10	R1	11	90	10	49	9.2		●			
10	R2	11	90	10	49	9.2		●			
10	R2.5	11	90	10	49	9.2		●			
12	R0.5	13	100	12	54	11		●			
12	R1	13	100	12	54	11		●			
12	R2	13	100	12	54	11		●			
12	R3	13	100	12	54	11		●			
16	R2	17	115	16	66	14.5		●			
16	R4	17	115	16	66	14.5		●			

Cutting Conditions

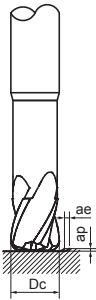
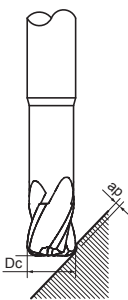
F615TX F619TX								
		cutting speed Vc (m/min)	feed per tooth fz(mm)	ae	ap	cutting speed Vc (m/min)	feed per tooth fz(mm)	ap
Carbon Steel Materials								
P	GR1 Carbon Steel	280	0.011xDc	0.4xDc	0.03xDc	360	0.008xDc	0.01xDc
	GR2 <24HRC Low-alloyed Steel	260	0.011xDc	0.4xDc	0.03xDc	320	0.008xDc	0.01xDc
	GR3 <30HRC Hi-alloyed Steel	230	0.009xDc	0.4xDc	0.03xDc	270	0.008xDc	0.01xDc
Hardened Steel Materials								
H	GR4 30-38HRC Hardened Steel	100	0.008xDc	0.4xDc	0.03xDc	180	0.006xDc	0.01xDc
	GR5 38-48HRC Hardened Steel	80	0.007xDc	0.3xDc	0.02xDc	160	0.005xDc	0.01xDc
	GR6 48-56HRC Hardened Steel	60	0.006xDc	0.2xDc	0.01xDc	140	0.004xDc	0.01xDc
Cast Iron Materials								
K	GR9-1 Grey cast iron	280	0.02xDc	0.4xDc	0.03xDc	360	0.008xDc	0.01xDc
	GR9-2 Nodular cast iron	250	0.02xDc	0.4xDc	0.03xDc	320	0.008xDc	0.01xDc

All cutting data serve for orientation only and should be adapted individually to the technical conditions on location

1. Please work with good rigidity / high precision facilities and collet chuck.
2. Please choose proper cutting fluid.
3. The cutting data is reference value only. Please adjust it according to your real working conditions.
4. If RPM is lower the reference value, the Feed rate (fz) and RPM should be reduced by the same proportion.
5. If vibration occurs during cutting, please reduce cutting parameter.

F613TX / F614TX

Toric End Mills

Design with high hardness, rigidity and negative rake angle.

Honing cutting edge with AlTiSiN Nano multilayer coating to improve tool life effectively.

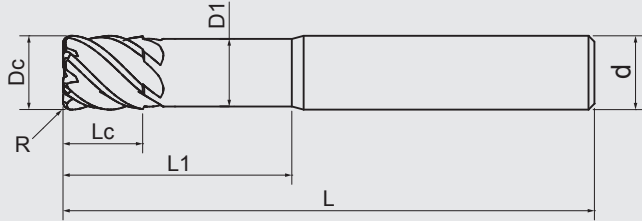

VHM
Carbide

AlTiSiN
TX

45°

6

N
7-10°

R

Steel
40-70
HRC



Suitable for profile surface machining, roughing and finishing in cutting different steel below 62HRC.

H
K

H
K

DIN 6527 Standard Length

Dc 0 -0.02	R 0 -0.02	Lc mm	L mm	d h5	L1 mm	D1 mm	Z	F613TX AlTiSiN					
3	R0.5	4	57	6	14	2.8	4	●					
4	R0.5	5	57	6	16	3.7	4	●					
5	R0.5	6	57	6	18	4.6	4	●					
6	R0.5	7	57	6	20	5.5	6	●					
8	R0.5	9	63	8	26	7.4	6	●					
10	R0.5	11	72	10	31	9.2	6	●					
12	R0.5	13	83	12	37	11	6	●					
6	R1	7	57	6	20	5.5	6	●					
8	R1	9	63	8	26	7.4	6	●					
10	R1	11	72	10	31	9.2	6	●					
12	R1	13	83	12	37	11	6	●					

Long Length

Dc 0 -0.02	R 0 -0.02	Lc mm	L mm	d h5	L1 mm	D1 mm	Z		F614TX AlTiSiN				
3	R0.5	4	70	6	27	2.8	4		●				
4	R0.5	5	70	6	29	3.7	4		●				
5	R0.5	6	70	6	31	4.6	4		●				
6	R0.5	7	70	6	33	5.5	6		●				
8	R0.5	9	80	8	43	7.4	6		●				
10	R0.5	11	90	10	49	9.2	6		●				
12	R0.5	13	100	12	54	11	6		●				
6	R1	7	70	6	33	5.5	6		●				
8	R1	9	80	8	43	7.4	6		●				
10	R1	11	90	10	49	9.2	6		●				
12	R1	13	100	12	54	11	6		●				

Cutting Conditions

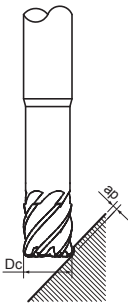
F613TX F614TX									
		cutting speed Vc (m/min)	feed per tooth fz(mm)	ae	ap	cutting speed Vc (m/min)	feed per tooth fz(mm)	ap	
Carbon Steel Materials									
P	GR1 Carbon Steel	280	0.011xDc	0.4xDc	0.03xDc	360	0.008xDc	0.01xDc	
	GR2 <24HRC Low-alloyed Steel	260	0.011xDc	0.4xDc	0.03xDc	320	0.008xDc	0.01xDc	
	GR3 <30HRC Hi-alloyed Steel	230	0.009xDc	0.4xDc	0.03xDc	270	0.008xDc	0.01xDc	
Hardened Steel Materials									
H	GR4 30-38HRC Hardened Steel	100	0.008xDc	0.4xDc	0.03xDc	180	0.006xDc	0.01xDc	
	GR5 38-48HRC Hardened Steel	80	0.007xDc	0.3xDc	0.02xDc	160	0.005xDc	0.01xDc	
	GR6 48-56HRC Hardened Steel	60	0.006xDc	0.2xDc	0.01xDc	140	0.004xDc	0.01xDc	
Cast Iron Materials									
K	GR9-1 Grey cast iron	280	0.02xDc	0.4xDc	0.03xDc	360	0.008xDc	0.01xDc	
	GR9-2 Nodular cast iron	250	0.02xDc	0.4xDc	0.03xDc	320	0.008xDc	0.01xDc	

All cutting data serve for orientation only and should be adapted individually to the technical conditions on location

1. Please work with good rigidity / high precision facilities and collet chuck.
2. Please choose proper cutting fluid.
3. The cutting data is reference value only. Please adjust it according to your real working conditions.
4. If RPM is lower the reference value, the Feed rate (fz) and RPM should be reduced by the same proportion.
5. If vibration occurs during cutting, please reduce cutting parameter.

F676TX

High Feed End Mills

Design with Special R curvature.

Honing cutting edge with AlTiSiN Nano multilayer coating to improve tool life effectively.

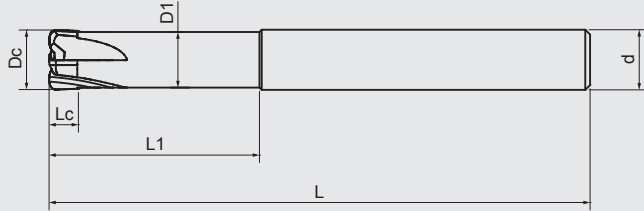

VHM
Carbide

AlTiSiN
TX



Steel
<62HRC



Suitable for profile surface machining, roughing in cutting different steel below 62HRC.



Long Length

Dc 0 -0.02	Programmable Radius	Lc mm	L mm	d h5	L1 mm	D1 mm	F676TX AlTiSiN					
3	0.37	2	70	6	12	2.8	●					
4	0.47	2	70	6	16	3.7	●					
5	0.60	2.5	70	6	20	4.6	●					
6	0.73	3	70	6	25	5.5	●					
8	0.98	4	80	8	30	7.4	●					
10	1.23	5	90	10	35	9.2	●					
12	1.65	6	100	12	40	11	●					

Cutting Conditions

F676TX					
	cutting speed Vc (m/min)	feed per tooth fz(mm)	ae	ap	
Carbon Steel Materials					
P	GR1 Carbon Steel	280	0.011xDc	0.4xDc	0.03xDc
	GR2 <24HRC Low-alloyed Steel	260	0.011xDc	0.4xDc	0.03xDc
	GR3 <30HRC Hi-alloyed Steel	230	0.009xDc	0.4xDc	0.03xDc
Hardened Steel Materials					
H	GR4 30-38HRC Hardened Steel	100	0.008xDc	0.4xDc	0.03xDc
	GR5 38-48HRC Hardened Steel	80	0.007xDc	0.3xDc	0.02xDc
	GR6 48-56HRC Hardened Steel	60	0.006xDc	0.2xDc	0.01xDc
	GR6 56-68HRC Hardened Steel	40	0.005xDc	0.15xDc	0.01xDc

All cutting data serve for orientation only and should be adapted individually to the technical conditions on location

1. Please work with good rigidity / high precision facilities and collet chuck.
2. Please choose proper cutting fluid.
3. The cutting data is reference value only. Please adjust it according to your real working conditions.
4. If RPM is lower the reference value, the Feed rate (fz) and RPM should be reduced by the same proportion.
5. If vibration occurs during cutting, please reduce cutting parameter.

Drills



Page	281	283	285	287	287	289
Apperance						
Code No	D903 D904 D913 D914	D908	D400	D412	D430FN	D413
Carbide	VHM Carbide	VHM Carbide	VHM Carbide	VHM Carbide	VHM Carbide	VHM Carbide
Coating	Uncoated Bright	Uncoated Bright	Uncoated Bright	Uncoated Bright	AlTiCrN FN	Uncoated Bright
Helix Angle						
No.of Flutes						

DIN

289 291 293 295 297 299

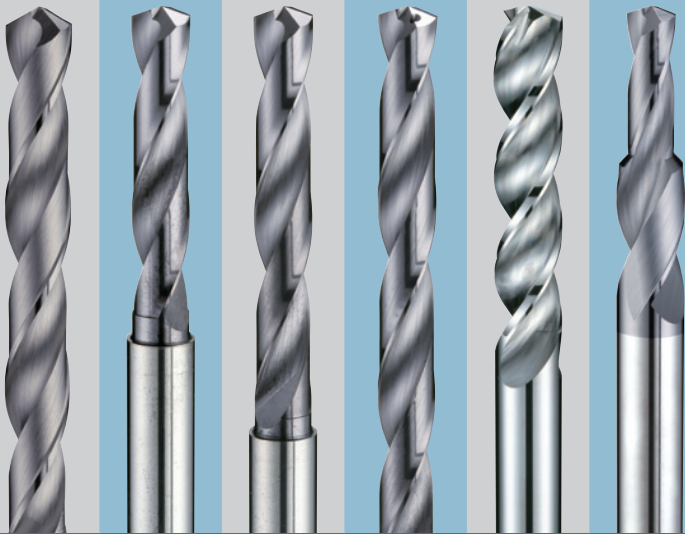

D433FN D431FT
D435FT D432FT
D436FT D437FT D415 D419FT

VHM Carbide VHM Carbide VHM Carbide VHM Carbide VHM Carbide VHM Carbide

AlTiCrN FN AlTiCrN FT AlTiCrN FT AlTiCrN FT Uncoated Bright AlTiCrN FT



D903 / D904 / D913 / D914

NC Spot Drills 90° / 120°

Two specifications of length.
Drill point angle 90° and 120°.

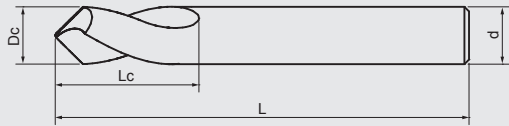
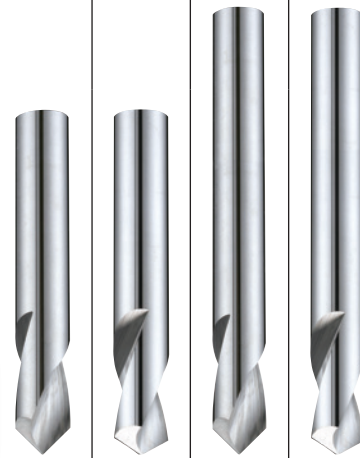
VHM
CarbideUncoated
BrightSteel
Cast Iron
AL. Copper

Improved strength design for cutting different
steels below 48HRC, cast iron, aluminium and
copper.

Application for drill positioning and chamfering.

P
H
K
N

P
H
K
N

P
H
K
N

P
H
K
N





Standard Length

Dc h6	Lc mm	L mm	d h6	D903 90°	D913 120°				
3	10	38	3	●	●				
4	12	50	4	●	●				
5	15	50	5	●	●				
6	20	60	6	●	●				
8	25	60	8	●	●				
10	25	72	10	●	●				
12	30	75	12	●	●				
16	35	100	16	●	●				
20	40	100	20	●	●				

Long Length

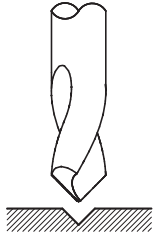
Dc h6	Lc mm	L mm	d h6			D904 90°	D914 120°		
6	20	100	6			●	●		
8	25	125	8			●	●		
10	25	150	10			●	●		
12	30	150	12			●	●		
16	35	150	16			●	●		
20	40	150	20			●	●		

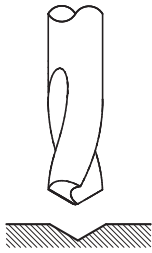
Cutting Conditions

	D903		D904		D913		D914		
									
	cutting speed Vc (m/min)	feed per tooth fz(mm)	cutting speed Vc (m/min)	feed per tooth fz(mm)	cutting speed Vc (m/min)	feed per tooth fz(mm)	cutting speed Vc (m/min)	feed per tooth fz(mm)	
Carbon Steel Materials									
P	GR1 Carbon Steel	70	0.004xDc	80	0.005xDc	70	0.004xDc	80	0.005xDc
	GR2 <24HRC Low-alloyed Steel	60	0.004xDc	70	0.005xDc	60	0.004xDc	70	0.005xDc
	GR3 <30HRC Hi-alloyed Steel	50	0.004xDc	60	0.004xDc	50	0.004xDc	60	0.004xDc
Hardened Steel Materials									
H	GR4 30-38HRC Hardened Steel	40	0.003xDc	35	0.003xDc	40	0.003xDc	35	0.003xDc
	GR5 38-48HRC Hardened Steel	30	0.002xDc	30	0.002xDc	30	0.002xDc	30	0.002xDc
Cast Iron Materials									
K	GR9-1 Grey cast iron	70	0.004xDc	80	0.005xDc	70	0.004xDc	80	0.005xDc
	GR9-2 Nodular cast iron	70	0.004xDc	80	0.005xDc	70	0.004xDc	80	0.005xDc
Aluminium Steel Materials									
N	GR10-1 Wrought Aluminium alloys	200	0.007xDc	200	0.007xDc	200	0.007xDc	200	0.007xDc
	GR10-2 Aluminium cast alloys <10%	200	0.007xDc	200	0.007xDc	200	0.007xDc	200	0.007xDc
	GR10-3 Aluminium cast alloys >10%	180	0.007xDc	180	0.007xDc	180	0.007xDc	180	0.007xDc
Copper Steel Materials									
N	GR11-1 Pure Copper	60	0.004xDc	70	0.005xDc	60	0.004xDc	70	0.005xDc
	GR11-2 Brass	70	0.004xDc	80	0.005xDc	70	0.004xDc	80	0.005xDc
	GR11-2 Bronze	60	0.004xDc	70	0.005xDc	60	0.004xDc	70	0.005xDc

All cutting data serve for orientation only and should be adapted individually to the technical conditions on location

1. Please work with good rigidity / high precision facilities and collet chuck.
2. Please choose proper cutting fluid.
3. The cutting data is reference value only. Please adjust it according to your real working conditions.
4. If RPM is lower the reference value, the Feed rate (fz) and RPM should be reduced by the same proportion.
5. If vibration occurs during cutting, please reduce cutting parameter.

D908

Combined Drills and Countersink 60°

60° Combined drill and countersink centre drill.

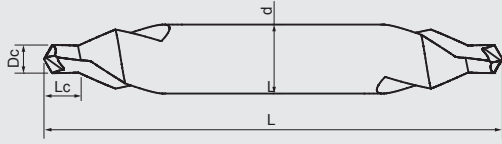
VHM
Carbide
Uncoated
Bright

DIN
333

Steel
Cast Iron
AL. Copper

Improved strength design for cutting different steels below 48HRC, cast iron, aluminium and copper.

Application for centre hole preparations for lathe and Cylindrical grinding.



DIN 333 Standard Length

Dc h7	Lc mm	L mm	d h5	D908 60°					
0.5	0.8	38	3	●					
0.8	1.1	38	3	●					
1	1.3	38	3	●					
1.25	1.6	38	3	●					
1.6	2	38	4	●					
2	2.5	50	5	●					
2.5	3.1	50	6	●					
3.15	3.9	63	8	●					
4	5	66	10	●					
5	6.3	73	12	●					

Cutting Conditions

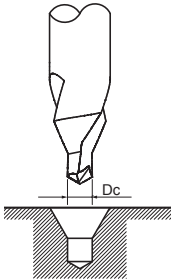
D908			
Carbon Steel Materials			
P	GR1 Carbon Steel	30	0.01xDc
	GR2 <24HRC Low-alloyed Steel	30	0.01xDc
	GR3 <30HRC Hi-alloyed Steel	20	0.01xDc
Hardened Steel Materials			
H	GR4 30-38HRC Hardened Steel	10	0.008xDc
	GR5 38-48HRC Hardened Steel	10	0.006xDc
Cast Iron Materials			
K	GR9-1 Grey cast iron	30	0.01xDc
	GR9-2 Nodular cast iron	35	0.01xDc
Aluminium Steel Materials			
N	GR10-1 Wrought Aluminium alloys	60	0.016xDc
	GR10-2 Aluminium cast alloys <10%	60	0.016xDc
	GR10-3 Aluminium cast alloys >10%	55	0.014xDc
Copper Steel Materials			
N	GR11-1 Pure Copper	30	0.01xDc
	GR11-2 Brass	30	0.01xDc
	GR11-2 Bronze	30	0.01xDc

All cutting data serve for orientation only and should be adapted individually to the technical conditions on location

1. Please work with good rigidity / high precision facilities and collet chuck.
2. Please choose proper cutting fluid.
3. The cutting data is reference value only. Please adjust it according to your real working conditions.
4. If RPM is lower the reference value, the Feed rate (fz) and RPM should be reduced by the same proportion.
5. If vibration occurs during cutting, please reduce cutting parameter.

D400

Micro Precision Drills

Small diameter with drill point angle 130°
 Design with sharp and strength drill point shape.
 Diameter specification from 0.2mm to 1.4mm in
 step of 0.05mm.

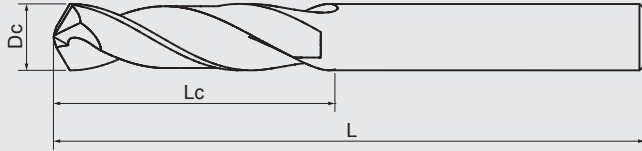

VHM
Carbide

Uncoated
Bright



DIN
1899



AL, Cu,
PVC,
Copper



Application for drilling aluminium, copper, plastic
 materials...and etc.



Standard Length

Dc h7	Lc mm	L mm	d h6	D400 Bright					
0.2	1.2	25	1	●					
0.25	1.5	25	1	●					
0.3	1.9	25	1	●					
0.35	2.4	25	1	●					
0.4	3	25	1	●					
0.45	3	25	1	●					
0.5	3.4	25	1	●					
0.55	3.9	25	1	●					
0.6	3.9	25	1	●					
0.65	4.2	25	1	●					
0.7	4.8	25	1	●					
0.75	4.8	25	1	●					
0.8	5.3	25	1.5	●					
0.85	5.3	25	1.5	●					
0.9	6	25	1.5	●					
0.95	6	25	1.5	●					
1	6.8	25	1.5	●					
1.05	6.8	25	1.5	●					
1.1	7.6	25	1.5	●					
1.15	7.6	25	1.5	●					
1.2	8.5	25	1.5	●					
1.25	8.5	25	1.5	●					
1.3	8.5	25	1.5	●					
1.35	9.5	25	1.5	●					
1.4	9.5	25	1.5	●					

Cutting Conditions

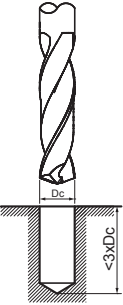
D400			
Carbon Steel Materials			
P	GRI Carbon Steel	40	0.008xDc
	GR2 <24HRC Low-alloyed Steel	30	0.008xDc
	GR3 <30HRC Hi-alloyed Steel	20	0.008xDc
Cast Iron Materials			
K	GR9-1 Grey cast iron	40	0.008xDc
	GR9-2 Nodular cast iron	40	0.008xDc
Aluminium Steel Materials			
	GR10-1 Wrought Aluminium alloys	200	0.01xDc
	GR10-2 Aluminium cast alloys <10%	200	0.01xDc
	GR10-3 Aluminium cast alloys >10%	180	0.01xDc
Copper Steel Materials			
N	GR11-1 Pure Copper	60	0.01xDc
	GR11-2 Brass	60	0.01xDc
	GR11-2 Bronze	60	0.01xDc
Plastics Steel Materials			
	GR12 Plastics	100	0.01xDc
FRP CFRP Steel Materials			
	GR13 FRP CFRP Composite Material	80	0.01xDc

All cutting data serve for orientation only and should be adapted individually to the technical conditions on location

1. Please work with good rigidity / high precision facilities and collet chuck.
2. Please choose proper cutting fluid.
3. The cutting data is reference value only. Please adjust it according to your real working conditions.
4. If RPM is lower the reference value, the Feed rate (fz) and RPM should be reduced by the same proportion.
5. If vibration occurs during cutting, please reduce cutting parameter.

D412 / D430FN

Twist Drills / High Performance Drills

D412 118° X-type drill point design is easy for positioning.

Designed with sharp drill point.

D430FN 140° S-type drill point design with centring and positioning function, reduce axial drilling force.

Designed with high chip evacuating flutes.

Good wear resistance and lubricating effect with Nano multilayer coating.

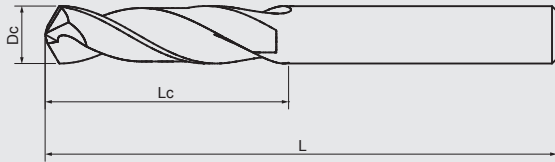

VHM
Carbide



DIN
6539



Suitable for drilling with 3XD depth.

D412 Application for drilling cast iron, aluminium, copper, plastic, composite materials...and etc.

D430FN Application for drilling steels below 48HRC, cast iron...and etc.

K
N

Uncoated
Bright
118°
AL, Cu,
PVC,
CFRP

P
H
K

AlTiCrN
FN
140°
Steel
<48HRC
Stainless
Cast Iron

DIN 6539 Stub Length

Dc h7	Lc mm	L mm	D412 Bright	D430FN AlTiCrN
1	6	26	●	●
1.05	6	26	●	●
1.1	7	28	●	●
1.15	7	28	●	●
1.2	8	30	●	●
1.25	8	30	●	●
1.3	8	30	●	●
1.35	9	32	●	●
1.4	9	32	●	●
1.45	9	32	●	●
1.5	9	32	●	●
1.55	10	34	●	●
1.6	10	34	●	●
1.65	10	34	●	●
1.7	10	34	●	●
1.75	11	36	●	●
1.8	11	36	●	●
1.85	11	36	●	●
1.9	11	36	●	●
1.95	12	38	●	●
2	12	38	●	●
2.05	12	38	●	●
2.1	12	38	●	●
2.15	13	40	●	●
2.2	13	40	●	●
2.25	13	40	●	●
2.3	13	40	●	●
2.35	13	40	●	●
2.4	14	43	●	●
2.45	14	43	●	●
2.5	14	43	●	●
2.55	14	43	●	●
2.6	14	43	●	●
2.65	14	43	●	●
2.7	16	46	●	●
2.75	16	46	●	●
2.8	16	46	●	●
2.85	16	46	●	●
2.9	16	46	●	●
2.95	16	46	●	●
3	16	46	●	●
3.1	18	49	●	●
3.2	18	49	●	●
3.3	18	49	●	●

Twist Drills / High Performance Drills

Dc h7	Lc mm	L mm	D412 Bright	D430FN AlTiCrN
3.4	20	52	●	●
3.5	20	52	●	●
3.6	20	52	●	●
3.7	20	52	●	●
3.8	22	55	●	●
3.9	22	55	●	●
4	22	55	●	●
4.1	22	55	●	●
4.2	22	55	●	●
4.3	24	58	●	●
4.4	24	58	●	●
4.5	24	58	●	●
4.6	24	58	●	●
4.7	24	58	●	●
4.8	26	62	●	●
4.9	26	62	●	●
5	26	62	●	●
5.1	26	62	●	●
5.2	26	62	●	●
5.3	26	62	●	●
5.4	28	66	●	●
5.5	28	66	●	●
5.6	28	66	●	●
5.7	28	66	●	●
5.8	28	66	●	●
5.9	28	66	●	●
6	28	66	●	●
6.1	31	70	●	●
6.2	31	70	●	●
6.3	31	70	●	●
6.4	31	70	●	●
6.5	31	70	●	●
6.6	31	70	●	●
6.7	31	70	●	●
6.8	34	74	●	●
6.9	34	74	●	●
7	34	74	●	●
7.1	34	74	●	●
7.2	34	74	●	●
7.3	34	74	●	●
7.4	34	74	●	●
7.5	34	74	●	●
7.6	37	79	●	●
7.7	37	79	●	●
7.8	37	79	●	●
7.9	37	79	●	●
8	37	79	●	●
8.1	37	79	●	●
8.2	37	79	●	●
8.3	37	79	●	●
8.4	37	79	●	●
8.5	37	79	●	●
8.6	40	84	●	●
8.7	40	84	●	●
8.8	40	84	●	●
8.9	40	84	●	●
9	40	84	●	●
9.1	40	84	●	●
9.2	40	84	●	●
9.3	40	84	●	●
9.4	40	84	●	●
9.5	40	84	●	●
9.6	43	89	●	●
9.7	43	89	●	●
9.8	43	89	●	●
9.9	43	89	●	●
10	43	89	●	●
10.2	43	89	●	●
10.5	43	89	●	●
10.8	47	95	●	●
11	47	95	●	●
11.5	47	95	●	●
12	51	102	●	●
12.5	51	102	●	●
13	51	102	●	●

Please refer to page 300 for parameters.

D413 / D433FN

Twist Drills / High Performance Drills

D413 118° X-type drill point design is easy for positioning.

Designed with sharp drill point.

D433FN 140° S-type drill point design with centring and positioning function, reduce axial drilling force.

Designed with high chip evacuating flutes.

Good wear resistance and lubricating effect with Nano multilayer coating.

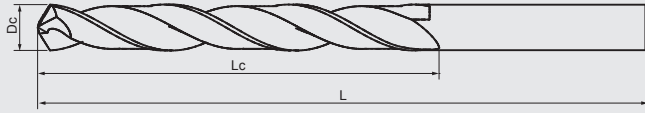

VHM
Carbide



DIN
338



Suitable for drilling with 5XD depth.

D413 Application for drilling cast iron, aluminium, copper, plastic, composite materials...and etc.

D433FN Application for drilling steels below 48HRC, cast iron...and etc.

K
N

Uncoated
Bright
118°
AL, Cu,
PVC,
CFRP

P
H
K

AlTiCrN
FN
140°
Steel
<48HRC
Stainless
Cast Iron

DIN 338 Standard Length

Dc h7	Lc mm	L mm	D413 Bright	D433FN AlTiCrN
1	12	34	●	●
1.1	14	36	●	●
1.2	16	38	●	●
1.3	16	38	●	●
1.4	18	40	●	●
1.5	18	40	●	●
1.6	20	43	●	●
1.7	20	43	●	●
1.8	22	46	●	●
1.9	22	46	●	●
2	24	49	●	●
2.1	24	49	●	●
2.2	27	53	●	●
2.3	27	53	●	●
2.4	30	57	●	●
2.5	30	57	●	●
2.6	30	57	●	●
2.7	33	61	●	●
2.8	33	61	●	●
2.9	33	61	●	●
3	33	61	●	●
3.1	36	65	●	●
3.2	36	65	●	●
3.3	36	65	●	●
3.4	39	70	●	●
3.5	39	70	●	●
3.6	39	70	●	●
3.7	39	70	●	●
3.8	43	75	●	●
3.9	43	75	●	●
4	43	75	●	●
4.1	43	75	●	●
4.2	43	75	●	●
4.3	47	80	●	●
4.4	47	80	●	●
4.5	47	80	●	●
4.6	47	80	●	●
4.7	47	80	●	●
4.8	52	86	●	●
4.9	52	86	●	●

Twist Drills / High Performance Drills

Dc h7	Lc mm	L mm	D413 Bright	D433FN AlTiCrN	
5	52	86	●	●	
5.1	52	86	●	●	
5.2	52	86	●	●	
5.3	52	86	●	●	
5.4	57	93	●	●	
5.5	57	93	●	●	
5.6	57	93	●	●	
5.7	57	93	●	●	
5.8	57	93	●	●	
5.9	57	93	●	●	
6	57	93	●	●	
6.1	63	101	●	●	
6.2	63	101	●	●	
6.3	63	101	●	●	
6.4	63	101	●	●	
6.5	63	101	●	●	
6.6	63	101	●	●	
6.7	63	101	●	●	
6.8	69	109	●	●	
6.9	69	109	●	●	
7	69	109	●	●	
7.1	69	109	●	●	
7.2	69	109	●	●	
7.3	69	109	●	●	
7.4	69	109	●	●	
7.5	69	109	●	●	
7.6	75	117	●	●	
7.7	75	117	●	●	
7.8	75	117	●	●	
7.9	75	117	●	●	
8	75	117	●	●	
8.1	75	117	●	●	
8.2	75	117	●	●	
8.3	75	117	●	●	
8.4	75	117	●	●	
8.5	75	117	●	●	
8.6	81	125	●	●	
8.7	81	125	●	●	
8.8	81	125	●	●	
8.9	81	125	●	●	
9	81	125	●	●	
9.1	81	125	●	●	
9.2	81	125	●	●	
9.3	81	125	●	●	
9.4	81	125	●	●	
9.5	81	125	●	●	
9.6	87	133	●	●	
9.7	87	133	●	●	
9.8	87	133	●	●	
9.9	87	133	●	●	
10	87	133	●	●	
10.2	87	133	●	●	
10.5	87	133	●	●	
10.8	94	142	●	●	
11	94	142	●	●	
11.5	94	142	●	●	
12	101	151	●	●	
12.5	101	151	●	●	
13	101	151	●	●	

Please refer to page 300 for parameters.

D431FT / D435FT

High Performance Drills / Oil-Feed High Performance Drills

140° S-type drill point design with centring and positioning function, reduce axial drilling force.
Designed with high chip evacuating flutes.
Good wear resistance and lubricating effect with Nano multilayer coating.
D435FT Oil-feed design for internal coolant supply.

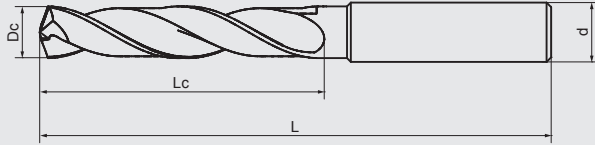

VHM
Carbide

AlTiCrN
FT



DIN
6537K



Steel
<48HRC
Stainless
Cast Iron



Application for drilling steels below 48HRC, cast iron...and etc.
Suitable for drilling with 3XD depth.

P
H
K



P
H
M
K



DIN 6537K Stub Length

Dc m7	Lc mm	L mm	d h6	D431FT AlTiCrN	D435FT AlTiCrN
3	20	62	6	●	●
3.1	20	62	6	●	●
3.2	20	62	6	●	●
3.3	20	62	6	●	●
3.4	20	62	6	●	●
3.5	20	62	6	●	●
3.6	20	62	6	●	●
3.7	20	62	6	●	●
3.8	24	66	6	●	●
3.9	24	66	6	●	●
4	24	66	6	●	●
4.1	24	66	6	●	●
4.2	24	66	6	●	●
4.3	24	66	6	●	●
4.4	24	66	6	●	●
4.5	24	66	6	●	●
4.6	24	66	6	●	●
4.7	24	66	6	●	●
4.8	28	66	6	●	●
4.9	28	66	6	●	●
5	28	66	6	●	●
5.1	28	66	6	●	●
5.2	28	66	6	●	●
5.3	28	66	6	●	●
5.4	28	66	6	●	●
5.5	28	66	6	●	●
5.6	28	66	6	●	●
5.7	28	66	6	●	●
5.8	28	66	6	●	●
5.9	28	66	6	●	●
6	28	66	6	●	●
6.1	34	79	8	●	●
6.2	34	79	8	●	●
6.3	34	79	8	●	●
6.4	34	79	8	●	●
6.5	34	79	8	●	●
6.6	34	79	8	●	●
6.7	34	79	8	●	●

D431FT / D435FT

High Performance Drills / Oil-Feed High Performance Drills

Dc m7	Lc mm	L mm	d h6	D431FT AlTiCrN	D435FT AlTiCrN	
6.8	34	79	8	●	●	
6.9	34	79	8	●	●	
7	34	79	8	●	●	
7.1	41	79	8	●	●	
7.2	41	79	8	●	●	
7.3	41	79	8	●	●	
7.4	41	79	8	●	●	
7.5	41	79	8	●	●	
7.6	41	79	8	●	●	
7.7	41	79	8	●	●	
7.8	41	79	8	●	●	
7.9	41	79	8	●	●	
8	41	79	8	●	●	
8.1	47	89	10	●	●	
8.2	47	89	10	●	●	
8.3	47	89	10	●	●	
8.4	47	89	10	●	●	
8.5	47	89	10	●	●	
8.6	47	89	10	●	●	
8.7	47	89	10	●	●	
8.8	47	89	10	●	●	
8.9	47	89	10	●	●	
9	47	89	10	●	●	
9.1	47	89	10	●	●	
9.2	47	89	10	●	●	
9.3	47	89	10	●	●	
9.4	47	89	10	●	●	
9.5	47	89	10	●	●	
9.6	47	89	10	●	●	
9.7	47	89	10	●	●	
9.8	47	89	10	●	●	
9.9	47	89	10	●	●	
10	47	89	10	●	●	
10.1	55	102	12	●	●	
10.2	55	102	12	●	●	
10.5	55	102	12	●	●	
10.8	55	102	12	●	●	
11	55	102	12	●	●	
11.5	55	102	12	●	●	
12	55	102	12	●	●	
12.5	60	107	14	●	●	
13	60	107	14	●	●	
13.5	60	107	14	●	●	
14	60	107	14	●	●	
14.5	65	115	16	●	●	
15	65	115	16	●	●	
15.5	65	115	16	●	●	
16	65	115	16	●	●	
16.5	73	123	18	●	●	
17	73	123	18	●	●	
17.5	73	123	18	●	●	
18	73	123	18	●	●	
18.5	79	131	20	●	●	
19	79	131	20	●	●	
19.5	79	131	20	●	●	
20	79	131	20	●	●	

Please refer to page 301 for parameters.

D432FT / D436FT

High Performance Drills / Oil-Feed High Performance Drills

140° S-type drill point design with centring and positioning function, reduce axial drilling force.
Designed with high chip evacuating flutes.
Good wear resistance and lubricating effect with Nano multilayer coating.
D436FT Oil-feed design for internal coolant supply.

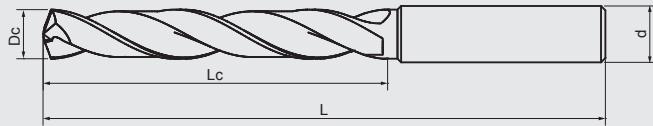

VHM
Carbide

AlTiCrN
FT



DIN
6537L



Steel
<48HRC
Stainless
Cast Iron



Application for drilling steels below 48HRC, cast iron...and etc.
Suitable for drilling with 5XD depth.

P
H
K



P
H
M
K



DIN 6537L Standard Length

Dc m7	Lc mm	L mm	d h6	D432FT AlTiCrN	D436FT AlTiCrN
3	28	66	6	●	●
3.1	28	66	6	●	●
3.2	28	66	6	●	●
3.3	28	66	6	●	●
3.4	28	66	6	●	●
3.5	28	66	6	●	●
3.6	28	66	6	●	●
3.7	28	66	6	●	●
3.8	36	74	6	●	●
3.9	36	74	6	●	●
4	36	74	6	●	●
4.1	36	74	6	●	●
4.2	36	74	6	●	●
4.3	36	74	6	●	●
4.4	36	74	6	●	●
4.5	36	74	6	●	●
4.6	36	74	6	●	●
4.7	36	74	6	●	●
4.8	44	82	6	●	●
4.9	44	82	6	●	●
5	44	82	6	●	●
5.1	44	82	6	●	●
5.2	44	82	6	●	●
5.3	44	82	6	●	●
5.4	44	82	6	●	●
5.5	44	82	6	●	●
5.6	44	82	6	●	●
5.7	44	82	6	●	●
5.8	44	82	6	●	●
5.9	44	82	6	●	●
6	44	82	6	●	●
6.1	53	91	8	●	●
6.2	53	91	8	●	●
6.3	53	91	8	●	●
6.4	53	91	8	●	●
6.5	53	91	8	●	●
6.6	53	91	8	●	●
6.7	53	91	8	●	●

D432FT / D436FT

High Performance Drills / Oil-Feed High Performance Drills

Dc m7	Lc mm	L mm	d h6	D432FT AlTiCrN	D436FT AlTiCrN	
6.8	53	91	8	●	●	
6.9	53	91	8	●	●	
7	53	91	8	●	●	
7.1	53	91	8	●	●	
7.2	53	91	8	●	●	
7.3	53	91	8	●	●	
7.4	53	91	8	●	●	
7.5	53	91	8	●	●	
7.6	53	91	8	●	●	
7.7	53	91	8	●	●	
7.8	53	91	8	●	●	
7.9	53	91	8	●	●	
8	53	91	8	●	●	
8.1	61	103	10	●	●	
8.2	61	103	10	●	●	
8.3	61	103	10	●	●	
8.4	61	103	10	●	●	
8.5	61	103	10	●	●	
8.6	61	103	10	●	●	
8.7	61	103	10	●	●	
8.8	61	103	10	●	●	
8.9	61	103	10	●	●	
9	61	103	10	●	●	
9.1	61	103	10	●	●	
9.2	61	103	10	●	●	
9.3	61	103	10	●	●	
9.4	61	103	10	●	●	
9.5	61	103	10	●	●	
9.6	61	103	10	●	●	
9.7	61	103	10	●	●	
9.8	61	103	10	●	●	
9.9	61	103	10	●	●	
10	61	103	10	●	●	
10.1	71	118	12	●	●	
10.2	71	118	12	●	●	
10.5	71	118	12	●	●	
10.8	71	118	12	●	●	
11	71	118	12	●	●	
11.5	71	118	12	●	●	
12	71	118	12	●	●	
12.5	77	124	14	●	●	
13	77	124	14	●	●	
13.5	77	124	14	●	●	
14	77	124	14	●	●	
14.5	83	133	16	●	●	
15	83	133	16	●	●	
15.5	83	133	16	●	●	
16	83	133	16	●	●	
16.5	93	143	18	●	●	
17	93	143	18	●	●	
17.5	93	143	18	●	●	
18	93	143	18	●	●	
18.5	101	153	20	●	●	
19	101	153	20	●	●	
19.5	101	153	20	●	●	
20	101	153	20	●	●	

Please refer to page 301 for parameters.

D437FT

Oil-Feed High Performance Drills

140° S-type drill point design with centring and positioning function, reduce axial drilling force.
Designed with high chip evacuating flutes.
Oil-feed design for internal coolant supply.
Good wear resistance and lubricating effect with Nano multilayer coating.

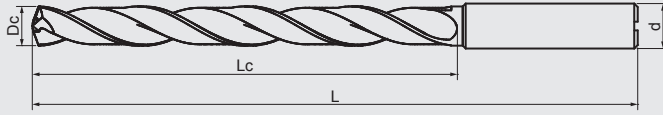

VHM
Carbide

AlTiCrN
FT



Steel
<48HRC
Stainless
Cast Iron



Application for drilling steels below 48HRC, cast iron...and etc.
Suitable for drilling with 8XD depth.

P
H
M
K



Long Length

Dc m7	Lc mm	L mm	d h6	D437FT AlTiCrN		
3	34	74	6	●		
3.1	34	74	6	●		
3.2	34	74	6	●		
3.3	34	74	6	●		
3.4	34	74	6	●		
3.5	34	74	6	●		
3.6	34	74	6	●		
3.7	34	74	6	●		
3.8	45	85	6	●		
3.9	45	85	6	●		
4	45	85	6	●		
4.1	45	85	6	●		
4.2	45	85	6	●		
4.3	45	85	6	●		
4.4	45	85	6	●		
4.5	45	85	6	●		
4.6	45	85	6	●		
4.7	45	85	6	●		
4.8	57	97	6	●		
4.9	57	97	6	●		
5	57	97	6	●		
5.1	57	97	6	●		
5.2	57	97	6	●		
5.3	57	97	6	●		
5.4	57	97	6	●		
5.5	57	97	6	●		
5.6	57	97	6	●		
5.7	57	97	6	●		
5.8	57	97	6	●		
5.9	57	97	6	●		
6	57	97	6	●		
6.1	66	106	8	●		
6.2	66	106	8	●		
6.3	66	106	8	●		
6.4	66	106	8	●		
6.5	66	106	8	●		
6.6	66	106	8	●		
6.7	66	106	8	●		

D437FT

Oil-Feed High Performance Drills

Dc m7	Lc mm	L mm	d h6	D437FT AlTiCrN		
6.8	66	106	8	●		
6.9	66	106	8	●		
7	66	106	8	●		
7.1	76	116	8	●		
7.2	76	116	8	●		
7.3	76	116	8	●		
7.4	76	116	8	●		
7.5	76	116	8	●		
7.6	76	116	8	●		
7.7	76	116	8	●		
7.8	76	116	8	●		
7.9	76	116	8	●		
8	76	116	8	●		
8.1	95	139	10	●		
8.2	95	139	10	●		
8.3	95	139	10	●		
8.4	95	139	10	●		
8.5	95	139	10	●		
8.6	95	139	10	●		
8.7	95	139	10	●		
8.8	95	139	10	●		
8.9	95	139	10	●		
9	95	139	10	●		
9.1	95	139	10	●		
9.2	95	139	10	●		
9.3	95	139	10	●		
9.4	95	139	10	●		
9.5	95	139	10	●		
9.6	95	139	10	●		
9.7	95	139	10	●		
9.8	95	139	10	●		
9.9	95	139	10	●		
10	95	139	10	●		
10.2	114	163	12	●		
10.5	114	163	12	●		
10.8	114	163	12	●		
11	114	163	12	●		
11.5	114	163	12	●		
12	114	163	12	●		
12.5	133	182	14	●		
13	133	182	14	●		
13.5	133	182	14	●		
14	133	182	14	●		
14.5	152	204	16	●		
15	152	204	16	●		
15.5	152	204	16	●		
16	152	204	16	●		
16.5	171	223	18	●		
17	171	223	18	●		
17.5	171	223	18	●		
18	171	223	18	●		
18.5	190	244	20	●		
19	190	244	20	●		
19.5	190	244	20	●		
20	190	244	20	●		

Please refer to page 302 for parameters.

D415

High Performance 3-Flute Drills

DIN 5XD Drills-3 Flutes

Designed with high chip evacuating flutes.

To provide higher drilling and milling rate and improve stability on drilling performance.

Suitable for drilling with 5XD depth.

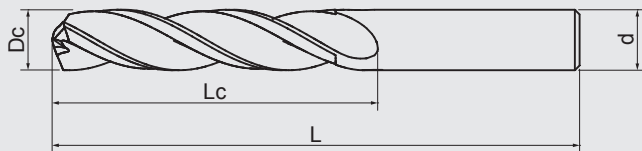
VHM
Carbide
Uncoated
Bright

DIN
6539

AL, Cu,
Copper

Improved strength design for cutting different steels below 48HRC, cast iron, aluminium and copper.

Application for drill positioning and chamfering.

P
K
N

Standard Length

Dc h7	Lc mm	L mm	D415 Bright
3	22	46	●
3.1	24	49	●
3.2	24	49	●
3.3	24	49	●
3.4	27	52	●
3.5	27	52	●
3.6	27	52	●
3.7	27	52	●
3.8	30	55	●
3.9	30	55	●
4	30	55	●
4.1	30	55	●
4.2	30	55	●
4.3	32	58	●
4.4	32	58	●
4.5	32	58	●
4.6	32	58	●
4.7	32	58	●
4.8	35	62	●
4.9	35	62	●
5	35	62	●
5.1	35	62	●
5.2	35	62	●
5.3	35	62	●
5.4	39	66	●
5.5	39	66	●
5.6	39	66	●
5.7	39	66	●
5.8	39	66	●
5.9	39	66	●
6	39	66	●
6.1	42	70	●
6.2	42	70	●
6.3	42	70	●
6.4	42	70	●
6.5	42	70	●
6.6	42	70	●
6.7	42	70	●
6.8	45	74	●
6.9	45	74	●
7	45	74	●

High Performance 3-Flute Drills

Dc h7	Lc mm	L mm	D415 Bright		
7.1	45	74	●		
7.2	45	74	●		
7.3	45	74	●		
7.4	45	74	●		
7.5	45	74	●		
7.6	48	79	●		
7.7	48	79	●		
7.8	48	79	●		
7.9	48	79	●		
8	48	79	●		
8.1	48	79	●		
8.2	48	79	●		
8.3	48	79	●		
8.4	48	79	●		
8.5	48	79	●		
8.6	52	84	●		
8.7	52	84	●		
8.8	52	84	●		
8.9	52	84	●		
9	52	84	●		
9.1	52	84	●		
9.2	52	84	●		
9.3	52	84	●		
9.4	52	84	●		
9.5	52	84	●		
9.6	55	89	●		
9.7	55	89	●		
9.8	55	89	●		
9.9	55	89	●		
10	55	89	●		
10.2	55	89	●		
10.5	55	89	●		
11	60	95	●		
11.5	60	95	●		
11.8	65	102	●		
12	65	102	●		
12.5	65	102	●		
13	65	102	●		

Please refer to page 302 for parameters.

D419FT

Combined Drill and Chamfer Tool

140° Step Drills

Design for pre-drilling diameter of Metric Thread, and drilling with chamfering 90° at once.

Good wear resistance and lubricating effect with Nano multilayer coating.

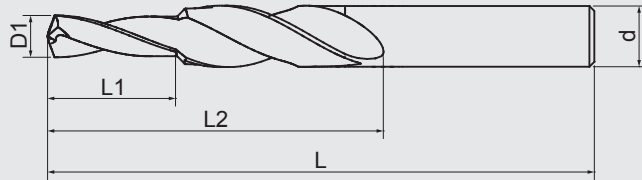

VHM
Carbide

AlTiCrN
FT



Steel
<48HRC



Application for drilling steels below 48HRC, cast iron...and etc.



DIN 6527 Standard Length

For thread size	D1 mm	L1 mm	L2 mm	L mm	d h6	D419FT AlTiCrN		
M 3	2.5	8.8	28	66	6	●		
M 4	3.3	11.4	28	66	6	●		
M 5	4.2	13.6	28	66	6	●		
M 6	5	16.5	41	79	8	●		
M 8	6.8	21	47	89	10	●		
M10	8.5	25.5	55	102	12	●		
M12	10.2	30	60	107	14	●		

Please refer to page 302 for parameters.



Cutting Conditions

	D412		D430FN		D413		D433FN		
	cutting speed Vc (m/min)	feed per tooth fz (mm)	cutting speed Vc (m/min)	feed per tooth fz (mm)	cutting speed Vc (m/min)	feed per tooth fz (mm)	cutting speed Vc (m/min)	feed per tooth fz (mm)	
D412 D430FN D413 D433FN									
	Carbon Steel Materials								
	P	GR1 Carbon Steel		80	0.023xDc			80	0.023xDc
		GR2 <24HRC Low-alloyed Steel		80	0.023xDc			80	0.023xDc
GR3 <30HRC Hi-alloyed Steel			70	0.021xDc			70	0.021xDc	
Hardened Steel Materials									
H	GR4 30-38HRC Hardened Steel		50	0.020xDc			50	0.020xDc	
	GR5 38-48HRC Hardened Steel		40	0.015xDc			40	0.015xDc	
Stainless Steel Materials									
M	GR8-1 Ferritic \ Martensitic								
	GR8-2 Austenitic								
	GR8-3 Austenitic-ferritic								
	GR8-4 Austenitic-ferritic Heat-resistant								
Cast Iron Materials									
K	GR9-1 Grey cast iron	40	0.008xDc	80	0.023xDc	40	0.008xDc	80	0.023xDc
	GR9-2 Nodular cast iron	40	0.008xDc	80	0.023xDc	40	0.008xDc	80	0.023xDc
Aluminium Steel Materials									
	GR10-1 Wrought Aluminium alloys	200	0.01xDc			200	0.01xDc		
	GR10-2 Aluminium cast alloys <10%	200	0.01xDc			200	0.01xDc		
	GR10-3 Aluminium cast alloys >10%	180	0.01xDc			180	0.01xDc		
Copper Steel Materials									
N	GR11-1 Pure Copper	60	0.01xDc			60	0.01xDc		
	GR11-2 Brass	60	0.01xDc			60	0.01xDc		
	GR11-2 Bronze	60	0.01xDc			60	0.01xDc		
Copper Steel Materials									
	GR12 Plastics	100	0.01xDc			100	0.01xDc		
	GR13 FRP CFRP Composite Material	80	0.01xDc			80	0.01xDc		

All cutting data serve for orientation only and should be adapted individually to the technical conditions on location

1. Please work with good rigidity / high precision facilities and collet chuck.
2. Please choose proper cutting fluid.
3. The cutting data is reference value only. Please adjust it according to your real working conditions.
4. If RPM is lower the reference value, the Feed rate (fz) and RPM should be reduced by the same proportion.
5. If vibration occurs during cutting, please reduce cutting parameter.

Cutting Conditions

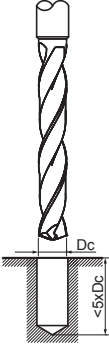
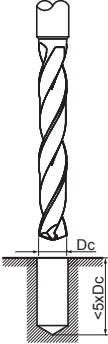
Cutting Conditions										
	D431FT		D435FT		D432FT		D436FT			
										
	cutting speed Vc (m/min)	feed per tooth fz (mm)	cutting speed Vc (m/min)	feed per tooth fz (mm)	cutting speed Vc (m/min)	feed per tooth fz (mm)	cutting speed Vc (m/min)	feed per tooth fz (mm)	cutting speed Vc (m/min)	feed per tooth fz (mm)
Carbon Steel Materials										
P	GR1 Carbon Steel	80	0.023xDc	100	0.023xDc	70	0.023xDc	100	0.023xDc	
	GR2 <24HRC Low-alloyed Steel	80	0.023xDc	100	0.023xDc	70	0.023xDc	100	0.023xDc	
	GR3 <30HRC Hi-alloyed Steel	70	0.021xDc	90	0.021xDc	60	0.021xDc	90	0.021xDc	
Hardened Steel Materials										
H	GR4 30-38HRC Hardened Steel	50	0.020xDc	50	0.020xDc	40	0.020xDc	50	0.020xDc	
	GR5 38-48HRC Hardened Steel	40	0.015xDc	40	0.015xDc	30	0.015xDc	40	0.015xDc	
Stainless Steel Materials										
M	GR8-1 Ferritic \ Martensitic			50	0.013xDc			50	0.013xDc	
	GR8-2 Austenitic			50	0.013xDc			50	0.013xDc	
	GR8-3 Austenitic-ferritic			50	0.013xDc			50	0.013xDc	
	GR8-4 Austenitic-ferritic Heat-resistant			40	0.012xDc			40	0.012xDc	
Cast Iron Materials										
K	GR9-1 Grey cast iron	80	0.023xDc	100	0.023xDc	70	0.023xDc	100	0.023xDc	
	GR9-2 Nodular cast iron	80	0.023xDc	100	0.023xDc	70	0.023xDc	100	0.023xDc	

All cutting data serve for orientation only and should be adapted individually to the technical conditions on location



















1. Please work with good rigidity / high precision facilities and collet chuck.
2. Please choose proper cutting fluid.
3. The cutting data is reference value only. Please adjust it according to your real working conditions.
4. If RPM is lower the reference value, the Feed rate (fz) and RPM should be reduced by the same proportion.
5. If vibration occurs during cutting, please reduce cutting parameter.

Cutting Conditions

	D437FT		D415		D419FT	
	cutting speed Vc (m/min)	feed per tooth fz(mm)	cutting speed Vc (m/min)	feed per tooth fz(mm)	cutting speed Vc (m/min)	feed per tooth fz(mm)
P	Carbon Steel Materials					
	GRI Carbon Steel	100	0.023xDc		80	0.02xDc
	GR2 <24HRC Low-alloyed Steel	100	0.023xDc		80	0.02xDc
	GR3 <30HRC Hi-alloyed Steel	90	0.021xDc		70	0.015xDc
H	Hardened Steel Materials					
	GR4 30-38HRC Hardened Steel	50	0.020xDc		50	0.015xDc
	GR5 38-48HRC Hardened Steel	40	0.015xDc		40	0.01xDc
M	Stainless Steel Materials					
	GR8-1 Ferritic \ Martensitic	50	0.013xDc			
	GR8-2 Austenitic	50	0.013xDc			
	GR8-3 Austenitic-ferritic	50	0.013xDc			
	GR8-4 Austenitic-ferritic Heat-resistant	40	0.012xDc			
K	Cast Iron Materials					
	GR9-1 Grey cast iron	100	0.023xDc		80	0.02xDc
	GR9-2 Nodular cast iron	100	0.023xDc		80	0.02xDc
N	Aluminium Steel Materials					
	GR10-1 Wrought Aluminium alloys			120	0.03xDc	
	GR10-2 Aluminium cast alloys <10%			120	0.02xDc	
	GR10-3 Aluminium cast alloys >10%			120	0.015xDc	
	Copper Steel Materials					
	GR11-1 Pure Copper			80	0.02xDc	
	GR11-2 Brass			80	0.02xDc	
	GR11-2 Bronze			80	0.02xDc	

1. Please work with good rigidity / high precision facilities and collet chuck.
2. Please choose proper cutting fluid.
3. The cutting data is reference value only. Please adjust it according to your real working conditions.
4. If RPM is lower the reference value, the Feed rate [fz] and RPM should be reduced by the same proportion.
5. If vibration occurs during cutting, please reduce cutting parameter.

Reamers

Page	305	306	307	308	309	311
Appearance						
Code No	R300	R301	R302	R303	R308	R309
Carbide	VHM Carbide	VHM Carbide	VHM Carbide	HM Carbide Tipped	VHM Carbide	VHM Carbide
Coating	Uncoated Bright	Uncoated Bright	Uncoated Bright	Uncoated Bright	Uncoated Bright	Uncoated Bright
Helix Angle	 0°	 7°	 7°	 7°	 7°	 7°
No. of Flutes	 Z	 Z	 Z	 Z	 Z	 Z

DIN

313

315



R319

R329

VHM
Carbide

VHM
Carbide

Uncoated
Bright

Uncoated
Bright



R300

Machine Reamers

Designed with left helix and right cutting flutes.
Downward chip evacuation.

Tolerance: Dc
+0.004/+0.008: 0.5-3.0
+0.005/+0.010: 3.0-6.0
+0.006/+0.012: 6.0-10
+0.008/+0.015: 10-18
+0.009/+0.017: 18-30

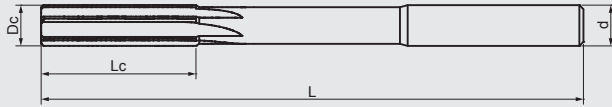

VHM
Carbide

HM
Carbide
Tipped

Uncoated
Bright



Steel
Cast Iron
AL, Copper

Application for reaming different steels below
48HRC, cast iron...and etc.



P
H
K

VHM

P
H
K

HM

Standard Length

Dc H7	Lc mm	L mm	d mm	Z teeth	R300 Bright	R300 Bright
1	6	34	1	4	●	
1.5	8	40	1.5	4	●	
2	11	49	2	4	●	
2.5	14	57	2.5	4	●	
3	15	61	3	4	●	
3.5	18	70	3.5	4	●	
4	19	75	4	4	●	
4.5	21	80	4.5	4	●	
5	23	86	5	6	●	
6	26	93	6	6	●	
7	31	109	7	6	●	
8	33	117	8	6	●	
9	36	125	9	6	●	
10	38	133	10(※10)	6	●	●
11	41	142	10(※11)	6	●	●
12	44	151	10(※12)	6	●	●
13	44	151	10	6		●
14	47	160	12.5	6		●
15	50	162	12.5	6		●
16	52	170	12.5	6		●
18	56	182	14.0	6		●
20	60	195	16.0	6		●

Please refer to page 317 for parameters.

R301

Machine Reamers

Designed with left helix and right cutting flutes.

Downward chip evacuation.

Tolerance: Dc
 +0.004/+0.008: 0.5-3.0
 +0.005/+0.010: 3.0-6.0
 +0.006/+0.012: 6.0-10
 +0.008/+0.015: 10-18
 +0.009/+0.017: 18-30

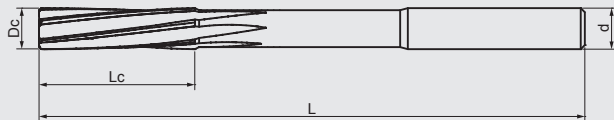
**VHM
Carbide**
**HM
Carbide
Tipped**
**Uncoated
Bright**

**Steel
Cast Iron
AL, Copper**

Application for reaming different steels below
 48HRC, cast iron...and etc.

P
H
K

VHM

P
H
K

HM

Standard Length

Dc H7	Lc mm	L mm	d mm	Z teeth	R301 Bright	R301 Bright
1	6	34	1	4	●	
1.5	8	40	1.5	4	●	
2	11	49	2	4	●	
2.5	14	57	2.5	4	●	
3	15	61	3	4	●	
3.5	18	70	3.5	4	●	
4	19	75	4	4	●	
4.5	21	80	4.5	4	●	
5	23	86	5	6	●	
5.5	26	93	5.5	6	●	
6	26	93	6	6	●	
6.5	28	101	6.5	6	●	
7	31	109	7	6	●	
7.5	31	109	7.5	6	●	
8	33	117	8	6	●	
8.5	33	117	8.5	6	●	
9	36	125	9	6	●	
9.5	36	125	9.5	6	●	
10	38	133	10(※10)	6	●	●
10.5	38	133	10(※10.5)	6	●	●
11	41	142	10(※11)	6	●	●
11.5	41	142	10(※11.5)	6	●	●
12	44	151	10(※12)	6	●	●
12.5	44	151	10	6		●
13	44	151	10	6		●
13.5	47	160	12.5	6		●
14	47	160	12.5	6		●
14.5	50	162	12.5	6		●
15	50	162	12.5	6		●
15.5	52	170	12.5	6		●
16	52	170	12.5	6		●
17	54	175	14	6		●
18	56	182	14	6		●
19	58	189	16	6		●
20	60	195	16	6		●

Please refer to page 317 for parameters.

R302

Machine Reamers

Designed with left helix and right cutting flutes.
Downward chip evacuation.

Tolerance: Dc
+0.004/+0.008: 0.5-3.0
+0.005/+0.010: 3.0-6.0
+0.006/+0.012: 6.0-10
+0.008/+0.015: 10-18
+0.009/+0.017: 18-30

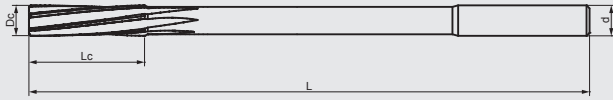

VHM
Carbide

HM
Carbide
Tipped

Uncoated
Bright



Steel
Cast Iron
AL, Copper



Application for reaming different steels below
48HRC, cast iron...and etc.

P
H
K

VHM

P
H
K

HM

Long Length

Dc H7	Lc mm	L mm	d mm	Z teeth	R302 Bright	R302 Bright
3	15	100	3	4	●	
3.5	18	112	3.5	4	●	
4	19	119	4	4	●	
4.5	21	126	4.5	4	●	
5	23	132	5	6	●	
6	26	139	6	6	●	
7	31	156	7	6	●	
8	33	165	8	6	●	
9	36	175	9	6	●	
10	38	184	10	6		●
11	41	195	10	6		●
12	44	205	10	6		●
13	44	205	10	6		●
14	47	214	12.5	6		●
15	50	220	12.5	6		●
16	52	227	12.5	6		●
17	54	235	14	6		●
18	56	241	14	6		●
19	58	247	16	6		●
20	60	254	16	6		●

Please refer to page 317 for parameters.

R303

Machine Reamers

Designed with left helix and right cutting flutes.

Downward chip evacuation.

Tolerance: Dc

+0.004/+0.008: 0.5-3.0

+0.005/+0.010: 3.0-6.0

+0.006/+0.012: 6.0-10

+0.008/+0.015: 10-18

+0.009/+0.017: 18-30

+0.012/+0.021: 30-50

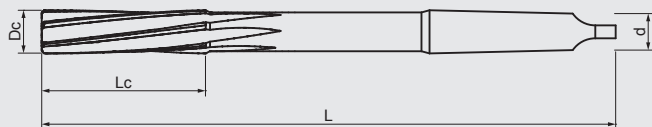

HM
Carbide
Tipped

Uncoated
Bright



Steel
Cast Iron
AL, Copper



Application for reaming different steels below
48HRC, cast iron...and etc.

P

H

K

HM

Standard Length

Dc H7	Lc mm	L mm	d M.T.	Z teeth	R303 Bright		
10	38	168	1	6	●		
11	41	175	1	6	●		
12	44	182	1	6	●		
13	44	182	1	6	●		
14	47	189	1	6	●		
15	50	204	2	6	●		
16	52	210	2	6	●		
17	54	214	2	6	●		
18	56	219	2	6	●		
19	58	223	2	6	●		
20	60	228	2	6	●		
22	64	237	2	6	●		
24	68	268	3	8	●		
25	68	268	3	8	●		
26	70	273	3	8	●		
28	71	277	3	8	●		
30	73	281	3	8	●		
32	77	317	4	8	●		
35	78	321	4	8	●		
36	79	325	4	8	●		
38	81	329	4	8	●		
41	81	325	4	8	●		

Please refer to page 317 for parameters.

R308

Machine Reamers In Steps of 0.1mm

Designed with left helix and right cutting flutes.

Downward chip evacuation.

Tolerance: Dc

+0.004/+0.008: 0.5-3.0

+0.005/+0.010: 3.0-6.0

+0.006/+0.012: 6.0-10

+0.008/+0.015: 10-18

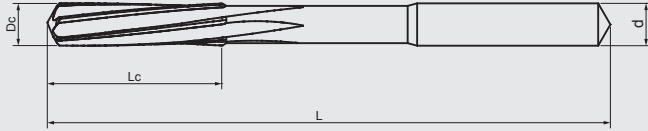
VHM
CarbideUncoated
BrightSteel
Cast Iron
AL, CopperApplication for reaming different steels below
48HRC, cast iron...and etc.

P

H

K

Standard Length

Dc H7	Lc mm	L mm	Z teeth	R308 Bright
1	6	34	4	●
1.1	7	36	4	●
1.2	7	38	4	●
1.3	7	38	4	●
1.4	8	40	4	●
1.5	8	40	4	●
1.6	9	43	4	●
1.7	9	43	4	●
1.8	10	46	4	●
1.9	10	46	4	●
2	11	49	4	●
2.1	11	49	4	●
2.2	12	53	4	●
2.3	12	53	4	●
2.4	14	57	4	●
2.5	14	57	4	●
2.6	14	57	4	●
2.7	15	61	4	●
2.8	15	61	4	●
2.9	15	61	4	●
3	15	61	4	●
3.1	16	65	4	●
3.2	16	65	4	●
3.3	16	65	4	●
3.4	18	70	4	●
3.5	18	70	4	●
3.6	18	70	4	●
3.7	18	70	4	●
3.8	19	75	4	●
3.9	19	75	4	●
4	19	75	4	●
4.1	19	75	4	●
4.2	19	75	4	●
4.3	21	80	4	●
4.4	21	80	4	●
4.5	21	80	4	●
4.6	21	80	6	●
4.7	21	80	6	●
4.8	23	86	6	●
4.9	23	86	6	●

Machine Reamers In Steps of 0.1mm

Dc H7	Lc mm	L mm	Z teeth	R308 Bright		
5	23	86	6	●		
5.1	23	86	6	●		
5.2	23	86	6	●		
5.3	23	86	6	●		
5.4	26	93	6	●		
5.5	26	93	6	●		
5.6	26	93	6	●		
5.7	26	93	6	●		
5.8	26	93	6	●		
5.9	26	93	6	●		
6	26	93	6	●		
6.1	28	101	6	●		
6.2	28	101	6	●		
6.3	28	101	6	●		
6.4	28	101	6	●		
6.5	28	101	6	●		
6.6	28	101	6	●		
6.7	31	101	6	●		
6.8	31	109	6	●		
6.9	31	109	6	●		
7	31	109	6	●		
7.1	31	109	6	●		
7.2	31	109	6	●		
7.3	31	109	6	●		
7.4	31	109	6	●		
7.5	31	109	6	●		
7.6	33	117	6	●		
7.7	33	117	6	●		
7.8	33	117	6	●		
7.9	33	117	6	●		
8	33	117	6	●		
8.1	33	117	6	●		
8.2	33	117	6	●		
8.3	33	117	6	●		
8.4	33	117	6	●		
8.5	33	117	6	●		
8.6	36	125	6	●		
8.7	36	125	6	●		
8.8	36	125	6	●		
8.9	36	125	6	●		
9	36	125	6	●		
9.1	36	125	6	●		
9.2	36	125	6	●		
9.3	36	125	6	●		
9.4	36	125	6	●		
9.5	36	125	6	●		
9.6	38	133	6	●		
9.7	38	133	6	●		
9.8	38	133	6	●		
9.9	38	133	6	●		
10	38	133	6	●		
10.1	38	133	6	●		
10.2	38	133	6	●		
10.3	38	133	6	●		
10.4	38	133	6	●		
10.5	38	133	6	●		
10.6	38	133	6	●		
10.7	41	142	6	●		
10.8	41	142	6	●		
10.9	41	142	6	●		
11	41	142	6	●		
11.1	41	142	6	●		
11.2	41	142	6	●		
11.3	41	142	6	●		
11.4	41	142	6	●		
11.5	41	142	6	●		
11.6	41	142	6	●		
11.7	41	142	6	●		
11.8	41	142	6	●		
11.9	41	151	6	●		
12	41	151	6	●		

Please refer to page 318 for parameters.

R309

NC Machine Reamers

Designed with left helix and right cutting flutes.
Downward chip evacuation.
Accuracy tolerance: 0/+0.004mm.

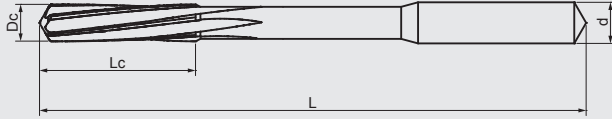

**VHM
Carbide**

**Uncoated
Bright**



**Steel
<56HRC**



Application for reaming different steels below
56HRC, cast iron...and etc.

P
H
K

Standard Length

Dc +0.004 -0	Lc mm	L mm	d mm	Z teeth	R309 Bright
2.95	15	61	3	4	●
2.96	15	61	3	4	●
2.97	15	61	3	4	●
2.98	15	61	3	4	●
2.99	15	61	3	4	●
3	15	61	3	4	●
3.01	15	61	3	4	●
3.02	15	61	3	4	●
3.03	15	61	3	4	●
3.04	15	61	3	4	●
3.05	15	61	3	4	●
3.95	19	75	4	4	●
3.96	19	75	4	4	●
3.97	19	75	4	4	●
3.98	19	75	4	4	●
3.99	19	75	4	4	●
4	19	75	4	4	●
4.01	19	75	4	4	●
4.02	19	75	4	4	●
4.03	19	75	4	4	●
4.04	19	75	4	4	●
4.05	19	75	4	4	●
4.95	23	86	5	6	●
4.96	23	86	5	6	●
4.97	23	86	5	6	●
4.98	23	86	5	6	●
4.99	23	86	5	6	●
5	23	86	5	6	●
5.01	23	86	5	6	●
5.02	23	86	5	6	●
5.03	23	86	5	6	●
5.04	23	86	5	6	●
5.05	23	86	5	6	●
5.95	26	93	6	6	●
5.96	26	93	6	6	●
5.97	26	93	6	6	●
5.98	26	93	6	6	●
5.99	26	93	6	6	●

NC Machine Reamers

Dc $+0.004$ -0	Lc mm	L mm	d mm	Z teeth	R309 Bright		
6	26	93	6	6	●		
6.01	26	93	6	6	●		
6.02	26	93	6	6	●		
6.03	26	93	6	6	●		
6.04	26	93	6	6	●		
6.05	26	93	6	6	●		
6.95	31	109	7	6	●		
6.96	31	109	7	6	●		
6.97	31	109	7	6	●		
6.98	31	109	7	6	●		
6.99	31	109	7	6	●		
7	31	109	7	6	●		
7.01	31	109	7	6	●		
7.02	31	109	7	6	●		
7.03	31	109	7	6	●		
7.04	31	109	7	6	●		
7.05	31	109	7	6	●		
7.95	33	117	8	6	●		
7.96	33	117	8	6	●		
7.97	33	117	8	6	●		
7.98	33	117	8	6	●		
7.99	33	117	8	6	●		
8	33	117	8	6	●		
8.01	33	117	8	6	●		
8.02	33	117	8	6	●		
8.03	33	117	8	6	●		
8.04	33	117	8	6	●		
8.05	33	117	8	6	●		
8.95	36	125	9	6	●		
8.96	36	125	9	6	●		
8.97	36	125	9	6	●		
8.98	36	125	9	6	●		
8.99	36	125	9	6	●		
9	36	125	9	6	●		
9.01	36	125	9	6	●		
9.02	36	125	9	6	●		
9.03	36	125	9	6	●		
9.04	36	125	9	6	●		
9.05	36	125	9	6	●		
9.95	38	133	10	6	●		
9.96	38	133	10	6	●		
9.97	38	133	10	6	●		
9.98	38	133	10	6	●		
9.99	38	133	10	6	●		
10	38	133	10	6	●		
10.01	38	133	10	6	●		
10.02	38	133	10	6	●		
10.03	38	133	10	6	●		
10.04	38	133	10	6	●		
10.05	38	133	10	6	●		
11.95	44	151	12	6	●		
11.96	44	151	12	6	●		
11.97	44	151	12	6	●		
11.98	44	151	12	6	●		
11.99	44	151	12	6	●		
12	44	151	12	6	●		
12.01	44	151	12	6	●		
12.02	44	151	12	6	●		
12.03	44	151	12	6	●		
12.04	44	151	12	6	●		
12.05	44	151	12	6	●		

Please refer to page 318 for parameters.

R319

NC Machine Reamers In Steps of 0.01mm

Designed with left helix and right cutting flutes.
Downward chip evacuation.
Accuracy tolerance: 0/+0.004mm.

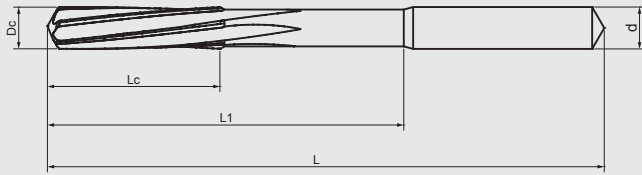

VHM Carbide **Uncoated Bright** **7°** **Z** **Steel <56HRC**



Application for reaming different steels below 56HRC, cast iron...and etc.

P
H
K

Standard Length

Dc $+0.004$ -0	Lc mm	L1 mm	L mm	d h5	Z teeth	R319 Bright		
0.98~0.99	6	18	50	4	3	●		
1.00	6	18	50	4	3	●		
1.01~1.02	6	18	50	4	3	●		
1.03~1.10	9	18	50	4	3	●		
1.11~1.19	9	18	50	4	3	●		
1.20	9	18	50	4	3	●		
1.21~1.30	9	18	50	4	3	●		
1.31~1.39	9	18	50	4	3	●		
1.40	9	18	50	4	3	●		
1.41~1.42	9	18	50	4	3	●		
1.43~1.49	9	18	50	4	3	●		
1.50	9	18	50	4	3	●		
1.51~1.53	10	18	50	4	3	●		
1.54~1.59	10	18	50	4	3	●		
1.60	10	18	50	4	3	●		
1.61~1.70	10	18	50	4	3	●		
1.71~1.79	10	19	50	4	4	●		
1.80	11	19	50	4	4	●		
1.81~1.90	11	19	50	4	4	●		
1.91~1.99	12	19	50	4	4	●		
2.00	12	19	50	4	4	●		
2.01~2.03	12	19	50	4	4	●		
2.04~2.12	12	19	50	4	4	●		
2.13~2.19	12	19	50	4	4	●		
2.20	12	19	50	4	4	●		
2.21~2.36	12	19	50	4	4	●		
2.37~2.49	16	29	60	4	4	●		
2.50	16	29	60	4	4	●		
2.51~2.65	16	29	60	4	4	●		
2.66~2.79	17	33	65	4	6	●		
2.80	17	33	65	4	6	●		
2.81~2.90	17	33	65	4	6	●		
2.91~2.99	17	33	65	4	6	●		
3.00	17	33	65	4	6	●		
3.01~3.03	17	33	65	4	6	●		
3.04~3.19	18	33	65	4	6	●		
3.20	18	33	65	4	6	●		
3.21~3.35	18	33	65	4	6	●		
3.36~3.49	18	43	75	4	6	●		
3.50	18	43	75	4	6	●		
3.51~3.60	18	43	75	4	6	●		
3.61~3.75	18	43	75	4	6	●		

R319

NC Machine Reamers In Steps of 0.01mm

Dc +0.004 0	Lc mm	L1 mm	L mm	d h5	Z teeth	R319 Bright		
3.76~3.90	19	43	75	4	6	●		
3.91~3.99	19	43	75	4	6	●		
4.00	19	43	75	4	6	●		
4.01~4.09	19	43	75	4	6	●		
4.10~4.25	19	43	75	4	6	●		
4.26~4.49	21	49	80	6	6	●		
4.50	21	49	80	6	6	●		
4.51~4.60	21	49	80	6	6	●		
4.61~4.75	21	49	80	6	6	●		
4.76~4.90	23	52	93	6	6	●		
4.91~4.99	23	52	93	6	6	●		
5.00	23	52	93	6	6	●		
5.01~5.10	23	52	93	6	6	●		
5.11~5.30	23	52	93	6	6	●		
5.31~5.40	26	53	93	6	6	●		
5.41~5.49	26	53	93	6	6	●		
5.50	26	53	93	6	6	●		
5.51~5.60	26	53	93	6	6	●		
5.61~5.80	26	53	93	6	6	●		
5.81~5.90	26	53	93	6	6	●		
5.91~5.99	26	53	93	6	6	●		
6.00	26	53	93	6	6	●		
6.01~6.03	26	53	93	6	6	●		
6.04~6.30	28	61	101	8	6	●		
6.31~6.49	28	61	101	8	6	●		
6.50	28	61	101	8	6	●		
6.51~6.70	28	61	101	8	6	●		
6.71~6.80	31	68	109	8	6	●		
6.81~6.99	31	68	109	8	6	●		
7.00	31	68	109	8	6	●		
7.01~7.10	31	68	109	8	6	●		
7.11~7.30	31	68	109	8	6	●		
7.31~7.49	31	68	109	8	6	●		
7.50	31	68	109	8	6	●		
7.51~7.60	33	77	117	8	6	●		
7.61~7.80	33	77	117	8	6	●		
7.81~7.90	33	77	117	8	6	●		
7.91~7.99	33	77	117	8	6	●		
8.00	33	77	117	8	6	●		
8.01~8.09	33	77	117	8	6	●		
8.10~8.30	33	77	117	8	6	●		
8.31~8.49	33	77	117	8	6	●		
8.50	33	77	117	8	6	●		
8.51~8.60	36	80	125	10	6	●		
8.61~8.80	36	80	125	10	6	●		
8.81~8.99	36	80	125	10	6	●		
9.00	36	80	125	10	6	●		
9.01~9.10	36	80	125	10	6	●		
9.11~9.30	36	80	125	10	6	●		
9.31~9.49	36	80	125	10	6	●		
9.50	36	80	125	10	6	●		
9.51~9.69	38	88	133	10	6	●		
9.70~9.85	38	88	133	10	6	●		
9.86~9.90	38	88	133	10	6	●		
9.91~9.99	38	88	133	10	6	●		
10.00	38	88	133	10	6	●		
10.01~10.05	38	88	133	10	6	●		
10.06~10.20	38	88	133	10	6	●		
10.21~10.49	38	88	133	10	6	●		
10.50	38	88	133	10	6	●		
10.51~10.60	38	88	133	10	6	●		
10.61~10.79	41	97	142	10	6	●		
10.80~10.99	41	97	142	10	6	●		
11.00	41	97	142	10	6	●		
11.01~11.06	41	97	142	10	6	●		
11.07~11.39	41	97	142	10	6	●		
11.40~11.49	41	97	142	10	6	●		
11.50	41	97	142	10	6	●		
11.51~11.80	41	97	142	10	6	●		
11.81~11.90	44	100	151	12	6	●		
11.91~11.99	44	100	151	12	6	●		
12.00	44	100	151	12	6	●		
12.01~12.05	44	100	151	12	6	●		

Please refer to page 318 for parameters.

R329

NC Machine Reamers Right Hand Helix (End Cutting)

Designed with right helix and right cutting flutes.
Upward chip evacuation.
Accuracy tolerance: $0/+0.004\text{mm}$.

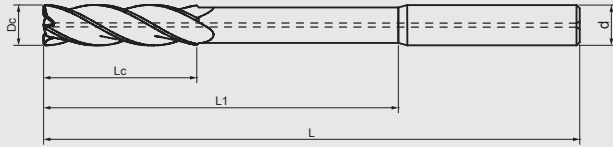

VHM
Carbide

Uncoated
Bright



Steel
Cast Iron
AL, Copper



Application for reaming different steels below
56HRC, cast iron...and etc.
The Reamers with internal coolant for stop holes
The bottom can be perfectly processed.

P
H
K

Standard Length





Dc $+0.004$ -0	Lc mm	L1 mm	L mm	d h5	Z teeth	R329 Bright		
2.95	15	33	61	3	4	●		
2.96	15	33	61	3	4	●		
2.97	15	33	61	3	4	●		
2.98	15	33	61	3	4	●		
2.99	15	33	61	3	4	●		
3	15	33	61	3	4	●		
3.01	15	33	61	3	4	●		
3.02	15	33	61	3	4	●		
3.03	15	33	61	3	4	●		
3.04	15	33	61	3	4	●		
3.05	15	33	61	3	4	●		
3.95	19	43	75	4	4	●		
3.96	19	43	75	4	4	●		
3.97	19	43	75	4	4	●		
3.98	19	43	75	4	4	●		
3.99	19	43	75	4	4	●		
4	19	43	75	4	4	●		
4.01	19	43	75	4	4	●		
4.02	19	43	75	4	4	●		
4.03	19	43	75	4	4	●		
4.04	19	43	75	4	4	●		
4.05	19	43	75	4	4	●		
4.95	23	52	86	5	4	●		
4.96	23	52	86	5	4	●		
4.97	23	52	86	5	4	●		
4.98	23	52	86	5	4	●		
4.99	23	52	86	5	4	●		
5	23	52	86	5	4	●		
5.01	23	52	86	5	4	●		
5.02	23	52	86	5	4	●		
5.03	23	52	86	5	4	●		
5.04	23	52	86	5	4	●		
5.05	23	52	86	5	4	●		
5.95	26	52	93	6	4	●		
5.96	26	52	93	6	4	●		
5.97	26	52	93	6	4	●		

NC Machine Reamers Right Hand Helix (End Cutting)

Dc <small>+0.004 -0</small>	Lc mm	L1 mm	L mm	d h5	Z teeth	R329 Bright		
5.98	26	52	93	6	4	●		
5.99	26	52	93	6	4	●		
6	26	52	93	6	4	●		
6.01	26	52	93	6	4	●		
6.02	26	52	93	6	4	●		
6.03	26	52	93	6	4	●		
6.04	26	52	93	6	4	●		
6.05	26	52	93	6	4	●		
6.95	31	68	109	8	4	●		
6.96	31	68	109	8	4	●		
6.97	31	68	109	8	4	●		
6.98	31	68	109	8	4	●		
6.99	31	68	109	8	4	●		
7	31	68	109	8	4	●		
7.01	31	68	109	8	4	●		
7.02	31	68	109	8	4	●		
7.03	31	68	109	8	4	●		
7.04	31	68	109	8	4	●		
7.05	31	68	109	8	4	●		
7.95	33	77	117	8	4	●		
7.96	33	77	117	8	4	●		
7.97	33	77	117	8	4	●		
7.98	33	77	117	8	4	●		
7.99	33	77	117	8	4	●		
8	33	77	117	8	4	●		
8.01	33	77	117	8	4	●		
8.02	33	77	117	8	4	●		
8.03	33	77	117	8	4	●		
8.04	33	77	117	8	4	●		
8.05	33	77	117	8	4	●		
8.95	36	80	125	10	4	●		
8.96	36	80	125	10	4	●		
8.97	36	80	125	10	4	●		
8.98	36	80	125	10	4	●		
8.99	36	80	125	10	4	●		
9	36	80	125	10	4	●		
9.01	36	80	125	10	4	●		
9.02	36	80	125	10	4	●		
9.03	36	80	125	10	4	●		
9.04	36	80	125	10	4	●		
9.05	36	80	125	10	4	●		
9.95	38	88	133	10	4	●		
9.96	38	88	133	10	4	●		
9.97	38	88	133	10	4	●		
9.98	38	88	133	10	4	●		
9.99	38	88	133	10	4	●		
10	38	88	133	10	4	●		
10.01	38	88	133	10	4	●		
10.02	38	88	133	10	4	●		
10.03	38	88	133	10	4	●		
10.04	38	88	133	10	4	●		
10.05	38	88	133	10	4	●		
11.95	44	100	151	12	4	●		
11.96	44	100	151	12	4	●		
11.97	44	100	151	12	4	●		
11.98	44	100	151	12	4	●		
11.99	44	100	151	12	4	●		
12	44	100	151	12	4	●		
12.01	44	100	151	12	4	●		
12.02	44	100	151	12	4	●		
12.03	44	100	151	12	4	●		
12.04	44	100	151	12	4	●		
12.05	44	100	151	12	4	●		

Please refer to page 318 for parameters.



Cutting Conditions

	R300		R301		R302		R303		R300 R301 R302 R303	
									cutting speed Vc (m/min)	feed per tooth fz(mm)
Carbon Steel Materials										
P	GR1 Carbon Steel	15	0.008xDc	15	0.008xDc	15	0.008xDc	15	0.007xDc	
	GR2 <24HRC Low-alloyed Steel	15	0.008xDc	15	0.008xDc	15	0.008xDc	15	0.007xDc	
	GR3 <30HRC Hi-alloyed Steel	12	0.006xDc	12	0.006xDc	12	0.006xDc	12	0.006xDc	
Hardened Steel Materials										
H	GR4 30-38HRC Hardened Steel	8	0.005xDc	8	0.005xDc	8	0.005xDc	8	0.005xDc	
	GR5 38-48HRC Hardened Steel	5	0.003xDc	5	0.003xDc	5	0.003xDc	5	0.003xDc	
Stainless Steel Materials										
M	GR8-1 Ferritic \ Martensitic	12	0.006xDc	12	0.006xDc	12	0.006xDc	12	0.006xDc	
	GR8-2 Austenitic	12	0.006xDc	12	0.006xDc	12	0.006xDc	12	0.006xDc	
	GR8-3 Austenitic-ferritic	12	0.006xDc	12	0.006xDc	12	0.006xDc	12	0.006xDc	
	GR8-4 Austenitic-ferritic Heat-resistant	8	0.004xDc	8	0.004xDc	8	0.004xDc	8	0.004xDc	
Cast Iron Materials										
K	GR9-1 Grey cast iron	15	0.006xDc	15	0.006xDc	15	0.006xDc	15	0.006xDc	
	GR9-2 Nodular cast iron	15	0.006xDc	15	0.006xDc	15	0.006xDc	15	0.006xDc	
Aluminium Steel Materials										
N	GR10-1 Wrought Aluminium alloys	20	0.006xDc	20	0.006xDc	20	0.006xDc	20	0.006xDc	
	GR10-2 Aluminium cast alloys <10%	20	0.006xDc	20	0.006xDc	20	0.006xDc	20	0.006xDc	
	GR10-3 Aluminium cast alloys >10%	20	0.006xDc	20	0.006xDc	20	0.006xDc	20	0.006xDc	
Copper Steel Materials										
N	GR11-1 Pure Copper	15	0.006xDc	15	0.006xDc	15	0.006xDc	15	0.006xDc	
	GR11-2 Brass	15	0.006xDc	15	0.006xDc	15	0.006xDc	15	0.006xDc	
	GR11-2 Bronze	15	0.006xDc	15	0.006xDc	15	0.006xDc	15	0.006xDc	

All cutting data serve for orientation only and should be adapted individually to the technical conditions on location

1. Please work with good rigidity / high precision facilities and collet chuck.
2. Please choose proper cutting fluid.
3. The cutting data is reference value only. Please adjust it according to your real working conditions.
4. If RPM is lower the reference value, the Feed rate (fz) and RPM should be reduced by the same proportion.
5. If vibration occurs during cutting, please reduce cutting parameter.

Cutting Conditions

	R308 / R309	R319		R329			
		cutting speed Vc (m/min)	feed per tooth fz(mm)	cutting speed Vc (m/min)	feed per tooth fz(mm)	cutting speed Vc (m/min)	feed per tooth fz(mm)
R308 R309 R319 R329							
	Carbon Steel Materials						
	P	GRI Carbon Steel	15	0.008xDc	15	0.008xDc	15
	GR2 <24HRC Low-alloyed Steel	15	0.008xDc	15	0.008xDc	15	0.008xDc
	GR3 <30HRC Hi-alloyed Steel	12	0.006xDc	12	0.006xDc	12	0.006xDc
	Hardened Steel Materials						
H	GR4 30-38HRC Hardened Steel	8	0.005xDc	8	0.005xDc	8	0.005xDc
	GR5 38-48HRC Hardened Steel	5	0.003xDc	5	0.003xDc	5	0.003xDc
	Stainless Steel Materials						
M	GR8-1 Ferritic \ Martensitic	12	0.006xDc	12	0.006xDc	12	0.006xDc
	GR8-2 Austenitic	12	0.006xDc	12	0.006xDc	12	0.006xDc
	GR8-3 Austenitic-ferritic	12	0.006xDc	12	0.006xDc	12	0.006xDc
	GR8-4 Austenitic-ferritic Heat-resistant	8	0.004xDc	8	0.004xDc	8	0.004xDc
	Cast Iron Materials						
K	GR9-1 Grey cast iron	15	0.006xDc	15	0.009xDc	15	0.009xDc
	GR9-2 Nodular cast iron	15	0.006xDc	15	0.009xDc	15	0.009xDc
	Aluminium Steel Materials						
	GR10-1 Wrought Aluminium alloys	20	0.006xDc	20	0.006xDc	20	0.006xDc
	GR10-2 Aluminium cast alloys <10%	20	0.006xDc	20	0.006xDc	20	0.006xDc
	GR10-3 Aluminium cast alloys >10%	20	0.006xDc	20	0.006xDc	20	0.006xDc
N	Copper Steel Materials						
	GR11-1 Pure Copper	15	0.006xDc	15	0.006xDc	15	0.006xDc
	GR11-2 Brass	15	0.006xDc	15	0.006xDc	15	0.006xDc
	GR11-2 Bronze	15	0.006xDc	15	0.006xDc	15	0.006xDc

All cutting data serve for orientation only and should be adapted individually to the technical conditions on location

1. Please work with good rigidity / high precision facilities and collet chuck.
2. Please choose proper cutting fluid.
3. The cutting data is reference value only. Please adjust it according to your real working conditions.
4. If RPM is lower the reference value, the Feed rate (fz) and RPM should be reduced by the same proportion.
5. If vibration occurs during cutting, please reduce cutting parameter.

S445HX Page. 335

Easy Cut End Mills

Three variable helix geometry, three unequal flutes.

With high chip removal rate, and sharp cutting edge, especially has outstanding performance in Stainless Steel.

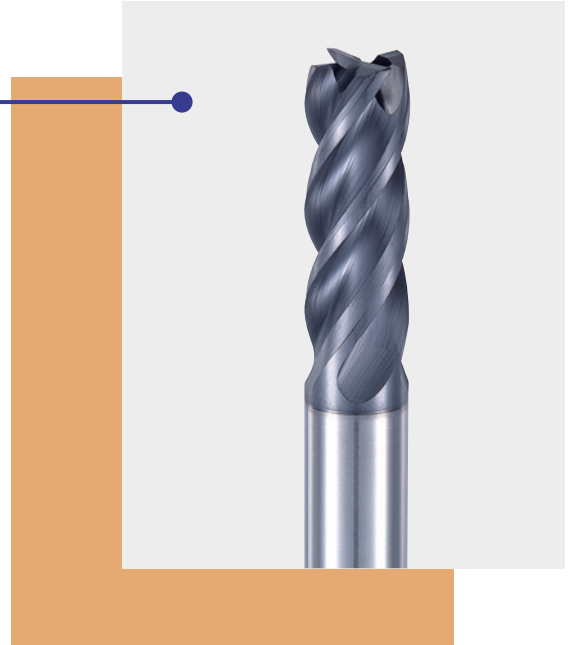

E141-2HX Page. 337

Multipurpose End Mills

Unique tool design can minimize chatter for smoother machining.

Application for Steel, Cast Iron, Stainless Steels, High Temp Alloys and also can be used in various Metal materials.

E143-2 Page. 342

End Mills For Aluminium

Designed for maximum metal removal rates, superior surface finishes and better anti-vibration rate.

Use for Aluminium which from roughing to finishing operations with one tool.

NEW !

E100HX

Page. 357



Double Angle Cutter
4 Flute Chamfering
30°&60°&90°&120°

Use for high performance applications and it is extremely heat resistant and used on Steel, Stainless Steels, Cast Iron, Non-ferrous metals and other tough to machine materials.



E107X

Page. 355

E109X







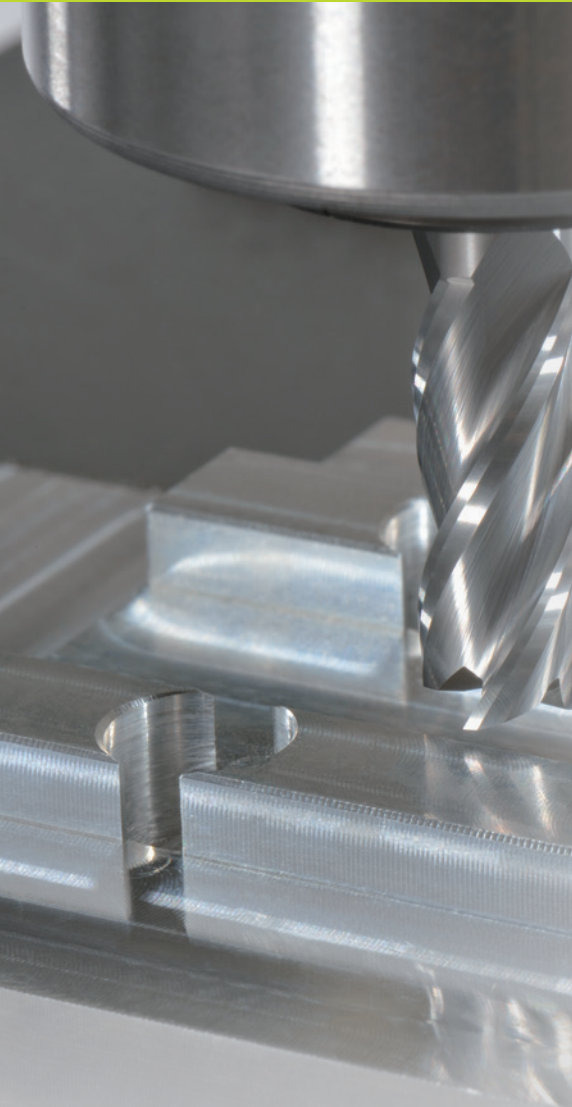

Page. 356

Chamfer Mills
2 & 4 Flute Chamfering 90°

Application for drilling, chamfering, countersink, spotting, and profile milling.

End Mills · Drills · Reamers



Page	323	323	324	324	325	325
Apperance						
Code No	E172	E174	E182 E185 E187	E184 E186 E188	B212	B214
Carbide	MG Carbide	MG Carbide	MG Carbide	MG Carbide	MG Carbide	MG Carbide
Coating	Uncoated Bright	Uncoated Bright	Uncoated Bright	Uncoated Bright	Uncoated Bright	Uncoated Bright
Helix Angle	 30°	 30°	 30°	 30°	 30°	 30°
No.of Flutes	 Z=2	 Z=4	 Z=2	 Z=4	 Z=2	 Z=4

ANSI

326	326	327	328	328	329	331
						
B280 B282	B281 B284	E133	E135	E136 E137	D453	R391
MG Carbide	MG Carbide	MG Carbide	MG Carbide	MG Carbide	MG Carbide	MG Carbide
Uncoated Bright	Uncoated Bright	Uncoated Bright	Uncoated Bright	Uncoated Bright	Uncoated Bright	Uncoated Bright
 30°	 30°	 45°	 45°	 45°	 30°	 0°
 Z=2	 Z=4	 Z=3	 Z=3	 Z=3	 Z=2	 Z

Square End Mills

2&4 Flute Center Cutting

MG
 Carbide

Bright
 TiAlN

30°



H

710°

90°

Code No: E172-DC / E174-DC

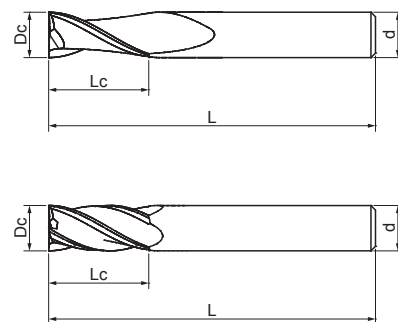

Work Material

P	H	M	K	N	S
●	○	○	○	○	○

P	Steel
M	Stainless Steel
K	Cast Iron
N	Aluminium
N	Copper
N	Plastics
S	Titanium
S	Nickel

Tolerance: DC

All Sizes: +0/-0.03mm

Feature of product:

Center Cutting tools are used in a variety of applications including plunging, drilling or ramping.....

TiAlN is one of abrasive resistant coatings. It is commonly used for machining aircraft and aerospace material, Nickel Alloys, Stainless Steels, Titanium, Cast Iron and Steel.

Standard Length

Dc 0 -0.03	Lc mm	L mm	d h6	Bright E172	TiAlN E172F	Bright E174	TiAlN E174F
0.2	0.5	38	3	●	●		
0.3	0.8	38	3	●	●		
0.4	1	38	3	●	●		
0.5	1.2	38	3	●	●		
0.6	1.5	38	3	●	●		
0.7	1.8	38	3	●	●		
0.8	2	38	3	●	●		
0.9	2.5	38	3	●	●		
1	3	38	3	●	●	●	●
1.5	5	38	3	●	●	●	●
2	6	38	3	●	●	●	●
2.5	7	38	3	●	●	●	●
3	9	38	3	●	●	●	●
3.5	12	50	4	●	●	●	●
4	14	50	4	●	●	●	●
4.5	14	50	5	●	●	●	●
5	16	50	5	●	●	●	●
5.5	16	50	6	●	●	●	●
6	20	63	6	●	●	●	●
6.5	20	63	8	●	●	●	●
7	20	63	8	●	●	●	●
7.5	20	63	8	●	●	●	●
8	20	63	8	●	●	●	●
8.5	22	72	10	●	●	●	●
9	22	72	10	●	●	●	●
9.5	22	72	10	●	●	●	●
10	22	72	10	●	●	●	●
11	26	75	12	●	●	●	●
12	26	75	12	●	●	●	●
13	32	89	14	●	●	●	●
14	32	89	14	●	●	●	●
15	32	89	16	●	●	●	●
16	32	89	16	●	●	●	●
17	38	100	18	●	●	●	●
18	38	100	18	●	●	●	●
20	38	100	20	●	●	●	●

Square End Mills

2&4 Flute Center Cutting

MG
 Carbide

Bright
 TiAlN

Code No: E182-DC / E184-DC
 Code No: E185-DC / E186-DC
 Code No: E187-DC / E188-DC

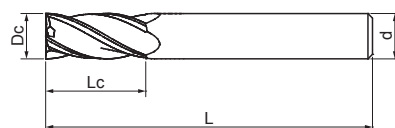
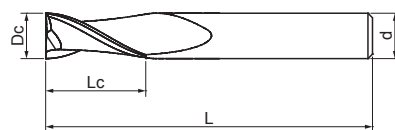

Work Material

P	H	M	K	N	S
●	○	○	○	○	○

P	Steel
----------	-------

M	Stainless Steel
----------	-----------------

K	Cast Iron
----------	-----------

N	Aluminium
----------	-----------

N	Copper
----------	--------

N	Plastics
----------	----------

S	Titanium
----------	----------

S	Nickel
----------	--------

Tolerance: DC

All Sizes: +0/-0.03mm

Feature of product:

Center Cutting tools are used in a variety of applications including plunging, drilling or ramping.....

TiAlN is one of abrasive resistant coatings. It is commonly used for machining aircraft and aerospace material, Nickel Alloys, Stainless Steels, Titanium, Cast Iron and Steel.

Long Length

Dc 0 -0.03	Lc mm	L mm	d h6	Bright E182	TiAlN E182F	Bright E184	TiAlN E184F
3	20	57	3	●	●	●	●
4	20	57	4	●	●	●	●
5	25	63	5	●	●	●	●
6	28	75	6	●	●	●	●
7	30	75	8	●	●	●	●
8	30	75	8	●	●	●	●
9	32	75	10	●	●	●	●
10	32	75	10	●	●	●	●
12	50	100	12	●	●	●	●
14	57	127	14	●	●	●	●
16	57	127	16	●	●	●	●
20	57	127	20	●	●	●	●

Extra Long Length

Dc 0 -0.03	Lc mm	L mm	d h6	Bright E185	TiAlN E185F	Bright E186	TiAlN E186F
3	25	75	3	●	●	●	●
4	28	75	4	●	●	●	●
5	32	75	5	●	●	●	●
6	38	100	6	●	●	●	●
8	42	100	8	●	●	●	●
10	45	100	10	●	●	●	●
12	75	150	12	●	●	●	●
14	80	150	14	●	●	●	●
16	80	150	16	●	●	●	●
20	80	150	20	●	●	●	●

Extra Long Length

Dc 0 -0.03	Lc mm	L mm	d h6	Bright E187	TiAlN E187F	Bright E188	TiAlN E188F
5	45	100	6	●	●	●	●
6	50	100	6	●	●	●	●
8	75	150	8	●	●	●	●
10	75	150	10	●	●	●	●
12	75	200	12	●	●	●	●
16	80	200	16	●	●	●	●
20	80	200	20	●	●	●	●

Ball Nose End Mills

2&4 Flute Center Cutting

MG
 Carbide

Bright
 TiAlN

Code No: B212-DC / B214-DC

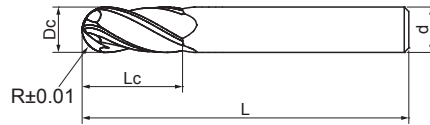
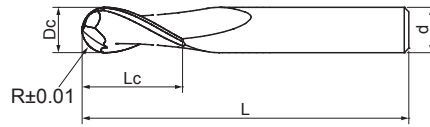

Work Material

P	H	M	K	N	S
●	○	○	○	○	○

P	Steel
----------	-------

M	Stainless Steel
----------	-----------------

K	Cast Iron
----------	-----------

N	Aluminium
----------	-----------

N	Copper
----------	--------

N	Plastics
----------	----------

S	Titanium
----------	----------

S	Nickel
----------	--------

Tolerance: DC

All Sizes: +0/-0.03mm

Feature of product:

Provide better rigidity and heat resistant.

Use for high speed applications on cast iron, nonferrous materials, plastics and other tough-to-machine materials.

TiAlN is one of the abrasive resistant coatings. It is commonly used for machining aircraft and aerospace material, Nickel Alloys, Stainless Steels, Titanium, Cast Iron and Steel.

Standard Length

Dc 0 -0.03	R ±0.01	Lc mm	L mm	d h6	Bright B212	TiAlN B212F	Bright B214	TiAlN B214F
0.2	0.1R	0.4	38	3	●	●		
0.3	0.15R	0.6	38	3	●	●		
0.4	0.2R	0.8	38	3	●	●		
0.5	0.25R	1	38	3	●	●		
0.6	0.3R	1.2	38	3	●	●		
0.7	0.35R	1.4	38	3	●	●		
0.8	0.4R	1.6	38	3	●	●		
0.9	0.45R	2	38	3	●	●		
1	0.5R	3	38	3	●	●	●	●
1.5	0.75R	5	38	3	●	●	●	●
2	1R	6	38	3	●	●	●	●
2.5	1.25R	7	38	3	●	●	●	●
3	1.5R	9	38	3	●	●	●	●
3.5	1.75R	12	50	4	●	●	●	●
4	2R	14	50	4	●	●	●	●
4.5	2.25R	16	50	5	●	●	●	●
5	2.5R	16	50	5	●	●	●	●
5.5	2.75R	16	50	6	●	●	●	●
6	3R	20	63	6	●	●	●	●
6.5	3.25R	20	63	8	●	●	●	●
7	3.5R	20	63	8	●	●	●	●
7.5	3.75R	20	63	8	●	●	●	●
8	4R	20	63	8	●	●	●	●
8.5	4.25R	22	72	10	●	●	●	●
9	4.5R	22	72	10	●	●	●	●
9.5	4.75R	22	72	10	●	●	●	●
10	5R	22	72	10	●	●	●	●
11	5.5R	26	75	12	●	●	●	●
12	6R	26	75	12	●	●	●	●
13	6.5R	32	89	14	●	●	●	●
14	7R	32	89	14	●	●	●	●
15	7.5R	32	89	16	●	●	●	●
16	8R	32	89	16	●	●	●	●
17	8.5R	38	100	18	●	●	●	●
18	9R	38	100	18	●	●	●	●
20	10R	38	100	20	●	●	●	●

Ball Nose End Mills

2&4 Flute Center Cutting

MG
 Carbide

Bright
 TiAlN

Code No: B280-DC / B281-DC

Code No: B282-DC / B284-DC

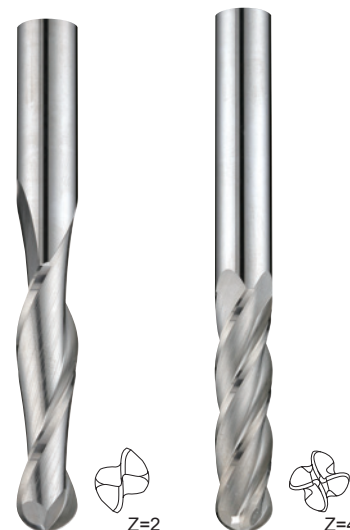
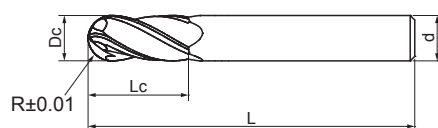
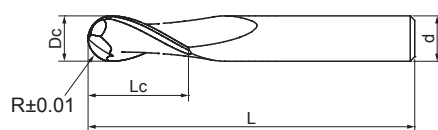

Work Material

P	H	M	K	N	S
●	○	○	○	○	○

P	Steel
----------	-------

M	Stainless Steel
----------	-----------------

K	Cast Iron
----------	-----------

N	Aluminium
----------	-----------

N	Copper
----------	--------

N	Plastics
----------	----------

S	Titanium
----------	----------

S	Nickel
----------	--------

Tolerance: DC

All Sizes: +0/-0.03mm

Feature of product:

Provide better rigidity and heat resistant.

Use for high speed applications on cast iron, nonferrous materials, plastics and other tough-to-machine materials.

TiAlN is one of the abrasive resistant coatings. It is commonly used for machining aircraft and aerospace material, Nickel Alloys, Stainless Steels, Titanium, Cast Iron and Steel.

Long Length

Dc 0 -0.03	R ±0.01	Lc mm	L mm	d h6	Bright B280	TiAlN B280F	Bright B281	TiAlN B281F
3	1.5R	20	57	3	●	●	●	●
4	2R	20	57	4	●	●	●	●
5	2.5R	25	63	5	●	●	●	●
6	3R	28	75	6	●	●	●	●
7	3.5R	30	75	8	●	●	●	●
8	4R	30	75	8	●	●	●	●
9	4.5R	32	75	10	●	●	●	●
10	5R	32	75	10	●	●	●	●
12	6R	50	100	12	●	●	●	●
14	7R	57	127	14	●	●	●	●
16	8R	57	127	16	●	●	●	●
20	10R	57	127	20	●	●	●	●

Extra Long Length

Dc 0 -0.03	R ±0.01	Lc m	L mm	d h6	Bright B282	TiAlN B282F	Bright B284	TiAlN B284F
3	1.5R	25	75	3	●	●	●	●
4	2R	28	75	4	●	●	●	●
5	2.5R	32	75	5	●	●	●	●
6	3R	38	100	6	●	●	●	●
8	4R	42	100	8	●	●	●	●
10	5R	45	100	10	●	●	●	●
12	6R	75	150	12	●	●	●	●
14	7R	80	150	14	●	●	●	●
16	8R	80	150	16	●	●	●	●
20	10R	80	150	20	●	●	●	●

End Mills For Aluminium

3 Flute Center Cutting

MG
Carbide
Uncoated
Bright

Code No: E133-DC

Work Material

P	H	M	K	N	S
				●	

N	Aluminium
---	-----------

N	Copper
---	--------

N	Plastics
---	----------

Tolerance: DC

All Sizes: +0/-0.03mm

Feature of product:

Application for universe cutting such as Aluminium, Copper, and Plastics.

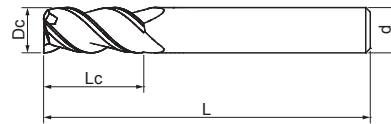

Standard Length

Dc 0 -0.03	Lc mm	L mm	d h5	Bright E133
1	3	38	3	●
1.5	5	38	3	●
2	6	38	3	●
2.5	7	38	3	●
3	9	38	3	●
4	14	50	4	●
5	16	50	5	●
6	20	63	6	●
7	20	63	8	●
8	20	63	8	●
9	22	72	10	●
10	22	72	10	●
12	26	75	12	●
14	32	89	14	●
16	32	89	16	●
18	38	100	18	●
20	38	100	20	●

End Mills For Aluminium 3 Flute Center Cutting

**MG
Carbide**
**Uncoated
Bright**

 45°

 12°
 90°

Code No: E135-DC

Code No: E136-DC

Code No: E137-DC

Work Material

P	H	M	K	N	S
				●	

N Aluminium

N Copper

N Plastics

Tolerance: DC
All Sizes: $+0/-0.03$ mm
Feature of product:

Application for universe cutting such as Aluminium, Copper, and Plastics.

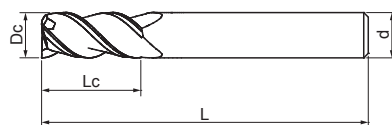

Long Length

Dc 0 -0.03	Lc mm	L mm	d h6	Bright E135	
3	20	57	3	●	
4	20	57	4	●	
5	25	63	5	●	
6	28	75	6	●	
7	30	75	8	●	
8	30	75	8	●	
9	32	75	10	●	
10	32	75	10	●	
12	50	100	12	●	
14	57	127	14	●	
16	57	127	16	●	
20	57	127	20	●	

Extra Long Length

Dc 0 -0.03	Lc mm	L mm	d h6	Bright E136	
3	25	75	3	●	
4	28	75	4	●	
5	32	75	5	●	
6	38	100	6	●	
8	42	100	8	●	
10	45	100	10	●	
12	75	150	12	●	
14	80	150	14	●	
16	80	150	16	●	
20	80	150	20	●	

Extra Long Length

Dc 0 -0.03	Lc mm	L mm	d h6	Bright E137	
6	50	100	6	●	
8	75	150	8	●	
10	75	150	10	●	
12	75	200	12	●	
16	75	200	16	●	
20	75	200	20	●	

Jobber Drills

118° Point for Quick Penetration

MG
 Carbide

Uncoated
Bright

Code No: D453-DC

Work Material

P	H	M	K	N	S
○			●	●	

P	Steel
----------	-------

K	Cast Iron
----------	-----------

N	Aluminium
----------	-----------

N	Copper
----------	--------

N	Plastics
----------	----------

N	FRP CFRP Composite Material
----------	--------------------------------

Tolerance: DC

All Sizes: h7

Feature of product:

Provide superior wear resistance. Use in lower tensile strength materials such as Cast Iron, Cast Aluminium, Bronze, Copper, Zinc, Brass, Rubber and Plastics, Composite...etc. Also can be applied for drilling with Steel as work material.

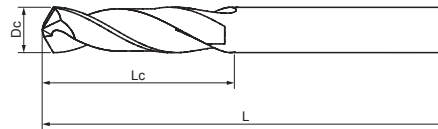

Standard Length

Dc h7	Lc mm	L mm	Bright D453
0.5	6	30	●
0.6	6	30	●
0.7	8	30	●
0.8	10	30	●
0.9	16	38	●
1	19	38	●
1.1	19	38	●
1.2	19	38	●
1.3	19	38	●
1.4	19	38	●
1.5	19	38	●
1.6	19	38	●
1.7	19	38	●
1.8	22	44	●
1.9	22	44	●
2	22	44	●
2.1	22	44	●
2.2	25	51	●
2.3	25	51	●
2.4	25	51	●
2.5	25	51	●
2.6	32	57	●
2.7	32	57	●
2.8	32	57	●
2.9	32	57	●
3	32	57	●
3.1	32	57	●
3.2	32	57	●
3.3	35	64	●
3.4	35	64	●
3.5	35	64	●
3.6	35	64	●
3.7	35	64	●
3.8	35	64	●
3.9	35	64	●
4	35	64	●
4.1	35	64	●
4.2	35	64	●
4.3	41	70	●
4.4	41	70	●
4.5	41	70	●
4.6	41	70	●

Jobber Drills

118° Point for Quick Penetration

MG
Carbide
Uncoated
Bright

Code No: D453-DC

Standard Length

Work Material

P	H	M	K	N	S
○			●	●	

P	Steel
----------	-------

K	Cast Iron
----------	-----------

N	Aluminium
----------	-----------

N	Copper
----------	--------

N	Plastics
----------	----------

N	FRP CFRP Composite Material
----------	--------------------------------

Tolerance: DC

All Sizes: h7

Feature of product:

Provide superior wear resistance.
 Use in lower tensile strength materials such as Cast Iron, Cast Aluminium, Bronze, Copper, Zinc, Brass, Rubber and Plastics, Composite...etc. Also can be applied for drilling with Steel as work material.

Dc h7	Lc mm	L mm	Bright D453
4.7	41	70	●
4.8	41	70	●
4.9	41	70	●
5	44	76	●
5.1	44	76	●
5.2	44	76	●
5.3	44	76	●
5.4	44	76	●
5.5	44	76	●
5.6	44	76	●
5.7	44	76	●
5.8	44	76	●
5.9	51	83	●
6	51	83	●
6.1	51	83	●
6.2	51	83	●
6.3	51	83	●
6.4	51	83	●
6.5	51	83	●
6.6	54	89	●
6.7	54	89	●
6.8	54	89	●
6.9	54	89	●
7	54	89	●
7.1	54	89	●
7.2	54	89	●
7.3	54	89	●
7.4	54	89	●
7.5	60	95	●
7.6	60	95	●
7.7	60	95	●
7.8	60	95	●
7.9	60	95	●
8	60	95	●
8.1	60	95	●
8.2	60	95	●
8.3	64	102	●
8.4	64	102	●
8.5	64	102	●
8.6	64	102	●
8.7	64	102	●
8.8	64	102	●
8.9	64	102	●
9	64	102	●
9.1	64	102	●
9.2	70	108	●
9.3	70	108	●
9.4	70	108	●
9.5	70	108	●
9.6	73	114	●
9.7	73	114	●
9.8	73	114	●
9.9	73	114	●
10	73	114	●
10.5	73	114	●
11	73	114	●
11.5	76	121	●
12	76	121	●

NC Machine Reamers

4&6 Flute Straight Shank Chucking Reamers

MG
 Carbide

 Uncoated
 Bright

Code No: R391-DC

Work Material

P	H	M	K	N	S
○	●	●	●	●	●

P	Steel
----------	-------

H	<48HRC Hardened Steel
----------	--------------------------

K	Cast Iron
----------	-----------

N	Aluminium
----------	-----------

N	Copper
----------	--------

N	Plastics
----------	----------

Tolerance: DC

+0.004/+0.008: 0.5-3.0
 +0.005/+0.010: 3.0-6.0
 +0.006/+0.012: 6.0-10
 +0.008/+0.015: 10-18

Feature of product:

Provide superior wear resistance.
 Can withstand the highest cutting temperatures in low tensile and highly abrasive materials such as Bronze, Copper, Rubber, Aluminium, Cast Iron, and Steel... etc.

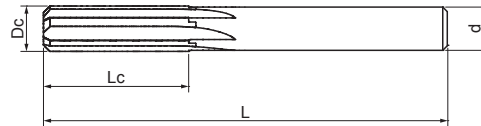

Standard Length

Dc H7	Dc mm	L mm	d mm	Z teeth	Bright R391
0.5	5	38	0.40	4	●
0.6	5	38	0.50	4	●
0.7	5	38	0.60	4	●
0.8	6	38	0.70	4	●
0.9	6	38	0.80	4	●
1	6	38	0.80	4	●
1.1	10	38	1.00	4	●
1.2	10	38	1.04	4	●
1.3	10	38	1.04	4	●
1.4	10	38	1.32	4	●
1.5	10	38	1.32	4	●
1.6	10	38	1.32	4	●
1.7	13	44	1.59	4	●
1.8	13	44	1.59	4	●
1.9	13	44	1.59	4	●
2	13	44	1.59	4	●
2.1	13	51	1.98	4	●
2.2	13	51	1.98	4	●
2.3	13	51	1.98	4	●
2.4	13	51	1.98	4	●
2.5	16	57	2.38	4	●
2.6	16	57	2.38	4	●
2.7	16	57	2.38	4	●
2.8	16	57	2.38	4	●
2.9	16	57	2.78	4	●
3	16	57	2.78	4	●
3.1	16	57	2.78	4	●
3.2	16	57	2.78	4	●
3.3	19	64	2.78	4	●
3.4	19	64	2.78	4	●
3.5	19	64	2.78	4	●
3.6	19	64	2.78	4	●
3.7	19	64	3.57	4	●
3.8	19	64	3.57	4	●

NC Machine Reamers

4&6 Flute Straight Shank Chucking Reamers

MG
 Carbide

 Uncoated
 Bright

0°



Code No: R391-DC

Standard Length

Dc H7	Dc mm	L mm	d mm	Z teeth	Bright R391	Dc H7	Dc mm	L mm	d mm	Z teeth	Bright R391
3.9	19	64	3.57	4	●	8.5	32	89	7.94	6	●
4	19	64	3.57	4	●	8.6	32	89	7.94	6	●
4.1	22	70	3.97	4	●	8.7	32	89	7.94	6	●
4.2	22	70	3.97	4	●	8.8	32	89	7.94	6	●
4.3	22	70	3.97	4	●	8.9	32	89	7.94	6	●
4.4	22	70	3.97	4	●	9	32	89	7.94	6	●
4.5	22	70	4.37	4	●	9.1	32	89	7.94	6	●
4.6	22	70	4.37	4	●	9.2	32	89	9.13	6	●
4.7	22	70	4.37	4	●	9.3	32	89	9.13	6	●
4.8	22	70	4.37	4	●	9.4	32	89	9.13	6	●
4.9	22	70	4.76	4	●	9.5	32	89	9.13	6	●
5	25	76	4.76	4	●	9.6	32	89	9.13	6	●
5.1	25	76	4.76	4	●	9.7	32	89	9.13	6	●
5.2	25	76	4.76	4	●	9.8	32	89	9.13	6	●
5.3	25	76	4.76	4	●	9.9	32	89	9.53	6	●
5.4	25	76	4.76	4	●	10	32	89	9.53	6	●
5.5	25	76	4.76	4	●	10.1	32	89	9.53	6	●
5.6	25	76	4.76	4	●	10.2	32	89	9.53	6	●
5.7	25	76	5.56	4	●	10.3	32	89	9.53	6	●
5.8	25	76	5.56	4	●	10.4	32	89	9.53	6	●
5.9	25	76	5.56	4	●	10.5	32	89	9.53	6	●
6	25	76	5.56	4	●	10.6	35	102	9.53	6	●
6.1	25	76	5.56	4	●	10.7	35	102	9.53	6	●
6.2	25	76	5.56	4	●	10.8	35	102	9.53	6	●
6.3	25	76	5.56	4	●	10.9	35	102	9.53	6	●
6.4	25	76	5.56	4	●	11	35	102	9.53	6	●
6.5	29	83	6.35	6	●	11.1	35	102	9.53	6	●
6.6	29	83	6.35	6	●	11.2	35	102	9.53	6	●
6.7	29	83	6.35	6	●	11.3	35	102	9.53	6	●
6.8	29	83	6.35	6	●	11.4	35	102	9.53	6	●
6.9	29	83	6.35	6	●	11.5	35	102	9.53	6	●
7	29	83	6.35	6	●	11.6	35	102	11.11	6	●
7.1	29	83	6.35	6	●	11.7	35	102	11.11	6	●
7.2	29	83	6.35	6	●	11.8	35	102	11.11	6	●
7.3	29	83	7.14	6	●	11.9	35	102	11.11	6	●
7.4	29	83	7.14	6	●	12	38	102	11.11	6	●
7.5	29	83	7.14	6	●	12.1	38	102	11.11	6	●
7.6	29	83	7.14	6	●	12.2	38	102	11.11	6	●
7.7	29	83	7.14	6	●	12.3	38	102	11.11	6	●
7.8	29	83	7.14	6	●	12.4	38	102	11.11	6	●
7.9	29	83	7.14	6	●	12.5	38	102	11.11	6	●
8	29	83	7.14	6	●	12.6	38	102	11.11	6	●
8.1	32	89	7.94	6	●	12.7	38	102	11.11	6	●
8.2	32	89	7.94	6	●	12.8	38	102	11.11	6	●
8.3	32	89	7.94	6	●	12.9	38	102	11.11	6	●
8.4	32	89	7.94	6	●	13	38	102	11.11	6	●

Work Material

P	H	M	K	N	S
○	●	●	●	●	●

P	Steel
----------	-------

H	<48HRC Hardened Steel
----------	--------------------------

K	Cast Iron
----------	-----------

N	Aluminium
----------	-----------

N	Copper
----------	--------

N	Plastics
----------	----------

Tolerance: DC

+0.004/+0.008: 0.5-3.0

+0.005/+0.010: 3.0-6.0

+0.006/+0.012: 6.0-10

+0.008/+0.015: 10-18

Feature of product:

Provide superior wear resistance.

Can withstand the highest cutting temperatures in low tensile and highly abrasive materials such as Bronze, Copper, Rubber, Aluminium, Cast Iron, and Steel... etc.

End Mills



Page	335	336	337	338	339	340
Appearance						
Code No	S445HX	E141-1HX	E141-2HX E141-3HX	F651SX	F652SX	F653TX
Carbide	MG Carbide	MG Carbide	MG Carbide	UMG Carbide	UMG Carbide	UMG Carbide
Coating	AlTiCrN HX	AlTiCrN HX	AlTiCrN HX	AlTiXN+ZrN SX	AlTiXN+ZrN SX	AlTiSiN TX
Helix Angle	 36° 38°	 38° 41°	 38° 41°	 38°	 38°	 38°
No. of Flutes	 Z=4	 Z=4	 Z=4	 Z=4	 Z=4	 Z=5

ANSI

341

342

343

344



E143-1

E143-2
E143-3

E133

E135
E136

MG
Carbide

MG
Carbide

MG
Carbide

MG
Carbide

Uncoated
Bright

Uncoated
Bright

Uncoated
Bright

Uncoated
Bright

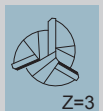

Easy Cut End Mills

4 Flute Center Cutting

MG
Carbide

AlTiCrN
HX

N

90°

Code No: S445HX-DC

Work Material

P	H	M	K	N	S
●	●	●	○	○	○

P	Steel
----------	-------

H	<48HRC Hardened Steel
----------	--------------------------

M	Stainless Steel
----------	-----------------

K	Cast Iron
----------	-----------

N	Aluminium
----------	-----------

N	Copper
----------	--------

S	Titanium
----------	----------

S	Nickel
----------	--------

S	High Temp Alloys
----------	------------------

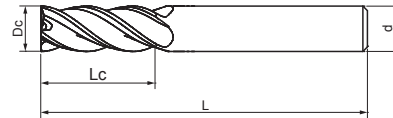

Standard Length

Dc 0 -0.001"	Lc Inch	L Inch	d h5	AlTiCrN S445HX
1/8	3/8	2	1/4	●
5/32	7/16	2	1/4	●
3/16	1/2	2	1/4	●
1/4	5/8	2	1/4	●
5/16	13/16	2-1/2	5/16	●
3/8	1	2-1/2	3/8	●
7/16	1	2-3/4	7/16	●
1/2	1	3	1/2	●
9/16	1-1/4	3-1/2	9/16	●
5/8	1-1/4	3-1/2	5/8	●
3/4	1-1/2	4	3/4	●
1	1-1/2	4	1	●

Tolerance: DC

All Sizes: +0/-0.001"

Feature of product:

Unique tool design can minimize chatter for smoother machining.

Single tool for roughing and finishing operations means fewer setups.

Application for Steel, Cast Iron, Stainless Steels, High Temp Alloys and also can be used in various Metal materials.

Multipurpose End Mills

4 Flute Center Cutting

MG
Carbide

AlTiCrN
HX

N

90°

Code No: E141-1HX-DC

Work Material

P	H	M	K	N	S
●	●	●	○	○	○

P	Steel
----------	-------

H	<48HRC Hardened Steel
----------	--------------------------

M	Stainless Steel
----------	-----------------

K	Cast Iron
----------	-----------

N	Aluminium
----------	-----------

N	Copper
----------	--------

S	Titanium
----------	----------

S	Nickel
----------	--------

S	High Temp Alloys
----------	------------------

Tolerance: DC

All Sizes: +0/-0.001"

Feature of product:

Unique tool design can minimize chatter for smoother machining.

Single tool for roughing and finishing operations means fewer setups.

Application for Steel, Cast Iron, Stainless Steels, High Temp Alloys and also can be used in various Metal materials.

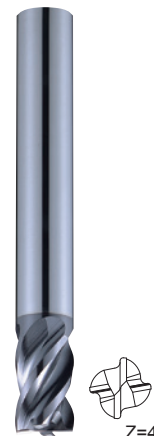
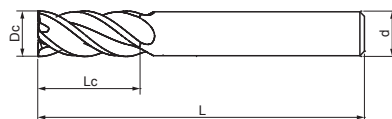

Stub Length

Dc 0 -0.001"	Lc Inch	L Inch	d h5	AlTiCrN E141-1HX
1/8	1/4	1-1/2	1/8	●
5/32	3/8	2	3/16	●
3/16	3/8	2	3/16	●
1/4	3/8	2	1/4	●
5/16	7/16	2	5/16	●
3/8	1/2	2	3/8	●
7/16	9/16	2-1/2	7/16	●
1/2	5/8	2-1/2	1/2	●

Multipurpose End Mills

4 Flute Center Cutting

MG
Carbide

AlTiCrN
HX

N

90°

Code No: E141-2HX-DC

Code No: E141-3HX-DC

Work Material

P	H	M	K	N	S
●	●	●	○	○	○

P	Steel
----------	-------

H	<48HRC Hardened Steel
----------	--------------------------

M	Stainless Steel
----------	-----------------

K	Cast Iron
----------	-----------

N	Aluminium
----------	-----------

N	Copper
----------	--------

S	Titanium
----------	----------

S	Nickel
----------	--------

S	High Temp Alloys
----------	------------------

Tolerance: DC

All Sizes: +0/-0.001"

Feature of product:

Unique tool design can minimize chatter for smoother machining.

Single tool for roughing and finishing operations means fewer setups.

Application for Steel, Cast Iron, Stainless Steels, High Temp Alloys and also can be used in various Metal materials.

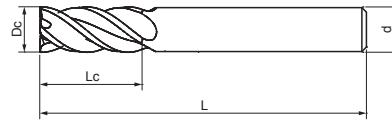

Standard Length

Dc 0 -0.001"	Lc Inch	L Inch	d h5	AlTiCrN E141-2HX	
1/8	1/2	1-1/2	1/8	●	
5/32	9/16	2	3/16	●	
3/16	5/8	2	3/16	●	
1/4	3/4	2-1/2	1/4	●	
5/16	13/16	2-1/2	5/16	●	
3/8	1	2-1/2	3/8	●	
7/16	1	2-3/4	7/16	●	
1/2	1-1/4	3	1/2	●	
9/16	1-1/4	3-1/2	9/16	●	
5/8	1-5/8	3-1/2	5/8	●	
3/4	1-5/8	4	3/4	●	
1	2	4	1	●	

Long Length

Dc 0 -0.001"	Lc Inch	L Inch	d h5	AlTiCrN E141-3HX	
1/8	3/4	3	1/8	●	
3/16	3/4	3	3/16	●	
1/4	1-1/4	3	1/4	●	
5/16	1-3/8	3	5/16	●	
3/8	1-1/2	4	3/8	●	
7/16	2	4	7/16	●	
1/2	2	4	1/2	●	
5/8	2-1/4	5	5/8	●	
3/4	2-1/4	5	3/4	●	
1	3-1/4	6	1	●	

End Mills For Difficult To Cut Materials

4 Flute Center Cutting

UMG
Carbide

AlTiXN+ZrN
SX

Code No: F651SX-DC

Work Material

P	H	M	K	N	S
●	●	●	●	●	●

P	Steel
----------	-------

H	<48HRC Hardened Steel
----------	--------------------------

M	Stainless Steel
----------	-----------------

K	Cast Iron
----------	-----------

S	Titanium
----------	----------

S	Nickel
----------	--------

S	High Temp Alloys
----------	------------------

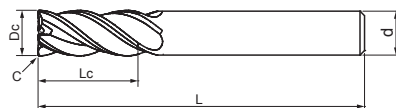

Standard Length

Dc 0 -0.001"	Lc Inch	L Inch	d h5	C Inch	AlTiXN+ZrN F651SX
1/8	1/2	1-1/2	1/8	0.1	●
5/32	9/16	2	3/16	0.1	●
3/16	5/8	2	3/16	0.15	●
1/4	3/4	2-1/2	1/4	0.15	●
5/16	13/16	2-1/2	5/16	0.15	●
3/8	1	2-1/2	3/8	0.2	●
7/16	1	2-3/4	7/16	0.2	●
1/2	1-1/4	3	1/2	0.2	●
5/8	1-5/8	3-1/2	5/8	0.2	●
3/4	1-5/8	4	3/4	0.2	●
1	2	4	1	0.2	●

Tolerance: DC

All Sizes: +0/-0.001"

Feature of product:

Application for roughing and finishing cutting in different materials.

Sharp cutting edge is suitable for cutting Steel, Stainless Steels, Titanium, Nickel and High Temp Alloys... etc.

End Mills With Corner Radius For Difficult To Cut Materials 4 Flute Center Cutting

UMG
CarbideAlTiXN+ZrN
SX

Code No: F652SX-DC×R

Work Material

P	H	M	K	N	S
●	●	●	●	●	●

P	Steel
H	<48HRC Hardened Steel
M	Stainless Steel
K	Cast Iron
S	Titanium
S	Nickel
S	High Temp Alloys

Tolerance: DC

All Sizes: +0/-0.001"

Feature of product:

Application for roughing and finishing cutting in different materials.

Sharp cutting edge is suitable for cutting Steel, Stainless Steels, Titanium, Nickel and High Temp Alloys... etc.

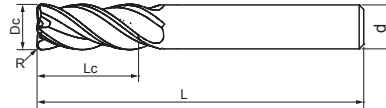

Standard Length

Dc 0 -0.001"	R Inch	Lc Inch	L Inch	d h5	AlTiXN+ZrN F652SX
1/8	0.010R	1/2	1-1/2	1/8	●
1/8	0.015R	1/2	1-1/2	1/8	●
1/8	0.030R	1/2	1-1/2	1/8	●
3/16	0.010R	5/8	2	3/16	●
3/16	0.015R	5/8	2	3/16	●
3/16	0.030R	5/8	2	3/16	●
1/4	0.015R	3/4	2-1/2	1/4	●
1/4	0.020R	3/4	2-1/2	1/4	●
1/4	0.030R	3/4	2-1/2	1/4	●
1/4	0.060R	3/4	2-1/2	1/4	●
5/16	0.015R	13/16	2-1/2	5/16	●
5/16	0.020R	13/16	2-1/2	5/16	●
5/16	0.030R	13/16	2-1/2	5/16	●
5/16	0.060R	13/16	2-1/2	5/16	●
5/16	0.090R	13/16	2-1/2	5/16	●
3/8	0.015R	1	2-1/2	3/8	●
3/8	0.020R	1	2-1/2	3/8	●
3/8	0.030R	1	2-1/2	3/8	●
3/8	0.060R	1	2-1/2	3/8	●
3/8	0.090R	1	2-1/2	3/8	●
1/2	0.015R	1-1/4	3	1/2	●
1/2	0.030R	1-1/4	3	1/2	●
1/2	0.060R	1-1/4	3	1/2	●
1/2	0.090R	1-1/4	3	1/2	●
1/2	0.120R	1-1/4	3	1/2	●
5/8	0.030R	1-5/8	3-1/2	5/8	●
5/8	0.060R	1-5/8	3-1/2	5/8	●
5/8	0.090R	1-5/8	3-1/2	5/8	●
5/8	0.120R	1-5/8	3-1/2	5/8	●
3/4	0.030R	1-5/8	4	3/4	●
3/4	0.060R	1-5/8	4	3/4	●
3/4	0.090R	1-5/8	4	3/4	●
3/4	0.120R	1-5/8	4	3/4	●
1	0.030R	2	4	1	●
1	0.060R	2	4	1	●
1	0.090R	2	4	1	●
1	0.120R	2	4	1	●

End Mills With Corner Radius For Difficult To Cut Materials 5 Flute Center Cutting

UMG
CarbideAITiSiN
TX

Code No: F653TX-DC×R

Work Material

P	H	M	K	N	S
●	●	●	●	●	●

P	Steel
H	<48HRC Hardened Steel
M	Stainless Steel
K	Cast Iron
S	Titanium
S	Nickel
S	High Temp Alloys

Tolerance: DC

All Sizes: +0/-0.001"

Feature of product:

Application for HPC/ roughing cutting and HSC/ finishing cutting.

Sharp cutting edge is suitable for cutting Steel, Stainless Steels, Titanium, Nickel and High Temp Alloys... etc.

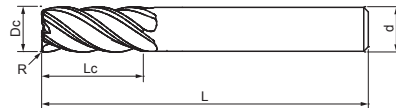

Standard Length

Dc 0 -0.001"	R ±0.0005	Lc Inch	L Inch	d h5	AITiSiN F653TX
1/8	0.010R	1/2	1-1/2	1/8	●
1/8	0.015R	1/2	1-1/2	1/8	●
1/8	0.030R	1/2	1-1/2	1/8	●
3/16	0.010R	5/8	2	3/16	●
3/16	0.015R	5/8	2	3/16	●
3/16	0.030R	5/8	2	3/16	●
1/4	0.015R	3/4	2-1/2	1/4	●
1/4	0.020R	3/4	2-1/2	1/4	●
1/4	0.030R	3/4	2-1/2	1/4	●
1/4	0.060R	3/4	2-1/2	1/4	●
5/16	0.015R	13/16	2-1/2	5/16	●
5/16	0.020R	13/16	2-1/2	5/16	●
5/16	0.030R	13/16	2-1/2	5/16	●
5/16	0.060R	13/16	2-1/2	5/16	●
5/16	0.090R	13/16	2-1/2	5/16	●
3/8	0.015R	1	2-1/2	3/8	●
3/8	0.020R	1	2-1/2	3/8	●
3/8	0.030R	1	2-1/2	3/8	●
3/8	0.060R	1	2-1/2	3/8	●
3/8	0.090R	1	2-1/2	3/8	●
1/2	0.015R	1-1/4	3	1/2	●
1/2	0.030R	1-1/4	3	1/2	●
1/2	0.060R	1-1/4	3	1/2	●
1/2	0.090R	1-1/4	3	1/2	●
1/2	0.120R	1-1/4	3	1/2	●
5/8	0.030R	1-5/8	3-1/2	5/8	●
5/8	0.060R	1-5/8	3-1/2	5/8	●
5/8	0.090R	1-5/8	3-1/2	5/8	●
5/8	0.120R	1-5/8	3-1/2	5/8	●
3/4	0.030R	1-5/8	4	3/4	●
3/4	0.060R	1-5/8	4	3/4	●
3/4	0.090R	1-5/8	4	3/4	●
3/4	0.120R	1-5/8	4	3/4	●
1	0.030R	2	4	1	●
1	0.060R	2	4	1	●
1	0.090R	2	4	1	●
1	0.120R	2	4	1	●

End Mills For Aluminium 3 Flute Center Cutting

**MG
Carbide**
**Uncoated
Bright**

40°



72°

N

90°

Code No: E143-1-DC

Work Material

P	H	M	K	N	S
				●	

N	Aluminium
---	-----------

Tolerance: DC

All Sizes: +0/-0.001"

Feature of product:

Designed for maximum metal removal rates, superior surface finishes and better anti-vibration rate.

Use for Aluminium which from roughing to finishing operations with one tool.

High spiral and optimal rake angle allow reduce cutting forces.

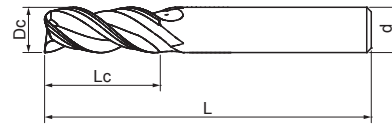

Standard Length

Dc 0 -0.001"	Lc Inch	L Inch	d h5	Bright E143-1
1/8	1/4	1-1/2	1/8	●
5/32	3/8	2	3/16	●
3/16	3/8	2	3/16	●
1/4	3/8	2	1/4	●
5/16	7/16	2	5/16	●
3/8	1/2	2	3/8	●
7/16	9/16	2-1/2	7/16	●
1/2	5/8	2-1/2	1/2	●

Z=3

End Mills For Aluminium 3 Flute Center Cutting

**MG
Carbide**
**Uncoated
Bright**

90°

Code No: E143-2-DC

Code No: E143-3-DC

Work Material

P	H	M	K	N	S
				●	

N Aluminium

Tolerance: DC

All Sizes: +0/-0.001"

Feature of product:

Designed for maximum metal removal rates, superior surface finishes and better anti-vibration rate.

Use for Aluminium which from roughing to finishing operations with one tool.

High spiral and optimal rake angle allow reduce cutting forces.

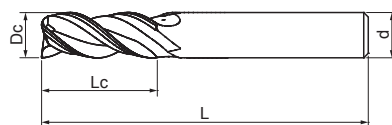

Long Length

Dc 0 -0.001"	Lc Inch	L Inch	d h5	Bright E143-2	
1/8	1/2	1-1/2	1/8	●	
5/32	9/16	2	3/16	●	
3/16	5/8	2	3/16	●	
1/4	3/4	2-1/2	1/4	●	
5/16	13/16	2-1/2	5/16	●	
3/8	1	2-1/2	3/8	●	
7/16	1	2-3/4	7/16	●	
1/2	1-1/4	3	1/2	●	
9/16	1-1/4	3-1/2	9/16	●	
5/8	1-5/8	3-1/2	5/8	●	
3/4	1-5/8	4	3/4	●	
1	2	4	1	●	

Extra Long Length

Dc 0 -0.001"	Lc Inch	L Inch	d h5	Bright E143-3	
1/8	3/4	3	1/8	●	
3/16	3/4	3	3/16	●	
1/4	1-1/4	3	1/4	●	
5/16	1-3/8	3	5/16	●	
3/8	1-1/2	4	3/8	●	
7/16	2	4	7/16	●	
1/2	2	4	1/2	●	
5/8	2-1/4	5	5/8	●	
3/4	2-1/4	5	3/4	●	
1	3-1/4	6	1	●	

End Mills For Aluminium 3 Flute Center Cutting

**MG
Carbide**
**Uncoated
Bright**

Code No: E133-DC

Work Material

P	H	M	K	N	S
				●	

N	Aluminium
---	-----------

N	Copper
---	--------

N	Plastics
---	----------

Tolerance: DC

All Sizes: +0/-0.001"

Feature of product:

Application for universe cutting such as Aluminium, Copper, and Plastics.

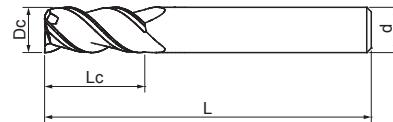

Standard Length

Dc 0 -0.001"	Lc Inch	L Inch	d h6	Bright E133
1/32	3/32	1-1/2	1/8	●
3/64	1/8	1-1/2	1/8	●
1/16	3/16	1-1/2	1/8	●
5/64	1/4	1-1/2	1/8	●
3/32	3/8	1-1/2	1/8	●
7/64	3/8	1-1/2	1/8	●
1/8	1/2	1-1/2	1/8	●
5/32	9/16	2	3/16	●
3/16	5/8	2	3/16	●
7/32	5/8	2-1/2	1/4	●
1/4	3/4	2-1/2	1/4	●
9/32	3/4	2-1/2	5/16	●
5/16	13/16	2-1/2	5/16	●
3/8	1	2-1/2	3/8	●
7/16	1	2-3/4	7/16	●
1/2	1	3	1/2	●
9/16	1-1/4	3-1/2	9/16	●
5/8	1-1/4	3-1/2	5/8	●
3/4	1-1/2	4	3/4	●
1	1-1/2	4	1	●

Z=3

End Mills For Aluminium 3 Flute Center Cutting

**MG
Carbide**
**Uncoated
Bright**

Code No: E135-DC

Code No: E136-DC

Work Material

P	H	M	K	N	S
				●	

N Aluminium

N Copper

N Plastics

Tolerance: DC

All Sizes: +0/-0.001"

Feature of product:

Application for universe cutting such as Aluminium, Copper, and Plastics.

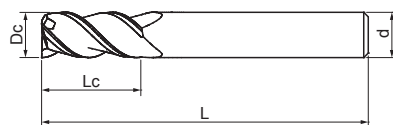

Long Length

Dc ⁰ -0.001"	Lc Inch	L Inch	d h6	Bright E135	
1/8	3/4	2-1/4	1/8	●	
3/16	3/4	2-1/2	3/16	●	
1/4	1-1/8	3	1/4	●	
5/16	1-1/8	3	5/16	●	
3/8	1-1/8	3	3/8	●	
7/16	2	4	7/16	●	
1/2	2	4	1/2	●	
5/8	2-1/4	5	5/8	●	
3/4	2-1/4	5	3/4	●	
1	2-1/4	5	1	●	

Extra Long Length

Dc ⁰ -0.001"	Lc Inch	L Inch	d h6	Bright E136	
1/8	1	3	1/8	●	
3/16	1-1/8	3	3/16	●	
1/4	1-1/2	4	1/4	●	
5/16	1-5/8	4	5/16	●	
3/8	1-3/4	4	3/8	●	
7/16	3	6	7/16	●	
1/2	3	6	1/2	●	
5/8	3	6	5/8	●	
3/4	3	6	3/4	●	
1	3	6	1	●	

End Mills

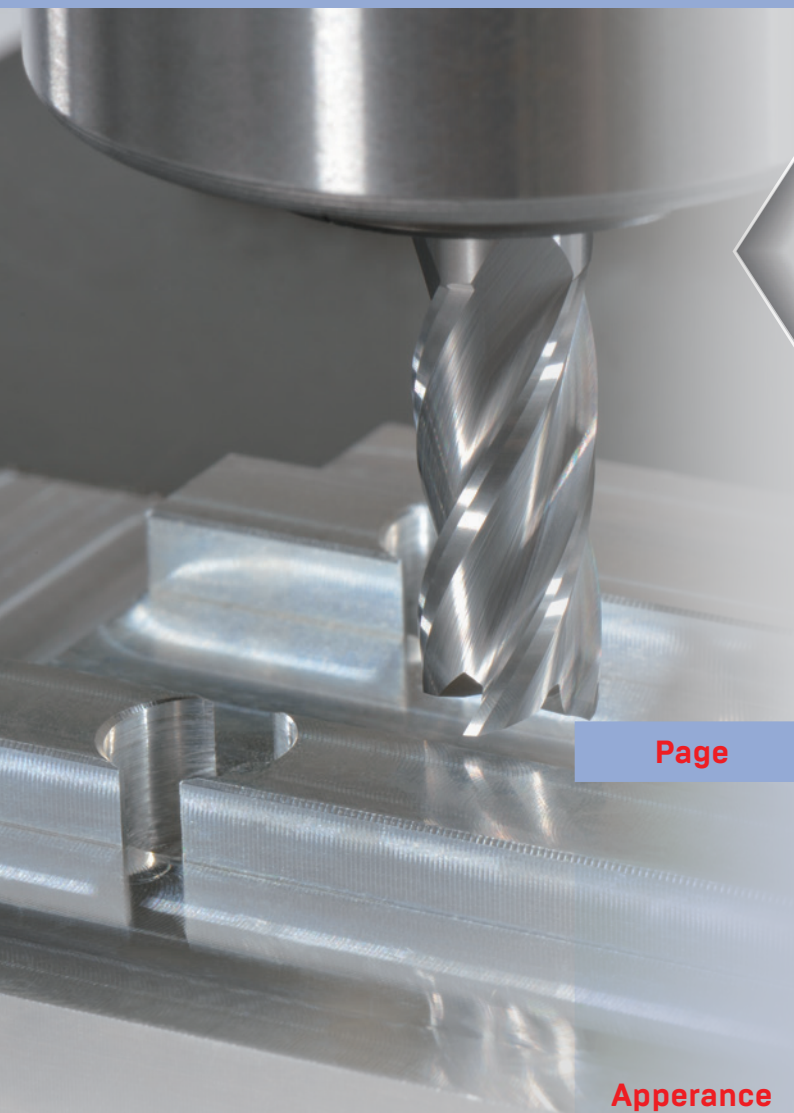

Page	347	347	348	348	349	350
Apperance						
Code No	E172	E174	E182 E185	E184 E186	E166TX	F608HX
Carbide	MG Carbide	MG Carbide	MG Carbide	MG Carbide	SMG Carbide	UMG Carbide
Coating	Bright TiAIN	Bright TiAIN	Bright TiAIN	Bright TiAIN	AlTiSiN TX	AlTiCrN HX
Helix Angle	30°	30°	30°	30°	45°	20°
No.of Flutes	2	4	2	4	Z=6~10	Z=3~5

ANSI

351	351	352	352	353	354	355	356	357
								
B212	B214	B280 B282	B281 B284	E191	E197 E198 E199	E106 E107	E108 E109	E100HX
MG Carbide	MG Carbide	MG Carbide	MG Carbide	MG Carbide	MG Carbide	MG Carbide	MG Carbide	MG Carbide
Bright TiAlN	Bright TiAlN	Bright TiAlN	Bright TiAlN	Uncoated Bright	Uncoated Bright	Bright AlTiN	Bright AlTiN	AlTiCrN HX
 30°	 30°	 30°	 30°			 30°	 0°	 15°
 Z=2	 Z=4	 Z=2	 Z=4			 Z=2	 Z=4	

Square End Mills

2&4 Flute Center Cutting

MG
 Carbide

Bright
 TiAlN



30°



γ10°

90°

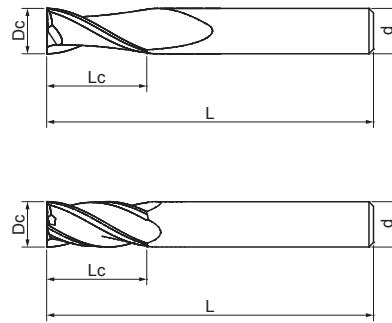
Code No: E172-DC / E174-DC



Work Material

P	H	M	K	N	S
●	○	○	○	○	○

P	Steel
M	Stainless Steel
K	Cast Iron
N	Aluminium
N	Copper
N	Plastics
S	Titanium
S	Nickel

Tolerance: DC

All Sizes: +0/-0.001"

Feature of product:

Center Cutting tools are used in a variety of applications including plunging, drilling or ramping....

TiAlN is one of abrasive resistant coatings. It is commonly used for machining aircraft and aerospace material, Nickel Alloys, Stainless Steels, Titanium, Cast Iron and Steel.

Standard Length

Dc 0 -0.001"	Lc Inch	L Inch	d h6	Bright E172	TiAlN E172F	Bright E174	TiAlN E174F
1/32	3/32	1-1/2	1/8	●	●		
3/64	1/8	1-1/2	1/8	●	●		
1/16	3/16	1-1/2	1/8	●	●	●	●
5/64	1/4	1-1/2	1/8	●	●	●	●
3/32	3/8	1-1/2	1/8	●	●	●	●
7/64	3/8	1-1/2	1/8	●	●	●	●
1/8	1/2	1-1/2	1/8	●	●	●	●
5/32	9/16	2	3/16	●	●	●	●
3/16	5/8	2	3/16	●	●	●	●
7/32	5/8	2-1/2	1/4	●	●	●	●
1/4	3/4	2-1/2	1/4	●	●	●	●
9/32	3/4	2-1/2	5/16	●	●	●	●
5/16	13/16	2-1/2	5/16	●	●	●	●
3/8	1	2-1/2	3/8	●	●	●	●
7/16	1	2-3/4	7/16	●	●	●	●
1/2	1	3	1/2	●	●	●	●
9/16	1-1/4	3-1/2	9/16	●	●	●	●
5/8	1-1/4	3-1/2	5/8	●	●	●	●
3/4	1-1/2	4	3/4	●	●	●	●
1	1-1/2	4	1	●	●	●	●

Square End Mills

2&4 Flute Center Cutting

MG
 Carbide

Bright
 TiAlN

30°



γ10°

90°

Code No: E182-DC / E184-DC

Code No: E185-DC / E186-DC

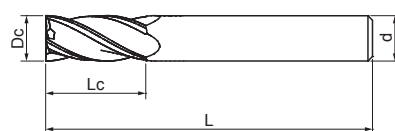
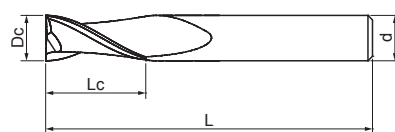

Z=2



Z=4

Work Material

P	H	M	K	N	S
●	○	○	○	○	○

P	Steel
----------	-------

M	Stainless Steel
----------	-----------------

K	Cast Iron
----------	-----------

N	Aluminium
----------	-----------

N	Copper
----------	--------

N	Plastics
----------	----------

S	Titanium
----------	----------

S	Nickel
----------	--------

Tolerance: DC

All Sizes: +0/-0.001"

Feature of product:

Center Cutting tools are used in a variety of applications including plunging, drilling or ramping....

TiAlN is one of abrasive resistant coatings. It is commonly used for machining aircraft and aerospace material, Nickel Alloys, Stainless Steels, Titanium, Cast Iron and Steel.

Long Length

Dc 0 -0.001"	Lc Inch	L Inch	d h6	Bright E182	TiAlN E182F	Bright E184	TiAlN E184F
1/8	3/4	2-1/4	1/8	●	●	●	●
3/16	3/4	2-1/2	3/16	●	●	●	●
1/4	1-1/8	3	1/4	●	●	●	●
5/16	1-1/8	3	5/16	●	●	●	●
3/8	1-1/8	3	3/8	●	●	●	●
7/16	2	4	7/16	●	●	●	●
1/2	2	4	1/2	●	●	●	●
5/8	2-1/4	5	5/8	●	●	●	●
3/4	2-1/4	5	3/4	●	●	●	●
1	2-1/4	5	1	●	●	●	●

Extra Long Length

Dc 0 -0.001"	Lc Inch	L Inch	d h6	Bright E185	TiAlN E185F	Bright E186	TiAlN E186F
1/8	1	3	1/8	●	●	●	●
3/16	1-1/8	3	3/16	●	●	●	●
1/4	1-1/2	4	1/4	●	●	●	●
5/16	1-5/8	4	5/16	●	●	●	●
3/8	1-3/4	4	3/8	●	●	●	●
7/16	3	6	7/16	●	●	●	●
1/2	3	6	1/2	●	●	●	●
5/8	3	6	5/8	●	●	●	●
3/4	3	6	3/4	●	●	●	●
1	3	6	1	●	●	●	●

Finishing End Mills

6&8&10 Flute Center Cutting

SMG
Carbide

AlTiSiN
TX

45°



7-10°



45°

0.004"-0.008"

Code No: E166TX-DC

Work Material

P	H	M	K	N	S
	●		○		○

H	<40~70HRC Hardened Steel
----------	-----------------------------

K	Cast Iron
----------	-----------

S	Titanium
----------	----------

S	High Temp Alloys
----------	------------------

Tolerance: DC

All Sizes: +0/-0.001"

Feature of product:

Recommended for tough materials such as High hardened Steels, Stainless Steels, High Temp Alloys, and Titanium.

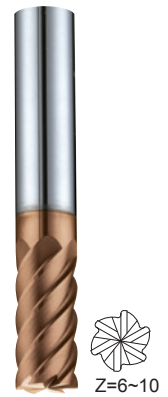
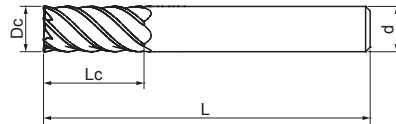

Standard Length

Dc 0 -0.001"	Lc Inch	L Inch	d h5	No. of Flute	AlTiSiN E166TX
1/4	3/4	2-1/2	1/4	6	●
5/16	13/16	2-1/2	5/16	6	●
3/8	1	2-1/2	3/8	6	●
1/2	1	3	1/2	6	●
5/8	1-1/4	3-1/2	5/8	6	●
3/4	1-1/2	4	3/4	8	●
1	1-1/2	4	1	10	●

Z=6~10

Roughing End Mills

3&4&5 Flute Center Cutting

UMG
Carbide

AlTiCrN
HX

20°



HR

45°

Code No: F608HX-DC

Work Material

P	H	M	K	N	S
●	●	○	●	■	■

P	Steel
----------	-------

H	<48HRC Hardened Steel
----------	--------------------------

M	Stainless Steel
----------	-----------------

K	Cast Iron
----------	-----------

Tolerance: DC

All Sizes: h10

Feature of product:

20° Helix angle provides for greater edge support and shock absorption.

Fine Profile for optimum metal removal rates.

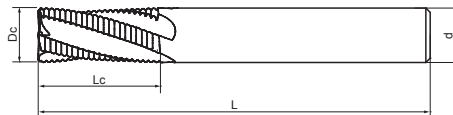

Z=3~5

Standard Length

Dc h10	Lc Inch	L Inch	d h5	No. of Flute	C Inch	AlTiCrN F608HX
1/4	3/4	2-1/2	1/4	3	0.020	●
5/16	13/16	2-1/2	5/16	4	0.020	●
3/8	1	2-1/2	3/8	4	0.020	●
7/16	1	2-3/4	7/16	4	0.020	●
1/2	1	3	1/2	4	0.025	●
5/8	1-1/4	3-1/2	5/8	4	0.025	●
3/4	1-1/2	4	3/4	4	0.025	●
1	1-1/2	4	1	5	0.025	●

Ball Nose End Mills

2&4 Flute Center Cutting

MG
Carbide
Bright
TiAlN

30°



H

γ10°



Code No: B212-DC / B214-DC

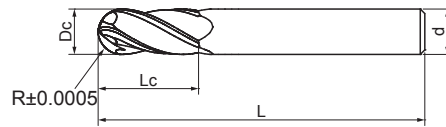
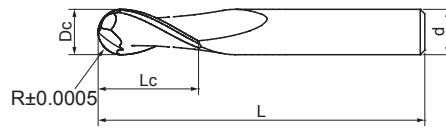

Work Material

P	H	M	K	N	S
●	○	○	○	○	○

P	Steel
----------	-------

M	Stainless Steel
----------	-----------------

K	Cast Iron
----------	-----------

N	Aluminium
----------	-----------

N	Copper
----------	--------

N	Plastics
----------	----------

S	Titanium
----------	----------

S	Nickel
----------	--------

Tolerance: DC

All Sizes: +0/-0.001"

Feature of product:

Provide better rigidity and heat resistant.

Use for high speed applications on cast iron, nonferrous materials, plastics and other tough-to-machine materials.

TiAlN is one of the abrasive resistant coatings. It is commonly used for machining aircraft and aerospace material, Nickel Alloys, Stainless Steels, Titanium, Cast Iron and Steel.

Standard Length

Dc 0 -0.001"	Lc Inch	L Inch	d h6	Bright B212	TiAlN B212F	Bright B214	TiAlN B214F
1/32	3/32	1-1/2	1/8	●	●		
3/64	1/8	1-1/2	1/8	●	●		
1/16	3/16	1-1/2	1/8	●	●	●	●
5/64	1/4	1-1/2	1/8	●	●	●	●
3/32	3/8	1-1/2	1/8	●	●	●	●
7/64	3/8	1-1/2	1/8	●	●	●	●
1/8	1/2	1-1/2	1/8	●	●	●	●
5/32	9/16	2	3/16	●	●	●	●
3/16	5/8	2	3/16	●	●	●	●
7/32	5/8	2-1/2	1/4	●	●	●	●
1/4	3/4	2-1/2	1/4	●	●	●	●
9/32	3/4	2-1/2	5/16	●	●	●	●
5/16	13/16	2-1/2	5/16	●	●	●	●
3/8	1	2-1/2	3/8	●	●	●	●
7/16	1	2-3/4	7/16	●	●	●	●
1/2	1	3	1/2	●	●	●	●
9/16	1-1/4	3-1/2	9/16	●	●	●	●
5/8	1-1/4	3-1/2	5/8	●	●	●	●
3/4	1-1/2	4	3/4	●	●	●	●
1	1-1/2	4	1	●	●	●	●

Ball Nose End Mills

2&4 Flute Center Cutting

MG
Carbide
Bright
TiAlN

30°



γ10°



Code No: B280-DC / B281-DC

Code No: B282-DC / B284-DC

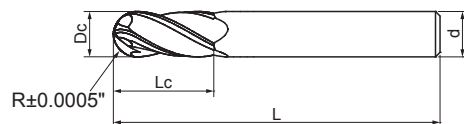
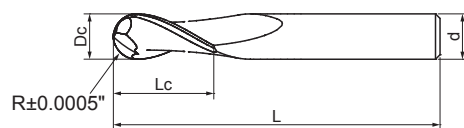

Z=2



Z=4

Work Material

P	H	M	K	N	S
●	○	○	○	○	○

P	Steel
----------	-------

M	Stainless Steel
----------	-----------------

K	Cast Iron
----------	-----------

N	Aluminium
----------	-----------

N	Copper
----------	--------

N	Plastics
----------	----------

S	Titanium
----------	----------

S	Nickel
----------	--------

Tolerance: DC

All Sizes: +0/-0.001"

Feature of product:

Provide better rigidity and heat resistant.

Use for high speed applications on cast iron, nonferrous materials, plastics and other tough-to-machine materials.

TiAlN is one of the abrasive resistant coatings. It is commonly used for machining aircraft and aerospace material, Nickel Alloys, Stainless Steels, Titanium, Cast Iron and Steel.

Long Length

Dc 0 -0.001"	Lc Inch	L Inch	d h6	Bright B280	TiAlN B280F	Bright B281	TiAlN B281F
1/8	3/4	2-1/4	1/8	●	●	●	●
3/16	3/4	2-1/2	3/16	●	●	●	●
1/4	1-1/8	3	1/4	●	●	●	●
5/16	1-1/8	3	5/16	●	●	●	●
3/8	1-1/8	3	3/8	●	●	●	●
7/16	2	4	7/16	●	●	●	●
1/2	2	4	1/2	●	●	●	●
5/8	2-1/4	5	5/8	●	●	●	●
3/4	2-1/4	5	3/4	●	●	●	●
1	2-1/4	5	1	●	●	●	●

Extra Long Length

Dc 0 -0.001"	Lc Inch	L Inch	d h6	Bright B282	TiAlN B282F	Bright B284	TiAlN B284F
1/8	1	3	1/8	●	●	●	●
3/16	1-1/8	3	3/16	●	●	●	●
1/4	1-1/2	4	1/4	●	●	●	●
5/16	1-5/8	4	5/16	●	●	●	●
3/8	1-3/4	4	3/8	●	●	●	●
7/16	3	6	7/16	●	●	●	●
1/2	3	6	1/2	●	●	●	●
5/8	3	6	5/8	●	●	●	●
3/4	3	6	3/4	●	●	●	●
1	3	6	1	●	●	●	●

Routing End Mills

Multiple Flutes Routers For Composite

**MG
Carbide**
**Uncoated
Bright**

Code No: E191-DC

Work Material

P	H	M	K	N	S
				●	

N	FRP CFRP Composite Material
----------	--------------------------------

N	Graphite
----------	----------

Tolerance: DC

All Sizes: +0/-0.002"

Feature of product:

Application for Phenolic-epoxy parts, Polyester glass reinforced products, Graphite, Composite...etc.

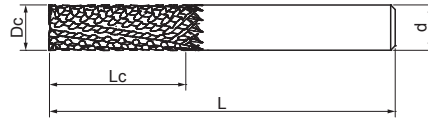

Standard Length

Dc 0 -0.002"	Lc Inch	L Inch	d h6	Bright E191
1/8	1/2	2	1/8	●
3/16	5/8	2	3/16	●
1/4	3/4	3	1/4	●
5/16	3/4	3	5/16	●
3/8	1-1/8	3-1/2	3/8	●
1/2	1-1/8	3-1/2	1/2	●

Routing End Mills

Multiple Flutes Routers For Composite

**MG
Carbide**
**Uncoated
Bright**

Code No: E197-DC

Code No: E198-DC

Code No: E199-DC

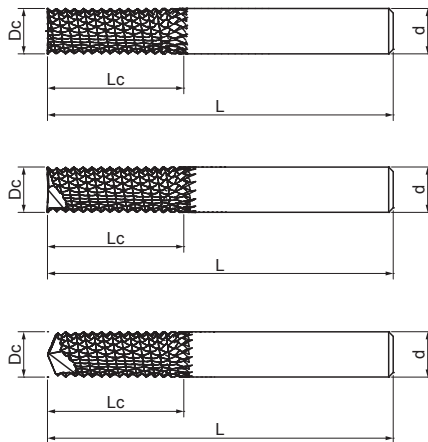

Work Material

P	H	M	K	N	S
				●	

N	FRP CFRP Composite Material
----------	--------------------------------

N	Graphite
----------	----------

Tolerance: DC

All Sizes: +0/-0.002"

Feature of product:

Application for Phenolic-epoxy parts, Polyester glass reinforced products, Graphite, Composite...etc.

Standard Length

Dc 0 -0.002"	Lc Inch	L Inch	d h6	Bright E197	Bright E198	Bright E199
1/8	1/2	1-1/2	1/8	●	●	●
3/16	5/8	2	3/16	●	●	●
1/4	1	3	1/4	●	●	●
5/16	1	3	5/16	●	●	●
3/8	1	3	3/8	●	●	●
1/2	1-1/8	3	1/2	●	●	●

Chamfer Mills

2 Flute Chamfering 60° & 90°

MG
 Carbide

Bright
 AlTiN

Code No: E106-DC-60°

Code No: E107-DC-90°

Work Material

P	H	M	K	N	S
●	●	○	●	●	○

P	Steel
H	<48HRC Hardened Steel
M	Stainless Steel
K	Cast Iron
N	Aluminium
N	Copper

Tolerance: DC

All Sizes: +0/-0.001"

Feature of product:

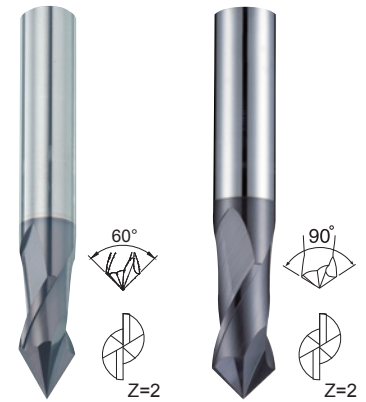
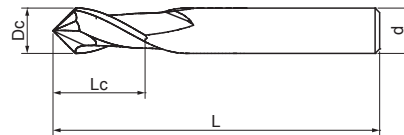
 Application for drilling,
 chamfering, countersink, spotting,
 and profile milling.

Standard Length

Dc 0 -0.001"	Lc Inch	L Inch	d h6	Bright E106	AlTiN E106X	Bright E107	AlTiN E107X
1/16	3/16	1-1/2	1/8	●	●	●	●
3/32	3/8	1-1/2	1/8	●	●	●	●
1/8	1/2	1-1/2	1/8	●	●	●	●
3/16	5/8	2	3/16	●	●	●	●
1/4	3/4	2-1/2	1/4	●	●	●	●
5/16	13/16	2-1/2	5/16	●	●	●	●
3/8	1	2-1/2	3/8	●	●	●	●
7/16	1	2-3/4	7/16	●	●	●	●
1/2	1	3	1/2	●	●	●	●
5/8	1-1/4	3-1/2	5/8	●	●	●	●
3/4	1-1/2	4	3/4	●	●	●	●

Chamfer Mills

4 Flute Chamfering 60° & 90°

MG
 Carbide

Bright
 AlTiN

Code No: E108-DC-60°

Code No: E109-DC-90°

Work Material

P	H	M	K	N	S
●	●	○	●	●	○

P	Steel
----------	-------

H	<48HRC Hardened Steel
----------	--------------------------

M	Stainless Steel
----------	-----------------

K	Cast Iron
----------	-----------

N	Aluminium
----------	-----------

N	Copper
----------	--------

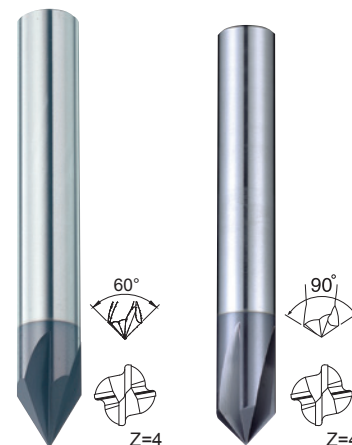
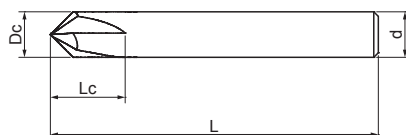

Standard Length

Dc 0 -0.001"	Lc Inch	L Inch	d h6	Bright E108	AlTiN E108X	Bright E109	AlTiN E109X
1/16	3/16	1-1/2	1/8	●	●	●	●
3/32	3/8	1-1/2	1/8	●	●	●	●
1/8	1/2	1-1/2	1/8	●	●	●	●
3/16	5/8	2	3/16	●	●	●	●
1/4	3/4	2-1/2	1/4	●	●	●	●
5/16	13/16	2-1/2	5/16	●	●	●	●
3/8	1	2-1/2	3/8	●	●	●	●
7/16	1	2-3/4	7/16	●	●	●	●
1/2	1	3	1/2	●	●	●	●
5/8	1-1/4	3-1/2	5/8	●	●	●	●
3/4	1-1/2	4	3/4	●	●	●	●

Tolerance: DC

All Sizes: +0/-0.001"

Feature of product:

Application for drilling, chamfering, countersink, spotting, and profile milling.

Double Angle Cutter

4 Flute Chamfering 30°&60°&90°&120°

MG
Carbide

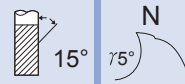
AlTiCrN
HX

Code No: E100HX-30°-DC×L1
 E100HX-60°-DC×L1
 E100HX-90°-DC×L1
 E100HX-120°-DC×L1

Cutter Width(Lc)

Angle Dc	30°	60°	90°	120°
1/16	0.0080	0.0180	0.0310	-
5/64	0.0100	0.0230	0.0390	-
3/32	0.0120	0.0270	0.0470	-
1/8	0.0170	0.0360	0.0620	0.1090
5/32	-	0.0450	0.0780	-
3/16	0.0250	0.0550	0.0930	0.1630
1/4	0.0330	0.0720	0.1250	0.2160
5/16	-	0.0720	0.1250	-
3/8	0.0330	0.0720	0.1250	0.2160
1/2	0.0500	0.1090	0.1870	0.3250

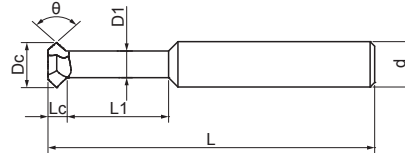

Work Material

P	H	M	K	N	S
●	●	○	○	○	○

P	Steel
----------	-------

H	<52HRC Hardened Steel
----------	--------------------------

M	Stainless Steel
----------	-----------------

K	Cast Iron
----------	-----------

N	Aluminium
----------	-----------

N	Copper
----------	--------

S	Titanium
----------	----------

S	High Temp Alloys
----------	------------------

Tolerance: DC

All Sizes: +0/-0.002"

Feature of product:

Use for high performance applications.

It is extremely heat resistant and used on Steel, Stainless Steels, Cast Iron, Non-ferrous metals and other tough to machine materials.

Standard & Long Length

Dc 0 -0.002"	L Inch	d h6	L1 Inch	D1 Inch	Z Inch	AlTiCrN	AlTiCrN	AlTiCrN	AlTiCrN
						E100HX-30°	E100HX-60°	E100HX-90°	E100HX-120°
1/16	1-1/2	1/8	1/16	1/32	2	○	○	●	○
1/16	1-1/2	1/8	3/32	1/32	2	○	●	●	○
1/16	1-1/2	1/8	1/8	1/32	2	○	○	●	○
1/16	1-1/2	1/8	5/32	1/32	2	○	●	●	○
1/16	1-1/2	1/8	1/4	1/32	2	○	○	●	○
1/16	1-1/2	1/8	3/8	1/32	2	○	○	●	○
5/64	1-1/2	1/8	5/64	0.0390	2	○	○	●	○
5/64	1-1/2	1/8	1/8	0.0390	2	○	●	●	○
5/64	1-1/2	1/8	3/16	0.0390	2	○	○	●	○
5/64	1-1/2	1/8	1/4	0.0390	2	○	○	●	○
5/64	1-1/2	1/8	5/16	0.0390	2	○	○	●	○
5/64	1-1/2	1/8	1/2	0.0390	2	○	○	●	○
3/32	1-1/2	1/8	3/32	3/64	2	○	○	●	○
3/32	1-1/2	1/8	1/8	3/64	2	○	●	●	○
3/32	1-1/2	1/8	1/4	3/64	2	○	○	●	○
3/32	1-1/2	1/8	5/16	3/64	2	○	○	●	○
3/32	1-1/2	1/8	3/8	3/64	2	○	○	●	○
3/32	1-1/2	1/8	1/2	3/64	2	○	○	●	○
3/32	2	1/8	5/8	3/64	2	○	○	●	○
3/32	2	1/8	3/4	3/64	2	○	○	●	○
1/8	1-1/2	1/8	1/8	1/16	4	○	●	●	○
1/8	1-1/2	1/8	3/16	1/16	4	●	●	●	●
1/8	1-1/2	1/8	1/4	1/16	4	○	○	●	○
1/8	1-1/2	1/8	5/16	1/16	4	○	●	●	○
1/8	1-1/2	1/8	3/8	1/16	4	○	○	●	○
1/8	2	1/8	1/2	1/16	4	●	●	●	●
1/8	2	1/8	5/8	1/16	4	○	○	●	○
1/8	2	1/8	3/4	1/16	4	○	○	●	○
1/8	2	1/8	7/8	1/16	4	○	●	●	○
1/8	2	1/8	1	1/16	4	○	○	●	○
5/32	2	3/16	5/32	5/64	4	○	○	●	○
5/32	2	3/16	1/4	5/64	4	○	●	●	○
5/32	2	3/16	3/8	5/64	4	○	○	●	○
5/32	2	3/16	1/2	5/64	4	○	○	●	○
5/32	2-1/2	3/16	5/8	5/64	4	○	●	●	○
5/32	2-1/2	3/16	1-1/8	5/64	4	○	○	●	○

Double Angle Cutter

4 Flute Chamfering 30°&60°&90°&120°

MG
Carbide

AlTiCrN
HX

Code No: E100HX-30°-DC×L1
 E100HX-60°-DC×L1
 E100HX-90°-DC×L1
 E100HX-120°-DC×L1

Standard & Long Length

Dc 0 -0.002"	L Inch	d h6	L1 Inch	D1 Inch	Z Inch	AlTiCrN	AlTiCrN	AlTiCrN	AlTiCrN
						E100HX-30°	E100HX-60°	E100HX-90°	E100HX-120°
3/16	2	3/16	3/16	3/32	4	○	●	●	○
3/16	2	3/16	1/4	3/32	4	○	○	●	○
3/16	2	3/16	5/16	3/32	4	●	●	●	●
3/16	2	3/16	3/8	3/32	4	○	○	●	○
3/16	2	3/16	1/2	3/32	4	○	●	●	○
3/16	2-1/2	3/16	3/4	3/32	4	●	●	●	●
3/16	2-1/2	3/16	1	3/32	4	○	●	●	○
3/16	2-1/2	3/16	1-5/16	3/32	4	○	○	●	○
3/16	3	3/16	1-5/8	3/32	4	○	○	●	○
1/4	2	1/4	3/16	1/8	4	○	●	●	○
1/4	2	1/4	1/4	1/8	4	○	○	●	○
1/4	2	1/4	5/16	1/8	4	●	●	●	●
1/4	2	1/4	3/8	1/8	4	○	○	●	○
1/4	2	1/4	1/2	1/8	4	○	○	●	○
1/4	2-1/2	1/4	5/8	1/8	4	●	●	●	●
1/4	2-1/2	1/4	3/4	1/8	4	○	○	●	○
1/4	3	1/4	1	1/8	4	●	●	●	●
1/4	3	1/4	1-1/4	1/8	4	○	○	●	○
1/4	3	1/4	1-3/8	1/8	4	○	●	●	○
1/4	3	1/4	1-3/4	1/8	4	○	●	●	○
1/4	4	1/4	2-1/8	1/8	4	○	○	●	○
5/16	2-1/2	5/16	1/4	3/16	6	○	○	●	○
5/16	2-1/2	5/16	3/8	3/16	6	○	●	●	○
5/16	2-1/2	5/16	5/8	3/16	6	○	○	●	○
5/16	2-1/2	5/16	7/8	3/16	6	○	●	●	○
5/16	3	5/16	1-1/4	3/16	6	○	○	●	○
5/16	3	5/16	1-5/8	3/16	6	○	○	●	○
5/16	3	5/16	2-1/8	3/16	6	○	○	●	○
3/8	2-1/2	3/8	5/16	1/4	6	○	●	●	○
3/8	2-1/2	3/8	3/8	1/4	6	○	○	●	○
3/8	2-1/2	3/8	1/2	1/4	6	●	●	●	●
3/8	2-1/2	3/8	3/4	1/4	6	○	○	●	○
3/8	2-1/2	3/8	1	1/4	6	●	●	●	●
3/8	3-1/2	3/8	1-1/2	1/4	6	●	●	●	●
3/8	3-1/2	3/8	1-3/4	1/4	6	○	○	●	○
3/8	3-1/2	3/8	2	1/4	6	○	●	●	○
3/8	3-1/2	3/8	2-5/16	1/4	6	○	○	●	○
3/8	4	3/8	2-5/8	1/4	6	○	○	●	○
1/2	3	1/2	5/16	5/16	6	○	○	●	○
1/2	3	1/2	1/2	5/16	6	●	●	●	●
1/2	3	1/2	1	5/16	6	●	●	●	●
1/2	3-1/2	1/2	1-1/4	5/16	6	○	○	●	○
1/2	4	1/2	1-1/2	5/16	6	●	●	●	●
1/2	4	1/2	2	5/16	6	○	●	●	○
1/2	4	1/2	2-5/8	5/16	6	○	●	●	○
1/2	6	1/2	3-1/8	5/16	6	○	○	●	○

※ Mark: ○, On request, no stock

Work Material

P	H	M	K	N	S
●	●	○	○	○	○

P	Steel
----------	-------

H	<52HRC Hardened Steel
----------	--------------------------

M	Stainless Steel
----------	-----------------

K	Cast Iron
----------	-----------

N	Aluminium
----------	-----------

N	Copper
----------	--------

S	Titanium
----------	----------

S	High Temp Alloys
----------	------------------

Tolerance: DC

All Sizes: +0/-0.002"

Feature of product:

Use for high performance applications.

It is extremely heat resistant and used on Steel, Stainless Steels, Cast Iron, Non-ferrous metals and other tough to machine materials.

Drills - Reamers

Page	361	362	362	362	363	365
Apperance						
Code No	D908	D901	D903	D913	D451	D452
Carbide	MG Carbide	MG Carbide	MG Carbide	MG Carbide	MG Carbide	MG Carbide
Coating	Uncoated Bright	Uncoated Bright	Uncoated Bright	Uncoated Bright	Uncoated Bright	Uncoated Bright
Helix Angle					 0°	 15°
No.of Flutes	 2	 2	 2	 2	 2	 2

ANSI

367

369



D453

R391

**MG
Carbide**

**MG
Carbide**

**Uncoated
Bright**

**Uncoated
Bright**



Combined Drills & Countersinks

60° Countersink Angle and Plain Short

MG
Carbide
Uncoated
Bright

Code No: D908-DC

Work Material

P	H	M	K	N	S
●	●	○	●	●	○

P	Steel
----------	-------

H	<48HRC Hardened Steel
----------	--------------------------

M	Stainless Steel
----------	-----------------

K	Cast Iron
----------	-----------

N	Aluminium
----------	-----------

N	Copper
----------	--------

N	Plastics
----------	----------

S	High Temp Alloys
----------	------------------

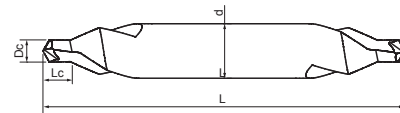

Standard Length

Size No.	Dc h7	Lc h7	L Inch	d h6	Bright D908
#0	1/32	1/32	1-1/4	1/8	●
#1	3/64	3/64	1-1/4	1/8	●
#2	5/64	5/64	1-7/8	3/16	●
#3	7/64	7/64	2	1/4	●
#4	1/8	1/8	2-1/2	5/16	●
#5	3/16	3/16	3	7/16	●
#6	7/32	7/32	3	1/2	●
#7	1/4	1/4	3-1/4	5/8	●
#8	5/16	5/16	3-1/2	3/4	●

Tolerance: DC

All Sizes: h7

Feature of product:

Provide superior wear resistance.
 Can withstand the highest cutting temperatures in low tensile and highly abrasive materials which suitable for Steels, Bronze, Copper, Rubber, Aluminium, Cast Iron, Stainless Steels...etc.

NC Spot Drills

60°&90°&120° Point

MG
Carbide
Uncoated
Bright

Code No: D901-DC-60°
 Code No: D903-DC-90°
 Code No: D913-DC-120°

Work Material

P	H	M	K	N	S
●	●	○	●	●	○

P	Steel
----------	-------

H	<48HRC Hardened Steel
----------	--------------------------

M	Stainless Steel
----------	-----------------

K	Cast Iron
----------	-----------

N	Aluminium
----------	-----------

N	Copper
----------	--------

N	Plastics
----------	----------

S	High Temp Alloys
----------	------------------

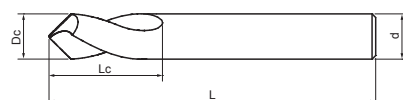

Standard Length

Dc 0 -0.001"	Lc Inch	L Inch	d h6	Bright D901	Bright D903	Bright D913
1/8	5/8	2	1/8	●	●	●
3/16	3/4	2	3/16	●	●	●
1/4	3/4	2-1/2	1/4	●	●	●
5/16	1	2-1/2	5/16	●	●	●
3/8	1	3	3/8	●	●	●
7/16	1	3	7/16	●	●	●
1/2	1-1/4	3	1/2	●	●	●
5/8	1-1/4	3	5/8	●	●	●
3/4	1-3/4	4	3/4	●	●	●
7/8	1-3/4	4	7/8	●	●	●
1	1-3/4	4	1	●	●	●

Tolerance: DC

All Sizes: +0/-0.001"

Feature of product:

Can be used at higher speeds and feeds, compatible with other carbide tools.

Suitable for Steels, Cast Iron, Aluminium, Stainless Steels, Plastics, Bronze and High Temp Alloys.

Straight Flute Drills

140° Point and Straight Flute

**MG
Carbide**
**Uncoated
Bright**

Code No: D451-DC



140°

Work Material

P	H	M	K	N	S
●	●	●	●	●	●

H	<56HRC Hardened Steel
----------	--------------------------

M	Stainless Steel
----------	-----------------

S	High Temp Alloys
----------	------------------

Tolerance: DC

All Sizes: h7

Feature of product:

140° point and straight flute give this drill strength and rigidity.

Recommended for drilling in hard and high strength materials such as Heat treated Steel Alloys, <HRC56, Nickel-chrome Steel, Stainless Steels, Bearing Steels and High Temp Alloys.

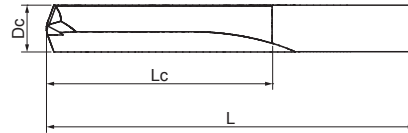

Standard Length

Dc h7	Dec. Equiv. Inch	Lc Inch	L Inch	Bright D451
3/64	0.0469	1/2	1-1/2	●
1/16	0.0625	5/8	1-5/8	●
5/64	0.0781	11/16	1-11/16	●
3/32	0.0938	3/4	1-3/4	●
7/64	0.1094	13/16	1-13/16	●
1/8	0.1250	7/8	1-7/8	●
9/64	0.1406	15/16	2	●
5/32	0.1562	1	2-1/16	●
11/64	0.1719	1-1/16	2-1/8	●
3/16	0.1875	1-1/8	2-3/16	●
13/64	0.2031	1-3/16	2-1/4	●
7/32	0.2188	1-1/4	2-3/8	●
15/64	0.2344	1-5/16	2-7/16	●
1/4	0.2500	1-3/8	2-1/2	●
17/64	0.2656	1-7/16	2-5/8	●
9/32	0.2812	1-1/2	2-11/16	●
19/64	0.2969	1-9/16	2-3/4	●
5/16	0.3125	1-5/8	2-13/16	●
21/64	0.3281	1-11/16	3	●
11/32	0.3438	1-11/16	3	●
23/64	0.3594	1-3/4	3-1/16	●
3/8	0.3750	1-13/16	3-1/8	●
25/64	0.3906	1-7/8	3-1/4	●
13/32	0.4062	1-15/16	3-5/16	●
27/64	0.4219	2	3-3/8	●
7/16	0.4375	2-1/16	3-7/16	●
29/64	0.4531	2-1/8	3-9/16	●
15/32	0.4688	2-1/8	3-5/8	●
31/64	0.4844	2-3/16	3-11/16	●
1/2	0.5000	2-1/4	3-3/4	●
#60	0.0400	1/2	1-1/2	●
#59	0.0410	1/2	1-1/2	●
#58	0.0420	1/2	1-1/2	●
#57	0.0430	1/2	1-1/2	●
#56	0.0465	1/2	1-1/2	●
#55	0.0520	1/2	1-1/2	●
#54	0.0550	1/2	1-1/2	●
#53	0.0595	1/2	1-1/2	●
#52	0.0635	11/16	1-11/16	●
#51	0.0670	11/16	1-11/16	●
#50	0.0700	11/16	1-11/16	●
#49	0.0730	11/16	1-11/16	●
#48	0.0760	11/16	1-11/16	●
#47	0.0785	3/4	1-3/4	●
#46	0.0810	3/4	1-3/4	●
#45	0.0820	3/4	1-3/4	●
#44	0.0860	3/4	1-3/4	●
#43	0.0890	3/4	1-3/4	●
#42	0.0935	3/4	1-3/4	●
#41	0.0960	13/16	1-13/16	●

Straight Flute Drills

140° Point and Straight Flute

MG
Carbide

Uncoated
Bright



Code No: D451-DC

Standard Length

Dc h7	Dec. Equiv. Inch	Lc Inch	L Inch	Bright D451
#40	0.0980	13/16	1-13/16	•
#39	0.0995	13/16	1-13/16	•
#38	0.1015	13/16	1-13/16	•
#37	0.1040	13/16	1-13/16	•
#36	0.1065	13/16	1-13/16	•
#35	0.1100	7/8	1-7/8	•
#34	0.1110	7/8	1-7/8	•
#33	0.1130	7/8	1-7/8	•
#32	0.1160	7/8	1-7/8	•
#31	0.1200	7/8	1-7/8	•
#30	0.1285	15/16	1-15/16	•
#29	0.1360	15/16	1-15/16	•
#28	0.1405	15/16	1-15/16	•
#27	0.1440	1	2-1/16	•
#26	0.1470	1	2-1/16	•
#25	0.1495	1	2-1/16	•
#24	0.1520	1	2-1/16	•
#23	0.1540	1	2-1/16	•
#22	0.1570	1-1/16	2-1/8	•
#21	0.1590	1-1/16	2-1/8	•
#20	0.1610	1-1/16	2-1/8	•
#19	0.1660	1-1/16	2-1/8	•
#18	0.1695	1-1/16	2-1/8	•
#17	0.1730	1-1/8	2-3/16	•
#16	0.1770	1-1/8	2-3/16	•
#15	0.1800	1-1/8	2-3/16	•
#14	0.1820	1-1/8	2-3/16	•
#13	0.1850	1-1/8	2-3/16	•
#12	0.1890	1-3/16	2-1/4	•
#11	0.1910	1-3/16	2-1/4	•
#10	0.1935	1-3/16	2-1/4	•
#9	0.1960	1-3/16	2-1/4	•
#8	0.1990	1-3/16	2-1/4	•
#7	0.2010	1-3/16	2-1/4	•
#6	0.2040	1-1/4	2-3/8	•
#5	0.2055	1-1/4	2-3/8	•
#4	0.2090	1-1/4	2-3/8	•
#3	0.2130	1-1/4	2-3/8	•
#2	0.2210	1-5/16	2-7/16	•
#1	0.2280	1-5/16	2-7/16	•
A	0.2340	1-5/16	2-7/16	•
B	0.2380	1-3/8	2-1/2	•
C	0.2420	1-3/8	2-1/2	•
D	0.2460	1-3/8	2-1/2	•
E	0.2500	1-3/8	2-1/2	•
F	0.2570	1-7/16	2-5/8	•
G	0.2610	1-7/16	2-5/8	•
H	0.2660	1-1/2	2-11/16	•
I	0.2720	1-1/2	2-11/16	•
J	0.2770	1-1/2	2-11/16	•
K	0.2810	1-1/2	2-11/16	•
L	0.2900	1-9/16	2-3/4	•
M	0.2950	1-9/16	2-3/4	•
N	0.3020	1-5/8	2-13/16	•
O	0.3160	1-11/16	2-15/16	•
P	0.3230	1-11/16	2-15/16	•
Q	0.3320	1-11/16	3	•
R	0.3390	1-11/16	3	•
S	0.3480	1-3/4	3-1/16	•
T	0.3580	1-3/4	3-1/16	•
U	0.3680	1-13/16	3-1/8	•
V	0.3770	1-7/8	3-1/4	•
W	0.3860	1-7/8	3-1/4	•
X	0.3970	1-15/16	3-5/16	•
Y	0.4040	1-15/16	3-5/16	•
Z	0.4130	2	3-3/8	•

Work Material

P	H	M	K	N	S
•	•	•	•	•	•

H	<56HRC Hardened Steel
---	--------------------------

M	Stainless Steel
---	-----------------

S	High Temp Alloys
---	------------------

Tolerance: DC

All Sizes: h7

Feature of product:

140° point and straight flute give this drill strength and rigidity. Recommended for drilling in hard and high strength materials such as Heat treated Steel Alloys, <HRC56, Nickel-chrome Steel, Stainless Steels, Bearing Steels and High Temp Alloys.

Slow Spiral Screw Machine Drills

135° Self-Centering Split Point

MG
Carbide
Uncoated
Bright

2

Code No: D452-DC



135°

Work Material

P	H	M	K	N	S
●	●	●	○	●	●

P	Steel
H	<48HRC Hardened Steel
M	Stainless Steel
K	Cast Iron
S	Titanium
S	Nickel

Tolerance: DC

All Sizes: h7

Feature of product:

Provide superior wear resistance.
For use Stainless Steels, Nickel-based and Titanium Alloys, Aluminium, Cast Iron, Bronze and Magnesium.

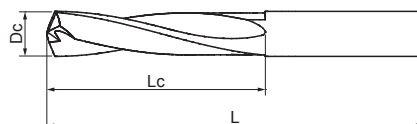

Standard Length

Dc h7	Dec. Equiv. Inch	Lc Inch	L Inch	Bright D452
1/32	0.0312	3/8	1-1/8	●
3/64	0.0469	1/2	1-1/2	●
1/16	0.0625	5/8	1-5/8	●
5/64	0.0781	11/16	1-11/16	●
3/32	0.0938	3/4	1-3/4	●
7/64	0.1094	13/16	1-3/16	●
1/8	0.1250	7/8	1-7/8	●
9/64	0.1406	15/16	1-15/16	●
5/32	0.1562	1	2-1/16	●
11/64	0.1719	1-1/16	2-1/8	●
3/16	0.1875	1-1/8	2-3/16	●
13/64	0.2031	1-3/16	2-1/4	●
7/32	0.2188	1-1/4	2-3/8	●
15/64	0.2344	1-5/16	2-7/16	●
1/4	0.2500	1-3/8	2-1/2	●
17/64	0.2656	1-7/16	2-5/8	●
9/32	0.2812	1-1/2	2-11/16	●
19/64	0.2969	1-9/16	2-3/4	●
5/16	0.3125	1-5/8	2-13/16	●
21/64	0.3281	1-11/16	2-15/16	●
11/32	0.3438	1-11/16	2-15/16	●
23/64	0.3594	1-3/4	3-1/16	●
3/8	0.3750	1-13/16	3-1/8	●
25/64	0.3906	1-7/8	3-1/4	●
13/32	0.4063	1-15/16	3-5/16	●
27/64	0.4219	2	3-3/8	●
7/16	0.4375	2-1/16	3-7/16	●
29/64	0.4531	2-1/8	3-9/16	●
15/32	0.4688	2-1/8	3-5/8	●
31/64	0.4844	2-3/16	3-11/16	●
1/2	0.5000	2-1/4	3-3/4	●
17/32	0.5312	2-3/8	3-7/8	●
9/16	0.5625	2-1/2	4	●
5/8	0.6250	2-3/4	4-1/4	●
3/4	0.7500	3-1/8	5	●
#53	0.0595	1/2	1-1/2	●
#52	0.0635	11/16	1-11/16	●
#51	0.0670	11/16	1-11/16	●
#50	0.0700	11/16	1-11/16	●
#49	0.0730	11/16	1-11/16	●
#48	0.0760	11/16	1-11/16	●
#47	0.0785	3/4	1-3/4	●
#46	0.0810	3/4	1-3/4	●
#45	0.0820	3/4	1-3/4	●
#44	0.0860	3/4	1-3/4	●
#43	0.0890	3/4	1-3/4	●
#42	0.0935	3/4	1-3/4	●
#41	0.0960	13/16	1-13/16	●
#40	0.0980	13/16	1-13/16	●
#39	0.0995	13/16	1-13/16	●

Slow Spiral Screw Machine Drills

135° Self-Centering Split Point

MG Carbide	Uncoated Bright	 15°	 2	 135°
----------------------	----------------------------------	--	--	---

Code No: D452-DC

Standard Length

Dc h7	Dec. Equiv. Inch	Lc Inch	L Inch	Bright D452
#38	0.1015	13/16	1-13/16	●
#37	0.1040	13/16	1-13/16	●
#36	0.1065	13/16	1-13/16	●
#35	0.1100	7/8	1-7/8	●
#34	0.1110	7/8	1-7/8	●
#33	0.1130	7/8	1-7/8	●
#32	0.1160	7/8	1-7/8	●
#31	0.1200	7/8	1-7/8	●
#30	0.1285	15/16	1-15/16	●
#29	0.1360	15/16	1-15/16	●
#28	0.1405	15/16	1-15/16	●
#27	0.1440	1	2-1/16	●
#26	0.1470	1	2-1/16	●
#25	0.1495	1	2-1/16	●
#24	0.1520	1	2-1/16	●
#23	0.1540	1	2-1/16	●
#22	0.1570	1-1/16	2-1/8	●
#21	0.1590	1-1/16	2-1/8	●
#20	0.1610	1-1/16	2-1/8	●
#19	0.1660	1-1/16	2-1/8	●
#18	0.1695	1-1/16	2-1/8	●
#17	0.1730	1-1/8	2-3/16	●
#16	0.1770	1-1/8	2-3/16	●
#15	0.1800	1-1/8	2-3/16	●
#14	0.1820	1-1/8	2-3/16	●
#13	0.1850	1-1/8	2-3/16	●
#12	0.1890	1-3/16	2-1/4	●
#11	0.1910	1-3/16	2-1/4	●
#10	0.1935	1-3/16	2-1/4	●
#9	0.1960	1-3/16	2-1/4	●
#8	0.1990	1-3/16	2-1/4	●
#7	0.2010	1-3/16	2-1/4	●
#6	0.2040	1-1/4	2-3/8	●
#5	0.2055	1-1/4	2-3/8	●
#4	0.2090	1-1/4	2-3/8	●
#3	0.2130	1-1/4	2-3/8	●
#2	0.2210	1-5/16	2-7/16	●
#1	0.2280	1-5/16	2-7/16	●
A	0.2340	1-5/16	2-7/16	●
B	0.2380	1-3/8	2-1/2	●
C	0.2420	1-3/8	2-1/2	●
D	0.2460	1-3/8	2-1/2	●
E	0.2500	1-3/8	2-1/2	●
F	0.2570	1-7/8	2-5/8	●
G	0.2610	1-7/8	2-5/8	●
H	0.2660	1-1/2	2-11/16	●
I	0.2720	1-1/2	2-11/16	●
J	0.2770	1-1/2	2-11/16	●
K	0.2810	1-1/2	2-11/16	●
L	0.2900	1-9/16	2-3/4	●
M	0.2950	1-9/16	2-3/4	●
N	0.3020	1-5/8	2-13/16	●
O	0.3160	1-11/16	2-15/16	●
P	0.3230	1-11/16	2-15/16	●
Q	0.3320	1-11/16	3	●
R	0.3390	1-11/16	3	●
S	0.3480	1-3/4	3-1/16	●
T	0.3580	1-3/4	3-1/16	●
U	0.3680	1-13/16	3-1/8	●
V	0.3770	1-7/8	3-1/4	●
W	0.3860	1-7/8	3-1/4	●
X	0.3970	1-15/16	3-5/16	●
Y	0.4040	1-15/16	3-5/16	●
Z	0.4130	2	3-3/8	●

Work Material

P	H	M	K	N	S
●	●	●	○	●	●

P	Steel
----------	-------

H	<48HRC Hardened Steel
----------	--------------------------

M	Stainless Steel
----------	-----------------

K	Cast Iron
----------	-----------

S	Titanium
----------	----------

S	Nickel
----------	--------

Tolerance: DC

All Sizes: h7

Feature of product:

Provide superior wear resistance.
For use Stainless Steels, Nickel-based and Titanium Alloys, Aluminium, Cast Iron, Bronze and Magnesium.

Jobber Drills

118° Point for Quick Penetration

MG
 Carbide

Uncoated
Bright

Code No: D453-DC

Work Material

P	H	M	K	N	S
○			●	●	

P	Steel
K	Cast Iron
N	Aluminium
N	Copper
N	Plastics
N	FRP CFRP Composite Material

Tolerance: DC

All Sizes: h7

Feature of product:

Provide superior wear resistance.
 Use in lower tensile strength materials such as Cast Iron, Cast Aluminium, Bronze, Copper, Zinc, Brass, Rubber and Plastics, Composite...etc. Also can be applied for drilling with Steel as work material.

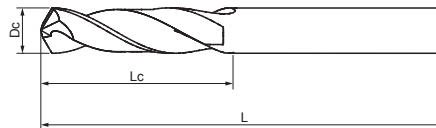

Standard Length

Dc h7	Dec. Equiv. Inch	Lc Inch	L Inch	Bright D453
1/64	0.0156	3/16	3/4	●
1/32	0.0312	5/16	1-1/4	●
3/64	0.0469	3/4	1-1/2	●
1/16	0.0625	3/4	1-1/2	●
5/64	0.0781	7/8	1-3/4	●
3/32	0.0938	1	2	●
7/64	0.1094	1-1/4	2-1/4	●
1/8	0.1250	1-1/4	2-1/4	●
9/64	0.1406	1-3/8	2-1/2	●
5/32	0.1562	1-3/8	2-1/2	●
11/64	0.1719	1-5/8	2-3/4	●
3/16	0.1875	1-5/8	2-3/4	●
13/64	0.2031	1-3/4	3	●
7/32	0.2188	1-3/4	3	●
15/64	0.2344	2	3-1/4	●
1/4	0.2500	2	3-1/4	●
17/64	0.2656	2-1/8	3-1/2	●
9/32	0.2812	2-1/8	3-1/2	●
19/64	0.2969	2-3/8	3-3/4	●
5/16	0.3125	2-3/8	3-3/4	●
21/64	0.3281	2-1/2	4	●
11/32	0.3438	2-1/2	4	●
23/64	0.3594	2-1/2	4-1/4	●
3/8	0.3750	2-3/4	4-1/4	●
25/64	0.3906	2-7/8	4-1/2	●
13/32	0.4062	2-7/8	4-1/2	●
27/64	0.4219	2-7/8	4-1/2	●
7/16	0.4375	2-7/8	4-1/2	●
29/64	0.4531	3	4-3/4	●
15/32	0.4688	3	4-3/4	●
31/64	0.4844	3	4-3/4	●
1/2	0.5000	3	4-3/4	●
17/32	0.5312	3-1/4	5	●
9/16	0.5625	3-1/4	5	●
5/8	0.6250	3-1/2	5-1/4	●
3/4	0.7500	3-7/8	5-3/4	●
#80	0.0135	3/16	3/4	●
#79	0.0145	3/16	3/4	●

Jobber Drills

118° Point for Quick Penetration

**MG
Carbide**
**Uncoated
Bright**

Code No: D453-DC

Standard Length

Dc h7	Dec. Equiv. Inch	Lc Inch	L Inch	Bright D453	Dc h7	Dec. Equiv. Inch	Lc Inch	L Inch	Bright D453
#78	0.0160	3/16	3/4	●	#26	0.1470	1-3/8	2-1/2	●
#77	0.0180	3/16	3/4	●	#25	0.1495	1-3/8	2-1/2	●
#76	0.0200	1/4	7/8	●	#24	0.1520	1-3/8	2-1/2	●
#75	0.0210	1/4	7/8	●	#23	0.1540	1-3/8	2-1/2	●
#74	0.0225	1/4	7/8	●	#22	0.1570	1-3/8	2-1/2	●
#73	0.0240	1/4	7/8	●	#21	0.1590	1-3/8	2-1/2	●
#72	0.0250	5/16	1	●	#20	0.1610	1-3/8	2-1/2	●
#71	0.0260	5/16	1	●	#19	0.1660	1-5/8	2-3/4	●
#70	0.0280	5/16	1	●	#18	0.1695	1-5/8	2-3/4	●
#69	0.0292	5/16	1	●	#17	0.1730	1-5/8	2-3/4	●
#68	0.0310	3/8	1-1/8	●	#16	0.1770	1-5/8	2-3/4	●
#67	0.0320	3/8	1-1/8	●	#15	0.1800	1-5/8	2-3/4	●
#66	0.0330	3/8	1-1/8	●	#14	0.1820	1-5/8	2-3/4	●
#65	0.0350	3/8	1-1/8	●	#13	0.1850	1-5/8	2-3/4	●
#64	0.0360	5/8	1-1/4	●	#12	0.1890	1-5/8	2-3/4	●
#63	0.0370	5/8	1-1/4	●	#11	0.1910	1-5/8	2-3/4	●
#62	0.0380	1/2	1-1/4	●	#10	0.1935	1-5/8	2-3/4	●
#61	0.0390	1/2	1-1/4	●	#9	0.1960	1-3/4	3	●
#60	0.0400	3/4	1-1/2	●	#8	0.1990	1-3/4	3	●
#59	0.0410	3/4	1-1/2	●	#7	0.2010	1-3/4	3	●
#58	0.0420	3/4	1-1/2	●	#6	0.2040	1-3/4	3	●
#57	0.0430	3/4	1-1/2	●	#5	0.2055	1-3/4	3	●
#56	0.0465	3/4	1-1/2	●	#4	0.2090	1-3/4	3	●
#55	0.0520	3/4	1-1/2	●	#3	0.2130	1-3/4	3	●
#54	0.0550	3/4	1-1/2	●	#2	0.2210	1-3/4	3	●
#53	0.0595	3/4	1-1/2	●	#1	0.2280	1-3/4	3	●
#52	0.0635	3/4	1-1/2	●	A	0.2340	2	3-1/4	●
#51	0.0670	3/4	1-1/2	●	B	0.2380	2	3-1/4	●
#50	0.0700	7/8	1-3/4	●	C	0.2420	2	3-1/4	●
#49	0.0730	7/8	1-3/4	●	D	0.2460	2	3-1/4	●
#48	0.0760	7/8	1-3/4	●	E	0.2500	2	3-1/4	●
#47	0.0785	7/8	1-3/4	●	F	0.2570	2	3-1/4	●
#46	0.0810	7/8	1-3/4	●	G	0.2610	2-1/8	3-1/2	●
#45	0.0820	7/8	1-3/4	●	H	0.2660	2-1/8	3-1/2	●
#44	0.0860	1	2	●	I	0.2720	2-1/8	3-1/2	●
#43	0.0890	1	2	●	J	0.2770	2-1/8	3-1/2	●
#42	0.0935	1	2	●	K	0.2810	2-1/8	3-1/2	●
#41	0.0960	1	2	●	L	0.2900	2-1/8	3-1/2	●
#40	0.0980	1	2	●	M	0.2950	2-3/8	3-3/4	●
#39	0.0995	1-1/4	2-1/4	●	N	0.3020	2-3/8	3-3/4	●
#38	0.1015	1-1/4	2-1/4	●	O	0.3160	2-3/8	3-3/4	●
#37	0.1040	1-1/4	2-1/4	●	P	0.3230	2-3/8	3-3/4	●
#36	0.1065	1-1/4	2-1/4	●	Q	0.3320	2-1/2	4	●
#35	0.1100	1-1/4	2-1/4	●	R	0.3390	2-1/2	4	●
#34	0.1110	1-1/4	2-1/4	●	S	0.3480	2-1/2	4	●
#33	0.1130	1-1/4	2-1/4	●	T	0.3580	2-1/2	4-1/4	●
#32	0.1160	1-1/4	2-1/4	●	U	0.3680	2-3/4	4-1/4	●
#31	0.1200	1-1/4	2-1/4	●	V	0.3770	2-3/4	4-1/4	●
#30	0.1285	1-1/4	2-1/4	●	W	0.3860	2-7/8	4-1/2	●
#29	0.1360	1-3/8	2-1/2	●	X	0.3970	2-7/8	4-1/2	●
#28	0.1405	1-3/8	2-1/2	●	Y	0.4040	2-7/8	4-1/2	●
#27	0.1440	1-3/8	2-1/2	●	Z	0.4130	2-7/8	4-1/2	●

Work Material

P	H	M	K	N	S
○			●	●	

P	Steel
---	-------

K	Cast Iron
---	-----------

N	Aluminium
---	-----------

N	Copper
---	--------

N	Plastics
---	----------

N	FRP CFRP Composite Material
---	--------------------------------

Tolerance: DC

All Sizes: h7

Feature of product:

Provide superior wear resistance.

Use in lower tensile strength materials such as Cast Iron, Cast Aluminium, Bronze, Copper, Zinc, Brass, Rubber and Plastics, Composite...etc. Also can be applied for drilling with Steel as work material.

NC Machine Reamers

4&6 Flute Straight Shank Chucking Reamers

MG
 Carbide

 Uncoated
 Bright

Code No: R391-DC

Work Material

P	H	M	K	N	S
○	●	●	●	●	●

P	Steel
----------	-------

H	<48HRC Hardened Steel
----------	--------------------------

K	Cast Iron
----------	-----------

N	Aluminium
----------	-----------

N	Copper
----------	--------

N	Plastics
----------	----------

Tolerance: DC

+0.0001/+0.0002: ≤1/4"(.2500)
 +0.0001/+0.0003: >1/4"(.2500)

Feature of product:

Provide superior wear resistance.
 Can withstand the highest cutting temperatures in low tensile and highly abrasive materials such as Bronze, Copper, Rubber, Aluminium, Cast Iron, and Steel...etc.

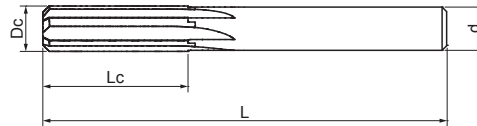

Standard Length

Dc H7	Dec.Equiv. Inch	Lc Inch	L Inch	d Inch	Z teeth	Bright R391
1/32	0.0313	1/4	1-1/2	0.0260	4	●
3/64	0.0469	3/8	1-1/2	0.0410	4	●
1/16	0.0625	3/8	1-1/2	0.0520	4	●
5/64	0.0781	1/2	1-3/4	0.0625	4	●
3/32	0.0938	1/2	2	0.0781	4	●
7/64	0.1094	5/8	2-1/4	0.0938	4	●
1/8	0.1250	5/8	2-1/4	0.1094	4	●
9/64	0.1406	3/4	2-1/2	0.1250	4	●
5/32	0.1562	3/4	2-1/2	0.1406	4	●
11/64	0.1719	7/8	2-3/4	0.1562	4	●
3/16	0.1875	7/8	2-3/4	0.1719	4	●
13/64	0.2031	1	3	0.1875	4	●
7/32	0.2188	1	3	0.1875	4	●
15/64	0.2344	1	3	0.2188	4	●
1/4	0.2500	1	3	0.2188	4	●
17/64	0.2656	1-1/8	3-1/4	0.2500	6	●
9/32	0.2812	1-1/8	3-1/4	0.2500	6	●
19/64	0.2969	1-1/8	3-1/4	0.2812	6	●
5/16	0.3125	1-1/8	3-1/4	0.2812	6	●
21/64	0.3281	1-1/4	3-1/2	0.3125	6	●
11/32	0.3438	1-1/4	3-1/2	0.3125	6	●
23/64	0.3594	1-1/4	3-1/2	0.3125	6	●
3/8	0.3750	1-1/4	3-1/2	0.3594	6	●
25/64	0.3906	1-1/4	3-1/2	0.3750	6	●
13/32	0.4062	1-1/4	3-1/2	0.3750	6	●
27/64	0.4219	1-3/8	4	0.3750	6	●
7/16	0.4375	1-3/8	4	0.3750	6	●
29/64	0.4531	1-3/8	4	0.4375	6	●
15/32	0.4688	1-3/8	4	0.4375	6	●
31/64	0.4844	1-1/2	4	0.4375	6	●
1/2	0.5000	1-1/2	4	0.4375	6	●
#60	0.0400	1/4	1-1/2	0.0360	4	●
#59	0.0410	1/4	1-1/2	0.0360	4	●
#58	0.0420	3/8	1-1/2	0.0380	4	●
#57	0.0430	3/8	1-1/2	0.0380	4	●
#56	0.0465	3/8	1-1/2	0.0410	4	●
#55	0.0520	3/8	1-1/2	0.0410	4	●
#54	0.0550	3/8	1-1/2	0.0520	4	●
#53	0.0595	3/8	1-1/2	0.0520	4	●
#52	0.0635	3/8	1-1/2	0.0520	4	●
#51	0.0670	1/2	1-3/4	0.0625	4	●
#50	0.0700	1/2	1-3/4	0.0625	4	●
#49	0.0730	1/2	1-3/4	0.0625	4	●
#48	0.0760	1/2	1-3/4	0.0625	4	●
#47	0.0785	1/2	1-3/4	0.0625	4	●
#46	0.0810	1/2	1-3/4	0.0625	4	●
#45	0.0820	1/2	2	0.0781	4	●
#44	0.0860	1/2	2	0.0781	4	●
#43	0.0890	1/2	2	0.0781	4	●
#42	0.0935	1/2	2	0.0781	4	●

NC Machine Reamers

4&6 Flute Straight Shank Chucking Reamers

MG
Carbide

Uncoated
Bright



Code No: R391-DC

Standard Length

Dc H7	Dec.Equiv. Inch	Lc Inch	L Inch	d Inch	Z teeth	Bright R391
#41	0.0960	1/2	2	0.0781	4	●
#40	0.0980	5/8	2-1/4	0.0938	4	●
#39	0.0995	5/8	2-1/4	0.0938	4	●
#38	0.1015	5/8	2-1/4	0.0938	4	●
#37	0.1040	5/8	2-1/4	0.0938	4	●
#36	0.1065	5/8	2-1/4	0.0938	4	●
#35	0.1100	5/8	2-1/4	0.0938	4	●
#34	0.1110	5/8	2-1/4	0.0938	4	●
#33	0.1130	5/8	2-1/4	0.0938	4	●
#32	0.1160	5/8	2-1/4	0.1094	4	●
#31	0.1200	5/8	2-1/4	0.1094	4	●
#30	0.1285	5/8	2-1/4	0.1094	4	●
#29	0.1360	3/4	2-1/2	0.1250	4	●
#28	0.1405	3/4	2-1/2	0.1250	4	●
#27	0.1440	3/4	2-1/2	0.1250	4	●
#26	0.1470	3/4	2-1/2	0.1406	4	●
#25	0.1495	3/4	2-1/2	0.1406	4	●
#24	0.1520	3/4	2-1/2	0.1406	4	●
#23	0.1540	3/4	2-1/2	0.1406	4	●
#22	0.1570	3/4	2-1/2	0.1406	4	●
#21	0.1590	3/4	2-1/2	0.1406	4	●
#20	0.1610	7/8	2-3/4	0.1562	4	●
#19	0.1660	7/8	2-3/4	0.1562	4	●
#18	0.1695	7/8	2-3/4	0.1562	4	●
#17	0.1730	7/8	2-3/4	0.1562	4	●
#16	0.1770	7/8	2-3/4	0.1719	4	●
#15	0.1800	7/8	2-3/4	0.1719	4	●
#14	0.1820	7/8	2-3/4	0.1719	4	●
#13	0.1850	7/8	2-3/4	0.1719	4	●
#12	0.1890	7/8	2-3/4	0.1719	4	●
#11	0.1910	7/8	2-3/4	0.1719	4	●
#10	0.1935	1	3	0.1875	4	●
#9	0.1960	1	3	0.1875	4	●
#8	0.1990	1	3	0.1875	4	●
#7	0.2010	1	3	0.1875	4	●
#6	0.2040	1	3	0.1875	4	●
#5	0.2055	1	3	0.1875	4	●
#4	0.2090	1	3	0.1875	4	●
#3	0.2130	1	3	0.1875	4	●
#2	0.2210	1	3	0.1875	4	●
#1	0.2280	1	3	0.2188	4	●
A	0.2340	1	3	0.2188	4	●
B	0.2380	1	3	0.2188	4	●
C	0.2420	1	3	0.2188	4	●
D	0.2460	1	3	0.2188	4	●
E	0.2500	1	3	0.2188	4	●
F	0.2570	1-1/8	3-1/4	0.2500	6	●
G	0.2610	1-1/8	3-1/4	0.2500	6	●
H	0.2660	1-1/8	3-1/4	0.2500	6	●
I	0.2720	1-1/8	3-1/4	0.2500	6	●
J	0.2770	1-1/8	3-1/4	0.2500	6	●
K	0.2810	1-1/8	3-1/4	0.2500	6	●
L	0.2900	1-1/8	3-1/4	0.2812	6	●
M	0.2950	1-1/8	3-1/4	0.2812	6	●
N	0.3020	1-1/8	3-1/4	0.2812	6	●
O	0.3160	1-1/8	3-1/4	0.2812	6	●
P	0.3230	1-1/4	3-1/2	0.3125	6	●
Q	0.3320	1-1/4	3-1/2	0.3125	6	●
R	0.3390	1-1/4	3-1/2	0.3125	6	●
S	0.3480	1-1/4	3-1/2	0.3125	6	●
T	0.3580	1-1/4	3-1/2	0.3125	6	●
U	0.3680	1-1/4	3-1/2	0.3594	6	●
V	0.3770	1-1/4	3-1/2	0.3594	6	●
W	0.3860	1-1/4	3-1/2	0.3594	6	●
X	0.3970	1-1/4	3-1/2	0.3750	6	●
Y	0.4040	1-1/4	3-1/2	0.3750	6	●
Z	0.4130	1-1/4	3-1/2	0.3750	6	●

Work Material

P	H	M	K	N	S
○	●	■	●	●	■

P Steel

H <48HRC
Hardened Steel

K Cast Iron

N Aluminium

N Copper

N Plastics

Tolerance: DC

+0.0001/+0.0002: ≤1/4"(.2500)
+0.0001/+0.0003: >1/4"(.2500)

Feature of product:

Provide superior wear resistance.
Can withstand the highest cutting temperatures in low tensile and highly abrasive materials such as Bronze, Copper, Rubber, Aluminium, Cast Iron, and Steel...etc.

Interchangeable Multi-purpose End Mill Cutter

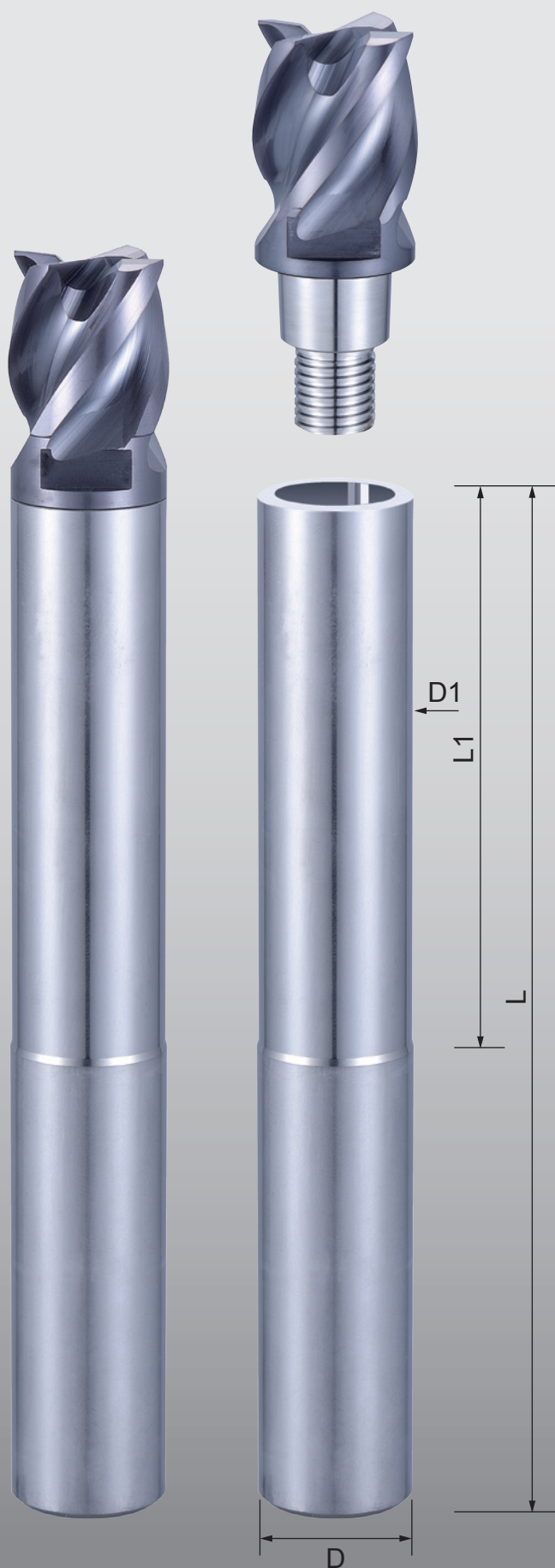

1. Double-contact surface (taper and face)
2. Solid carbide cutter head and body shank
3. High accuracy, rigidity and efficiency in cutting
4. High economy value with various interchangeable cutter heads
5. Trapezoidal-designed thread reduces thread chipping
6. Runout within 5µm

Code No.	D h6	L inch	L1 inch	D1 inch	Price
EMH127U127079019	1/2	0.5	3-1/8	3/4	0.48 ●
EMH127U127101038	1/2	0.5	4	1-1/2	0.48 ●
EMH127S127101000	1/2	0.5	4	-	- ●
EMH159U159089023	5/8	0.625	3-1/2	15/16	0.605 ●
EMH159U159127047	5/8	0.625	5	1-7/8	0.605 ●
EMH159S159127000	5/8	0.625	5	-	- ●
EMH190U190101028	3/4	0.75	4	1-1/8	0.730 ●
EMH190U190152057	3/4	0.75	6	2-1/4	0.730 ●
EMH190S190152000	3/4	0.75	6	-	- ●
EMH254U254127038	1	1	5	1-1/2	0.980 ●
EMH254U254178076	1	1	7	3	0.980 ●
EMH254S254178000	1	1	7	-	- ●

Interchangeable Multi-purpose End Mill Cutter

E140HX-Cutter

Code No.	Dc 0 -0.001		Lc inch	L1 inch	D1 inch	AlTiCrN HX
EMH127-SM127	1/2	0.5	1/2	3/4	0.48	●
EMH159-SM159	5/8	0.625	5/8	15/16	0.605	●
EMH190-SM190	3/4	0.75	3/4	1-1/8	0.73	●
EMH254-SM254	1	1	1	1-1/2	0.98	●

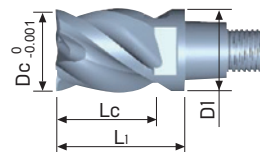

E143-Cutter

Code No.	Dc 0 -0.001		Lc inch	L1 inch	D1 inch	Bright
EMH127-SA127	1/2	0.5	1/2	3/4	0.48	●
EMH159-SA159	5/8	0.625	5/8	15/16	0.605	●
EMH190-SA190	3/4	0.75	3/4	1-1/8	0.73	●
EMH254-SA254	1	1	1	1-1/2	0.98	●



E166TX-Cutter

Code No.	Dc 0 -0.001		Lc inch	L1 inch	D1 inch	No. of Flute	AlTiSiN TX
EMH127-EF127	1/2	0.5	1/2	3/4	0.48	6	●
EMH159-EF159	5/8	0.625	5/8	15/16	0.605	6	●
EMH190-EF190	3/4	0.75	3/4	1-1/8	0.73	8	●
EMH254-EF254	1	1	1	1-1/2	0.98	10	●



B254TX-Cutter

Code No.	Dc 0 -0.001		Lc inch	L1 inch	D1 inch	AlTiSiN TX
EMH127-BH127	1/2	0.5	1/2	3/4	0.48	●
EMH159-BH159	5/8	0.625	5/8	15/16	0.605	●
EMH190-BH190	3/4	0.75	3/4	1-1/8	0.73	●
EMH254-BH254	1	1	1	1-1/2	0.98	●



Interchangeable Blank Cutter Heads

Code No. EMH127-12733 / EMH159-15941 / EMH190-19050 / EMH254-25465

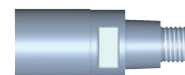

Technical Data - Materials

Materials Groups		N/mm2	HB	JIS	DIN
P	GR.1 Non-alloyed Steel	≤700	≤210	SS330 SS400 SS490 S10C S15C S20C S25C S30C S35C S40C S45C S50C S55C S58C SUM22 SUM22L SUM24 SUM25 SK3 SUP4	RST37-1 St37-3 St37-2 9SMn28 9SMnPb28 9SMnPb36 Ck15 Ck25 CK30 Ck45 Cf53C10 C15 C20 C22C35 C45 C55 C60 Ck55 Ck60 C105W1 C105W1
	GR.2 <24HRC Low-alloyed Steel	700-1000	210-300	SCR415 SCR420 SCR430 SCR440 SCR445 SCM420 SCM415 SCM430 SCM440 SK1 SK2 SK3 SK5 SK6 SK7	St.44-2 St.52-3 100Cr6 2INiCrMo2 40NiCrMo22 17CrNiMo6 15Cr3 42Cr3 55Cr3 15CrMo5 36NiCr6 14NiCr10 34Cr4 41Cr4 16MnCr5 25CrMo4 34CrMo4 41CrMo4 42CrMo4 32CrMo12 50CrV4 41CrAlMo7 100Cr6 105WCr6
	GR.3 <30HRC Hi-alloyed Steel	>1000	>300	SKD1 SKD2 SKD3 SKD4 SKD11 SKD12 SKD61 P20 P21 P30 SUP3 SUP4 SUP6 SUP3 SUP6 SUP7 SUP9 SUP10 SKH2 SKH3 SKH52 SKH55	X210Cr12 X40CrMoV5 1 X100CrMoV5 1 X210CrW12 45WCrV7 X30WCrV9 3 X30WCrV9 3KU X165CrMoV12 X45GrSi93 S6-5-2 S6/5/2 S6/5/2/5 S2/9/2 X210Cr12 G
H	GR.4 30~38HRC Hardened Steel				
	GR.5 38~48HRC Hardened Steel				
	GR.6 48~56HRC Hardened Steel				
	GR.7 56~68HRC Hardened Steel				
M	GR.8 Stainless Steel	500~ 950	250~320	SUS301 SUS302 SUS303 SUS304 SUS316 SUS321 SUS410 SUS416 SUS420 SUS420J2 SUS430 SUS431 SUS440	X12CrNi17-7 X12CrNi18-8 X10CrNiSi18-9 X5CrNi18-10 X5CrMo17-12-2 X6CrNiTi18-10 X10Cr13 X12CrSi3 X30Cr13 X12CrMoSi7 X20CrNi17-2 X65CrMo14
K	GR.9 Cast Iron		180-280	FC100 FC150 FC200 FC250 FC300 FC350 FCD400 FCD500 FCD600 FCD700 FCMB310 FCMW330 FCMW370 FCMP490 FCMP540 FCMP590 FCMP690	GG10 GG15 GG20 GG25 GG30 GG35 GGG40 GGG50 GGG60 GGG70 GTS-35 GTS-45 GTS-55 GTS-65 GTS65-02 GTS-70-02
N	GR.10 Aluminium		Si<10%	A1050 A1080 A2014 A3003 A5052 A6061 A7075 MPI	A199 ,5 A199.8 AlMnCu AlCuSiMn AiMgSiCu AlZnMgCu4.5 MgAl3Zn G-AlSi5Mg
			Si10%>	A1050 A1080 A2014 A3003 A5052 A6061 A7075 MPI	GD-AISi12 GD-AISi10Mg G-AISi10Mg AISi17C4 AISi21CuNiMg AISi25CuNiMg
	GR.11 Copper		<250	C1220P C3710P C2400P C5210P C3602BE C3601BE C3604BE C3771BE C4622BE C4430P C6711P BC3 BC6	CuZn36Pb3 CuZn39Pb2 CuZn39Pb3 CuZn40Pb2 CuZn28Sn1 CuZn38Si1 CuZn15 CuZn36 CuZn40 ZCuZn10Zn2 CuAl5 CuAl8Fe3 CuAl10Ni5Fe4 CuBe2F40 CuSi3Mn G-CuSn5ZnPb G-CuSn10Zn
			>250	C1700P C1720P C5212P C6782BE	CuBe1.7 F55 CuBe1.7 F110 CuBe2 F70 CuBe2 F125 CuZn40Al1 CuAl11Ni6Fe5 AMPCO 20
	GR.12 Plastics			PP PS POM PC PA PMMA TFE CTFE	
	GR.13 FRP CFRP Composite Material			GFK KFK AFK	
GR.14 Graphite					
S	GR.15 Titanium	700~ 1250	210~370	TP[TR]270H© TP[TR]340H© TP[TR]550H(C) TP[TR]480H© TP[TR]270Pd© TP[TR]340Pd TP[TR]550Pd© TP[TR]480Pd© TAP6400	Ti 1 Ti 2 Ti 3 Ti 4 Ti 1 Pd Ti 2 Pd Ti 3 Pd Ti99.7 Ti99.8 TiAl6V4 TiAl6V4ELI TiAl5Sn2.5 TiAl4Mo4Sn4Si0.5 TiCu2
	GR.16 Nickel	900~ 1200	260~350	Incoloy 800 Incoloy825 I Inconel 400 nconel 625 Inconel 600 Inconel 700 Inconel 713 Inconel 718 Haynes 600 Hastelloy C Nimocast PD36 Nimonic PE13 Nimonic 901 Nimonic 75 Rene 95 ,Monet400, Mar-M432, Waspaloy ,Jessop G64 AirResist213 Jetalloy209	
	GR.17 High Temp Alloys	900- 1400	210-400	SUH309 SUH310 SUH330 SUH1 SUH31 SUH35 SUH321 SUH430 SUH420J1	X15CrNiSi20-12 X15CrNiSi25-20 X45CrSi9-3 X45CrNiW18-9 X53CrMnNi21-9 X10CrNiTi18-9 X6Cr17 X20Cr13

AISI/SAE	BS	GB
1010 1015 1020 1025 1030 1035 1040 1045 1050 1055 1060 W1 W210 1213 12L13 12L14	230M07 080M15 060A35 080M46 060A35 080M46 060A52 070M55 080A62 070M55 080 A 62 060A 96 BW 1A BW2	Q215AF Q235A-D 10 15 20 25 30 35 40 45 50 55 60 Y12 Y15pb
9840 4340 5132 5140 5115 4130 4137, 4135 4140, 4142 4140 L3 L6 ASTM A350LF5 8620 8740 5010 5140 5155 9262 52100	708M40 708M40 722M24 735A50 805M20 311-TYPE7 820A16 523M15 527A60 534 A99 4360 43C 4360 50B	15Cr 20Cr 30Cr 40Cr 45Cr 20CrMo 15CrMo 30CrMo 42CrMo
D3 H13 A2 S1 H21 HW3 D3 M2 M35 M7 HNV3	BD3 BHI3 BA2 BS1 BH21 40IS45 4959BA2 BM2 BM35	Cr12 C12MoV Cr12MoV1 CrMo1v 4Cr5MoSiV1 W18Cr4V W18Cr4V5Co5 W6Mo5Cr4V2Co5 W6MoCr4V3 55CrMnA 85 60Si2Mn 50CrVa
AISI301 AISI302 AISI303 AISI304 AISI316 AISI321 AISI410 AISI416 AISI420 AISI430 AISI431 AISI440	430S15 410S21 420S45 431S29 430S17 304S11 303S21 304C12 321S12 316S16 317S12 403S17	1Cr17Ni7 1Cr18Ni9 Y1Cr18Ni9 0Cr18Ni9 0Cr17Ni12Mo2 0Cr18Ni11Ti 1Cr13 Y1Cr13 3Cr13 1Cr17 7Cr17 2Cr13 Y3Cr13
No20B No25B No30B No35B No45B No50B 60-40-18 80-55-06 A43D2 100-70-03 32510 40010 50005 70003 A220-70003 A220- 80002	Grade150 Grade220 Grade260 Grade300 Grade350 Grade400 SNG420/12 SNG500/7 SNG600/3 SNG700/2 8290/6 B340/12 P440/7 P510/4 P570/3 P690/2	HT-100 HT-150 HT-200 HT-250 HT-300 HT350 QT400-15 QT450-10 QT500-7 QT600-3 QT700-2 KTH-330-08 KTZ-450-06 KTZ-550-04 KTZ-700- 02
2014 3003 5052 6061 7075 AZ31C A296.0 A331.1	LM4 LM12 LM16 LM21 LM22 LM24 LM25 LM27	L1 L3 LD10 LF2 LF21 LD2 LC4 LC9
S12A SC84A SCI02A AA336 A332 B26M520.0	LM5 LM6 LM9 LM13 LM28 LM29 LM30	ZL104 Y104 Y102 ZL102 ZL301
C36000 C37700 C44300 C46200 C83600 C90500 CT-00 10-N 75Cu-5Al 77Cu-15Pb-7Sn-IFe 1C Am CDA544 CDA65600	CA104 CZ121 CZ122 CZ108 CZ114 CDA544 CDA65600 CDA656	ZCuSn5Pb5Zn5 G-CuSn10Z HPb 61-1 HPb 59-1 HSn 62-1
CI7000 CI7200		QBe1.7 QBe2 HA1 60-1-1
AMS R54520 AMS R56400 AMS R56401 Gr.1 Gr.2 Gr.3 Gr.4 Gr.11 Gr.7 Gr.5	TA14/17 TA10-13 TA28 TAl1	TA0 TA1 TA2 TA3 TA9 TC4
AISI309 AISA310 HNV3 EV9 AISI321 AISI430 AISI420	330C11 Hr5.203-4 3146-3 HR8 3072-76 Hr401.601	2Cr23Ni13 2Cr25Ni20 4Cr9Si2 5Cr21Mn9Ni4N 0Cr18Ni11Ti 1Cr17 2Cr13

Table of Cutting Formula

Metric MM	MM	English INCH	INCH
$V_c = \frac{\pi \times D_c \times N}{1000}$		$V_c = \frac{\pi \times D_c \times N}{12}$	
$N = \frac{V_c \times 1000}{\pi \times D_c}$		$N = \frac{V_c \times 12}{\pi \times D_c}$	
$V_f = N \times Z \times f_z$		$V_f = N \times Z \times f_z$	
$T = \frac{L}{V_f}$		$T = \frac{L}{V_f}$	
$V_c =$ Cutting Speed	m/min	$V_c =$ Cutting Speed	inch/min
$D_c =$ Cutter Diameter	mm	$D_c =$ Cutter Diameter	inch
$N =$ RPM	rev/min	$N =$ RPM	rev/min
$V_f =$ Feed Speed	mm/min	$V_f =$ Feed Speed	inch/min
$f_z =$ Feed Per Tooth	mm/tooth	$f_z =$ Feed Per Tooth	inch/tooth
$f_n =$ Feed Per Revolution	mm/rev	$f_n =$ Feed Per Revolution	inch/rev
$Z =$ Number of Flutes	Z	$Z =$ Number of Flutes	Z
$T =$ Time of Cut In Minutes	mm	$T =$ Time of Cut In Minutes	inch
$L =$ Cut Length	mm	$L =$ Cut Length	inch
$A_p =$ Axial depth of cut	mm	$A_p =$ Axial depth of cut	inch
$A_e =$ Radial depth of cut	mm	$A_e =$ Radial depth of cut	inch

Type	Color	Hardness (HV)	Thickness (μm)	Coefficient of Friction	Heat resistance (°C)	Cutting Tools Material	Application
AlTiSiN (TX)	Tan	4300	1~3	0.3	1200	Solid Carbide	Hardened steel
AlTiXN (XI)	Blue black	4000	1~3	0.4	900	Solid Carbide	Carbon steel, Alloyed steel, Hardened steel, Cast iron
AlTiXN+ZrN (SX)	Yellow brown	3800	1~4	0.4	800	Solid Carbide	Carbon steel, Alloyed steel, Stainless steel, Cast iron
AlTiCrN (HX)	Purple black	3800	1~4	0.25	800	Solid Carbide	Carbon steel, Alloyed steel, Stainless steel, Cast iron
ZrN (ZX)	Yellow brown	2800	1~4	0.5	550	Solid Carbide	Aluminium, Copper, Stainless steel, Titanium, Hard-cut material
Diamond (DC)	Black	9000	6~13	0.15	600	Solid Carbide	Graphite
TiN (N)	Golden	2400	1~7	0.35	600	HSS	General steel, Wear parts
TiCN (C)	Blue gray	2800	1~4	0.2	400	HSS	General steel, Wear parts

Usage of each coating for Milling Steel

Cutting Tools Material: Solid Carbide

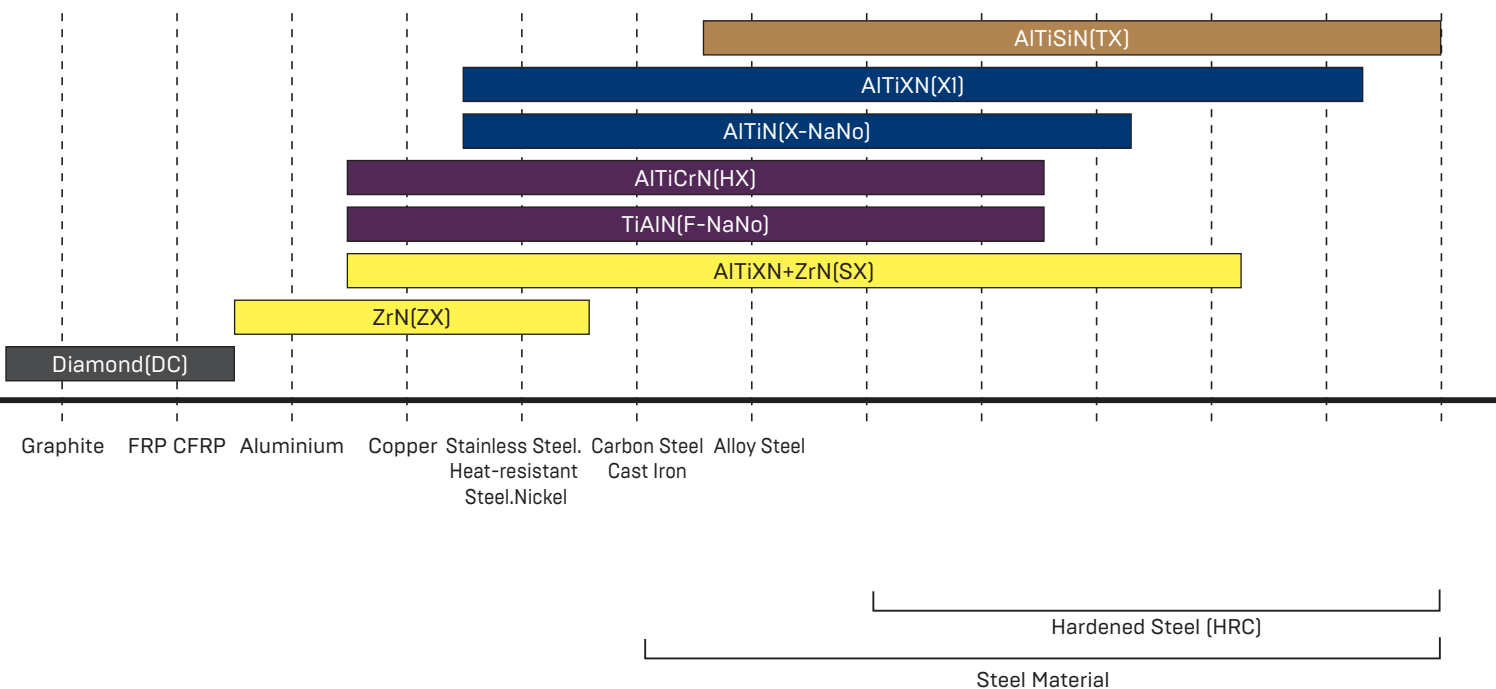

Hardness Conversion Table

HRC	HB	HV10	N/mm ²
	71	75	240
	76	80	255
	81	85	270
	86	90	285
	90	95	305
	95	100	320
	100	105	335
	105	110	350
	109	115	370
	114	120	385
	119	125	400
	124	130	415
	128	135	430
	133	140	450
	138	145	465
	143	150	480
	147	155	495
	152	160	510
	157	165	530
	162	170	545
	166	175	560
	171	180	575
	176	185	595
	181	190	610
	185	195	625
	190	200	640
	195	205	660
	199	210	675
	204	215	690
	209	220	705
	214	225	720
	219	230	740
	223	235	755
	228	240	770
	233	245	785
22	238	250	800
23	242	255	820
24	247	260	835
25	255	268	860
26	258	272	870
27	266	280	900

HRC	HB	HV10	N/mm ²
28	273	287	920
29	278	293	940
30	287	302	970
31	295	310	995
32	301	317	1020
33	311	327	1050
34	319	336	1080
35	328	345	1110
36	337	355	1140
37	346	364	1170
38	354	373	1200
39	363	382	1230
40	372	392	1260
41	383	403	1300
42	393	413	1330
43	402	423	1360
44	413	434	1400
45	424	446	1440
46	435	458	1480
47	449	473	1530
48	460	484	1570
49	472	497	1620
50	488	514	1680
51	501	527	1730
52	517	544	1790
53	532	560	1845
54	549	578	1910
55	567	596	1980
56	584	615	2050
57	607	639	2140
58	622	655	
59		675	
60		698	
61		720	
62		745	
63		773	
64		800	
65		829	
66		864	
67		900	
68		940	

ISO Tolerance measure table [μm]

ϕ mm	<3	3-6	6-10	10-18	18-30	30-50	50-65	65-80
e7	- 14 - 24	- 20 - 32	- 25 - 40	- 32 - 50	- 40 - 61	- 50 - 75	- 60 - 90	- 60 - 90
e8	- 14 - 28	- 20 - 38	- 25 - 47	- 32 - 59	- 40 - 73	- 50 - 89	- 60 - 106	- 60 - 106
e9	- 14 - 39	- 20 - 50	- 25 - 61	- 32 - 75	- 40 - 92	- 50 - 112	- 60 - 134	- 60 - 134
h5	0 - 4	0 - 5	0 - 6	0 - 8	0 - 9	0 - 11	0 - 13	0 - 13
h6	0 - 6	0 - 8	0 - 9	0 - 11	0 - 13	0 - 16	0 - 19	0 - 19
h7	0 - 10	0 - 12	0 - 15	0 - 18	0 - 21	0 - 25	0 - 30	0 - 30
h8	0 - 14	0 - 18	0 - 22	0 - 27	0 - 33	0 - 39	0 - 46	0 - 46
h9	0 - 25	0 - 30	0 - 36	0 - 43	0 - 52	0 - 62	0 - 74	0 - 74
h10	0 - 40	0 - 48	0 - 58	0 - 70	0 - 84	0 - 100	0 - 120	0 - 120
h11	0 - 60	0 - 75	0 - 90	0 - 110	0 - 130	0 - 160	0 - 190	0 - 190
h16	0 - 600	0 - 750	0 - 900	0 - 1100	0 - 1300	0 - 1600	0 - 1900	0 - 1900
js14	+ 125 - 125	+ 150 - 150	+ 180 - 180	+ 215 - 215	+ 260 - 260	+ 310 - 310	+ 370 - 370	+ 370 - 370
js16	+ 300 - 300	+ 375 - 375	+ 450 - 450	+ 550 - 550	+ 650 - 650	+ 800 - 800	+ 950 - 950	+ 950 - 950
k11	+ 60 0	+ 75 0	+ 90 0	+ 110 0	+ 130 0	+ 160 0	+ 190 0	+ 190 0
k12	+ 100 0	+ 120 0	+ 150 0	+ 180 0	+ 210 0	+ 250 0	+ 300 0	+ 300 0
m6	+ 8 + 2	+ 12 + 4	+ 15 + 6	+ 18 + 7	+ 21 + 8	+ 25 + 9	+ 30 + 11	+ 30 + 11
m7	+ 12 + 2	+ 16 + 4	+ 21 + 6	+ 25 + 7	+ 29 + 8	+ 34 + 9	+ 41 + 11	+ 41 + 11
z9	+ 51 + 26	+ 65 + 35	+ 78 + 42	+ 103 + 60	+ 140 + 88	+ 198 + 136	+ 246 + 172	+ 284 + 210
H5	+ 4 0	+ 5 0	+ 6 0	+ 8 0	+ 9 0	+ 11 0	+ 13 0	+ 13 0
H6	+ 6 0	+ 8 0	+ 9 0	+ 11 0	+ 13 0	+ 16 0	+ 19 0	+ 19 0
H7	+ 10 0	+ 12 0	+ 15 0	+ 18 0	+ 21 0	+ 25 0	+ 30 0	+ 30 0
H8	+ 14 0	+ 18 0	+ 22 0	+ 27 0	+ 33 0	+ 39 0	+ 46 0	+ 46 0
H9	+ 25 0	+ 30 0	+ 36 0	+ 43 0	+ 52 0	+ 62 0	+ 74 0	+ 74 0
H10	+ 40 0	+ 48 0	+ 58 0	+ 70 0	+ 84 0	+ 100 0	+ 120 0	+ 120 0
H11	+ 60 0	+ 75 0	+ 90 0	+ 110 0	+ 130 0	+ 160 0	+ 190 0	+ 190 0
P6	- 6 - 12	- 9 - 17	- 12 - 21	- 15 - 26	- 18 - 31	- 21 - 37	- 26 - 45	- 26 - 45
P7	- 6 - 16	- 8 - 20	- 9 - 24	- 11 - 29	- 14 - 35	- 17 - 42	- 21 - 51	- 21 - 51
P9	- 6 - 31	- 12 - 42	- 15 - 51	- 18 - 61	- 22 - 74	- 26 - 88	- 32 - 106	- 32 - 106



7-Leaders Corp.

No. 98-110, 1st Rd., Taichung Industrial Park,
Taichung City 40767, Taiwan

TEL:+886-4-2359-7000

FAX:+886-4-2359-7118

E-mail:etm@7Leaders.com

www.7Leaders.com



WEBSITE