

Square End Mills
2&4 Flute Center Cutting

MG Carbide Bright TiAlN 30° 710° 90°

Code No: E182-DC / E184-DC
Code No: E185-DC / E186-DC
Code No: E187-DC / E188-DC

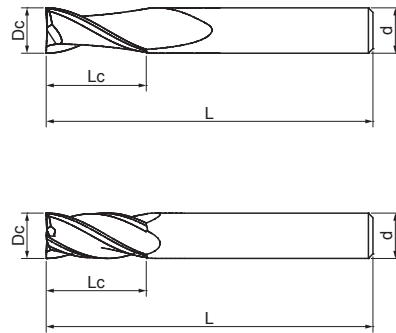

Work Material

P	H	M	K	N	S
●	○	○	○	○	○

P	鋼鐵 Steel
M	不銹鋼 Stainless Steel
K	鑄鐵 Cast Iron
N	鋁 Aluminium
N	銅 Copper
N	塑膠 Plastics
S	鈦合金 Titanium
S	鎳 Nickel

Tolerance: DC
All Sizes: +0/-0.03mm

Feature of product:
中心切削工具可用於各種應用，包括插銑、鑽孔、斜插銑。
TiAlN 具高耐腐蝕性塗層，廣泛應用於航太材料、鎳合金、不銹鋼、鈦合金、鑄鐵、鋼鐵。

Long Length

Dc 0 -0.03	Lc mm	L mm	d h6	Bright E182	TiAlN E182F	Bright E184	TiAlN E184F
3	20	57	3	●	●	●	●
4	20	57	4	●	●	●	●
5	25	63	5	●	●	●	●
6	28	75	6	●	●	●	●
7	30	75	8	●	●	●	●
8	30	75	8	●	●	●	●
9	32	75	10	●	●	●	●
10	32	75	10	●	●	●	●
12	50	100	12	●	●	●	●
14	57	127	14	●	●	●	●
16	57	127	16	●	●	●	●
20	57	127	20	●	●	●	●

Extra Long Length

Dc 0 -0.03	Lc mm	L mm	d h6	Bright E185	TiAlN E185F	Bright E186	TiAlN E186F
3	25	75	3	●	●	●	●
4	28	75	4	●	●	●	●
5	32	75	5	●	●	●	●
6	38	100	6	●	●	●	●
8	42	100	8	●	●	●	●
10	45	100	10	●	●	●	●
12	75	150	12	●	●	●	●
14	80	150	14	●	●	●	●
16	80	150	16	●	●	●	●
20	80	150	20	●	●	●	●

Extra Long Length

Dc 0 -0.03	Lc mm	L mm	d h6	Bright E187	TiAlN E187F	Bright E188	TiAlN E188F
5	45	100	6	●	●	●	●
6	50	100	6	●	●	●	●
8	75	150	8	●	●	●	●
10	75	150	10	●	●	●	●
12	75	200	12	●	●	●	●
16	80	200	16	●	●	●	●
20	80	200	20	●	●	●	●