

**Interchangeable High Performance End Mills With Corner Radius**

Stepped High Performance End Mills with Corner Radius

High precision R value and strong short cutting length.

Suitable for working high hardness materials and high precision mold in layer machining.

Nano multilayer coating, wear resistance and lubrication effect are highly enhanced to have better tool life.

高效分層銑削用R角立銑刀

高精密R值、短刃高強度。

具有良好的刀具壽命。

適用於高硬度材料、高精密模具分層銑削加工。  
搭配奈米多層膜塗層具有優異的潤滑及耐磨性。

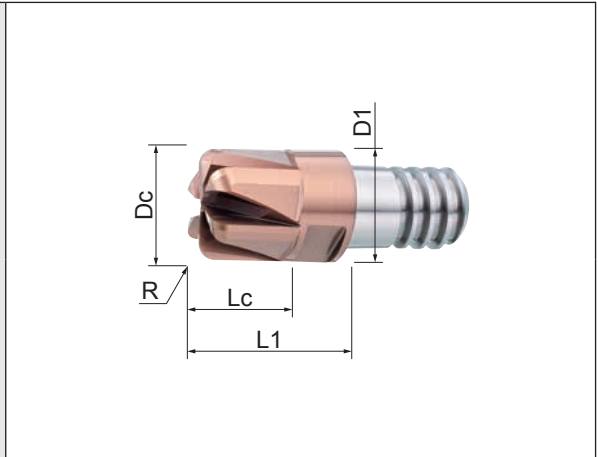

Code No.	Dc 0 -0.03	R ±0.01	Lc mm	L1 mm	D1 mm	Z	AITiSiN TX
IMP10-B271TX100007R20	10	2	7.5	13.5	9.7	4	●
IMP12-B271TX120009R20	12	2	9	16	11.7	4	●
IMP16-B271TX160012R30	16	3	12	20	15.5	6	●
IMP20-B271TX200015R30	20	3	15	25	19.5	6	●

鋼鐵、不銹鋼  
不等分高效率立銑刀

鋼鐵、不銹鋼、難削材  
多用途立銑刀

鋁用立銑刀

鋼鐵、不銹鋼  
圓溝高效率立銑刀

通用、精加工立銑刀

圓頭、R角立銑刀

鑽頭、鉸刀